

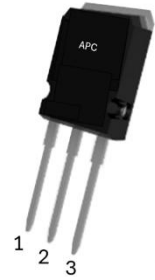

SiC Power MOSFET with Ceramic Isolated Baseplate Tab

AMR030V120E2i

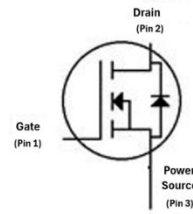

Applications:

- Solar Inverters
- Uninterrupted power supplies
- Switch mode power supplies
- Motor drives

Features:

- High blocking voltage with low on-resistance
- High switching speed with low capacitance
- Very low switching losses
- Excellent avalanche ruggedness
- Very fast and robust intrinsic body diode with low reverse recovery
- 0V turn-off V_{gs} for gate driving ease
- RoHS compliant

Absolute Maximum Ratings ($T_{amb}=25^{\circ}C$, unless specified otherwise)

Symbol	Parameter	Value	Unit
V_{DS}	DC Reverse Voltage	1200	V
V_{GSmax}	Gate-source voltage, max. transient voltage	-10/+25	
V_{GSmax}	Gate-source voltage, max. static voltage	-8/+22	
V_{GSop}	Gate-source voltage	-5/+18	
I_D	Continuous drain current ($V_{GS} = 18V$)	58	A
	Continuous drain current ($V_{GS} = 18V$), $T_C = 100^{\circ}C$	41	
$I_{D(pulse)}$	Pulsed drain current (Pulse width limited by T_{jmax})	145	A
P_{tot}	Power dissipation		W
T_j	Operating junction temperature	-55 to 175	$^{\circ}C$
T_{stg}	Storage temperature	-55 to 175	$^{\circ}C$
M	Mounting torque	0.7	Nm

Thermal and Mechanical Characteristics

Symbol	Parameter	Min	Typ	Max	Unit
$R_{\theta JC}$	Junction-to-case thermal Resistance	-		-	$^{\circ}C/W$
$R_{\theta JA}$	Junction-to-ambient thermal Resistance	-	-		$^{\circ}C/W$

Static Electrical Characteristics ($T_A = 25^\circ\text{C}$, unless specified otherwise)

Symbol	Parameter	Test Conditions	Min	Typ	Max	Unit
BV_{DSS}	Drain-Source Breakdown Voltage	$V_{GS} = 0V, I_D = 100\mu A$	1200	-	-	V
$V_{GS(th)}$	Gate-Source Threshold Voltage	$V_{DS} = V_{GS}, I_D = 10mA^a$	1.8	3.2	4.2	
		$V_{DS} = V_{GS}, I_D = 10mA,$ $T_j = 175^\circ\text{C}^a$	-	2.4	-	
I_{DSS}	Drain-Source Leakage current	$V_{DS} = 1200V, V_{GS} = 0V$	-	1	150	μA
I_{GSS}	Gate-Source leakage current	$-10V < V_{GS} < 25V$	-	1	100	nA
$R_{DS(on)}$	Drain-Source ON Resistance	$V_{GS} = 15V, I_D = 40A$	-	37	-	m Ω
		$V_{GS} = 18V, I_D = 40A$	-	32	42	
		$V_{GS} = 18V, I_D = 40A,$ $T_j = 175^\circ\text{C}$	-	48	-	
g_{fs}	Transconductance	$V_{DS} = 20V, I_D = 40A$	-	24	-	S
		$V_{DS} = 20V, I_D = 40A,$ $T_j = 175^\circ\text{C}$	-	20	-	
$R_{g(int)}$	Internal gate resistance	$f = 1MHz, V_{AC} = 25mV$	-	3.6	-	Ω

^a Pre-condition V_{th} , as per JEDEC standard JEP183A, (Revision of JEP183 January 2021)

Dynamic Characteristics ($T_A = 25^\circ\text{C}$, unless specified otherwise)

Symbol	Parameter	Test conditions	Min	Typ	Max	Unit
C_{iss}	Input Capacitance	$V_{GS} = 0V, V_{DS} = 1000V,$ $f = 1MHz, V_{AC} = 25mV$	-	2090	-	pF
C_{oss}	Output Capacitance		-	86	-	
C_{riss}	Reverse Transfer Capacitance		-	2	-	
E_{oss}	C_{oss} stored energy		-	35	-	μJ
Q_{gs}	Gate-Source Gate Charge	$V_{DD} = 800V, V_{GS} = -5/+18V,$ $I_D = 40A, I_{GS} = 1mA$	-	30	-	nC
Q_{gd}	Gate-Drain Gate Charge		-	27	-	
Q_g	Total Gate Charge		-	91	-	

Switching Characteristics ($T_A = 25\text{ }^\circ\text{C}$, unless specified otherwise)

Symbol	Parameter	Test conditions	Min	Typ	Max	Unit
$T_{d(on)}$	Turn-on delay time					ns
T_r	Rise time					
$T_{d(off)}$	Turn-off delay time					
T_f	Fall time					
E_{on}	Turn On Switching Energy					μJ
E_{off}	Turn Off Switching Energy					
$T_{d(on)}$	Turn-on delay time					ns
T_r	Rise time					
$T_{d(off)}$	Turn-off delay time					
T_f	Fall time					
E_{on}	Turn On Switching Energy					μJ
E_{off}	Turn Off Switching Energy					

Body Diode Characteristics ($T_A = 25\text{ }^\circ\text{C}$, unless specified otherwise)

Symbol	Parameter	Test conditions	Min	Typ	Max	Unit
V_{SD}	Body Diode Forward Voltage					V
I_S	Continuous diode forward current					A
$I_{S(pulse)}$	Diode pulse current					A
t_{rr}	Reverse recovery time					ns
Q_{rr}	Reverse recovery charge					μC
I_{rrm}	Peak reverse recovery current					A
t_{rr}	Reverse recovery time					ns
Q_{rr}	Reverse recovery charge					μC
I_{rrm}	Peak reverse recovery current					A

Electrical Characteristic Diagrams

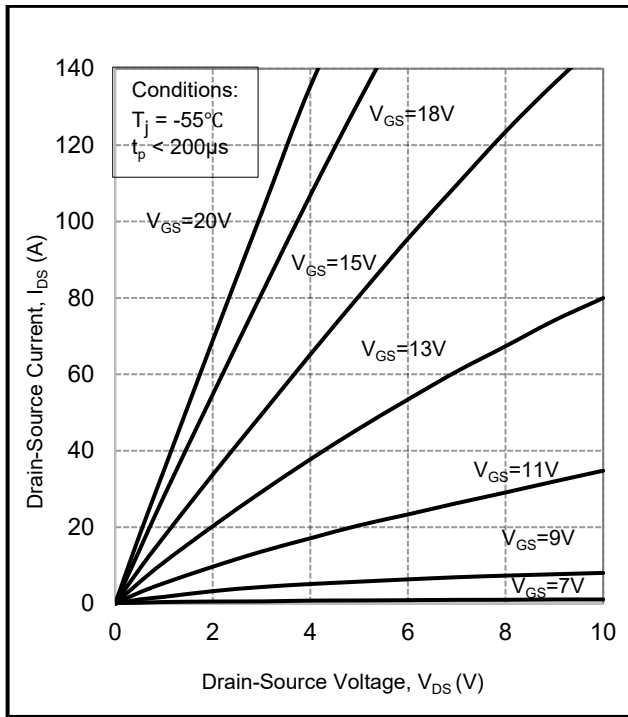

Figure 1. Output characteristics at $T_j = -55^\circ\text{C}$

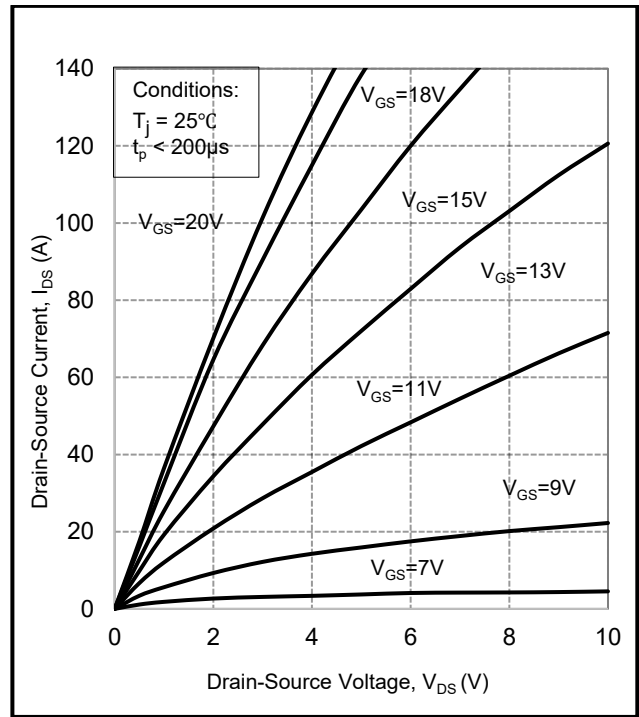

Figure 2. Output characteristics at $T_j = 25^\circ\text{C}$

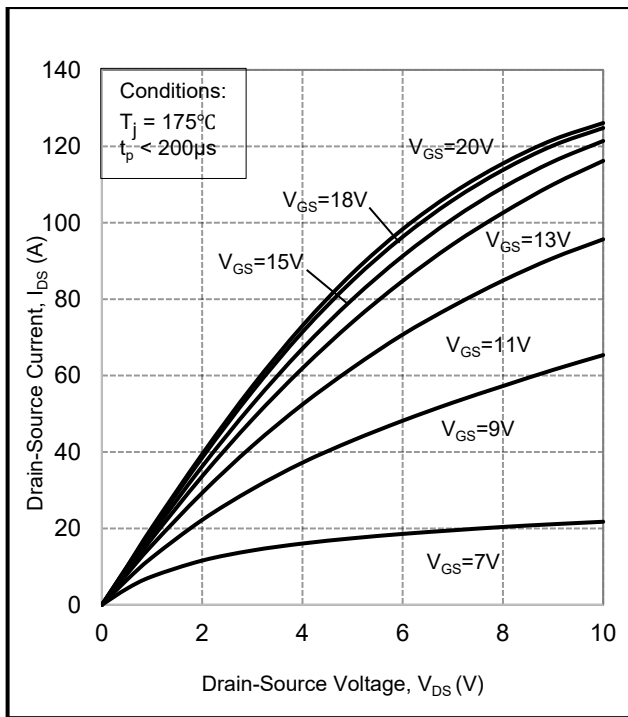

Figure 3. Output characteristics at $T_j = 175^\circ\text{C}$

Figure 4. Normalized on-resistance vs. temperature

Figure 5. On-resistance vs. drain current for various temperatures

Figure 6. On-resistance vs. temperature for various gate voltages

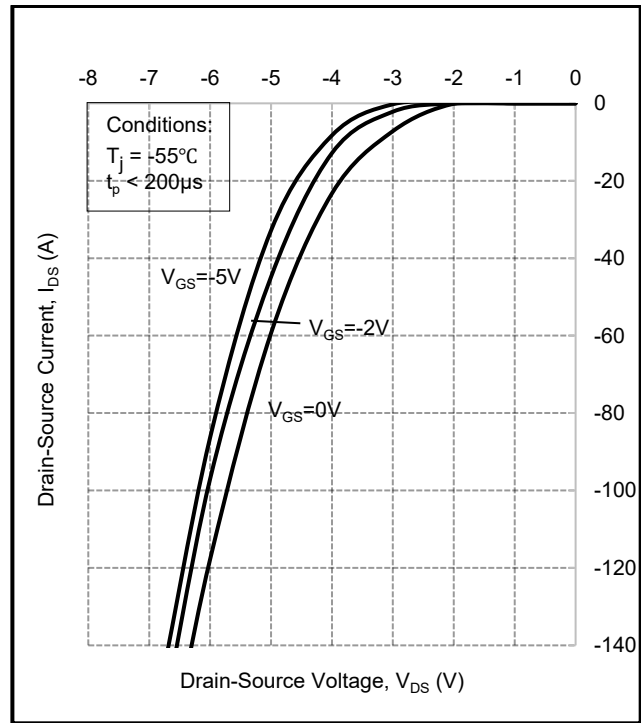

Figure 7. Transfer characteristic for various junction temperatures

Figure 8. Body diode characteristic at $T_j = -55^\circ\text{C}$

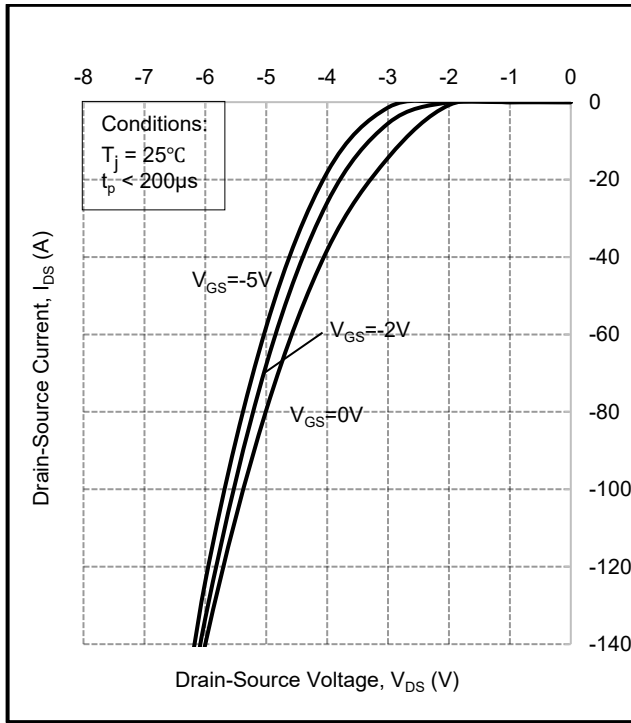

Figure 9. Body diode characteristic at $T_j = 25^\circ\text{C}$

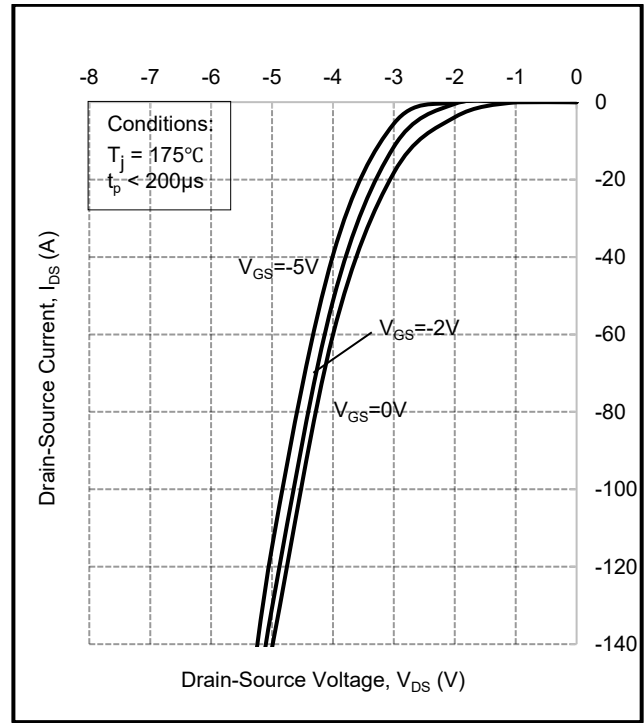

Figure 10. Body diode characteristic at $T_j = 175^\circ\text{C}$

Figure 11. Threshold voltage vs. temperature

Figure 12. Gate charge characteristics

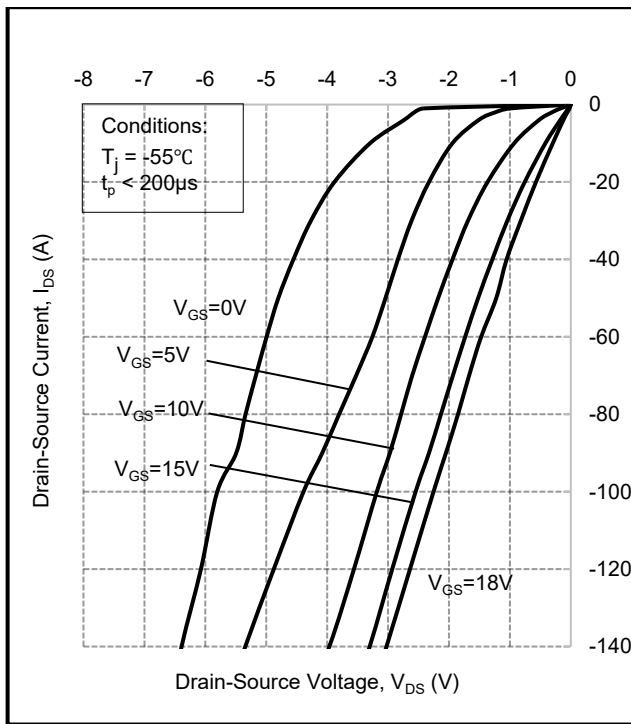

Figure 13. 3rd quadrant characteristic at $T_j = -55^\circ\text{C}$

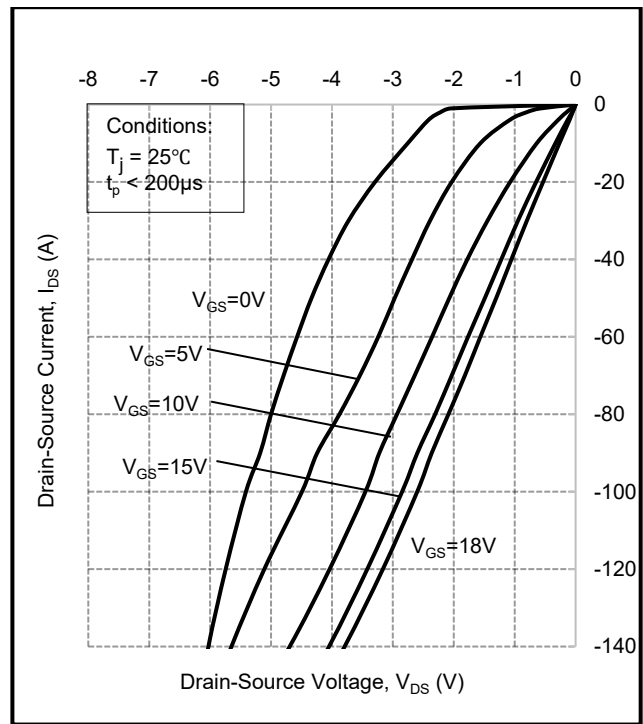

Figure 14. 3rd quadrant characteristic at $T_j = 25^\circ\text{C}$

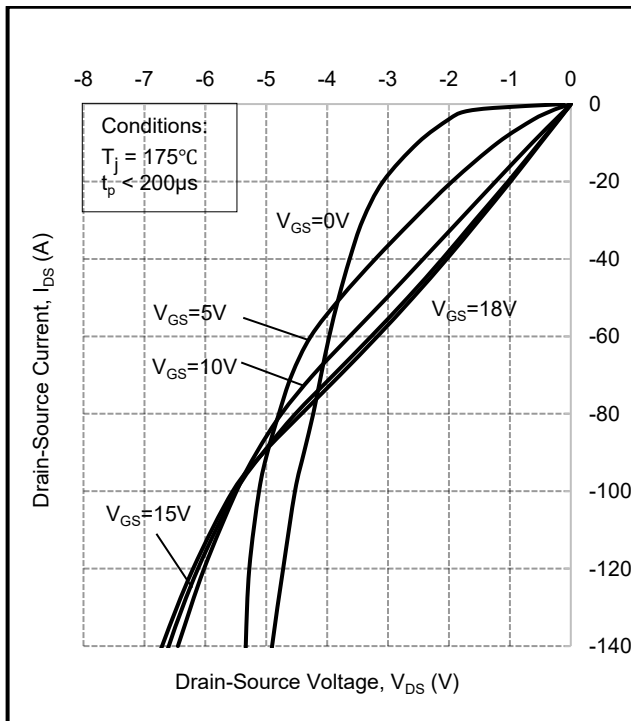

Figure 15. 3rd quadrant characteristic at $T_j = 175^\circ\text{C}$

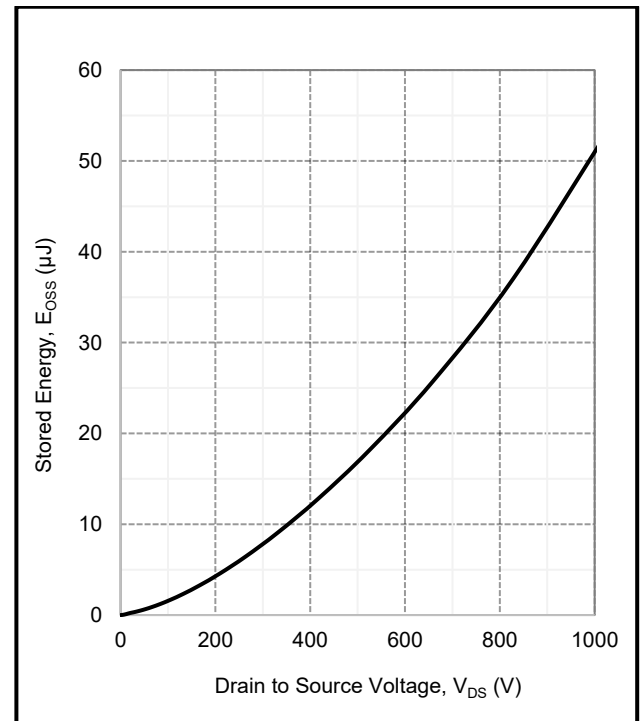

Figure 16. Output capacitor stored energy

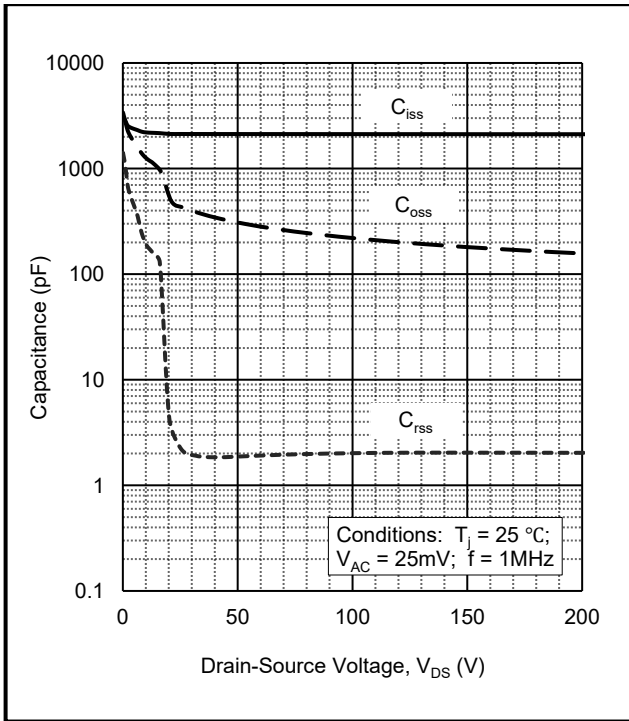

Figure 17. Capacitance vs. drain-source voltage (0 - 200V)

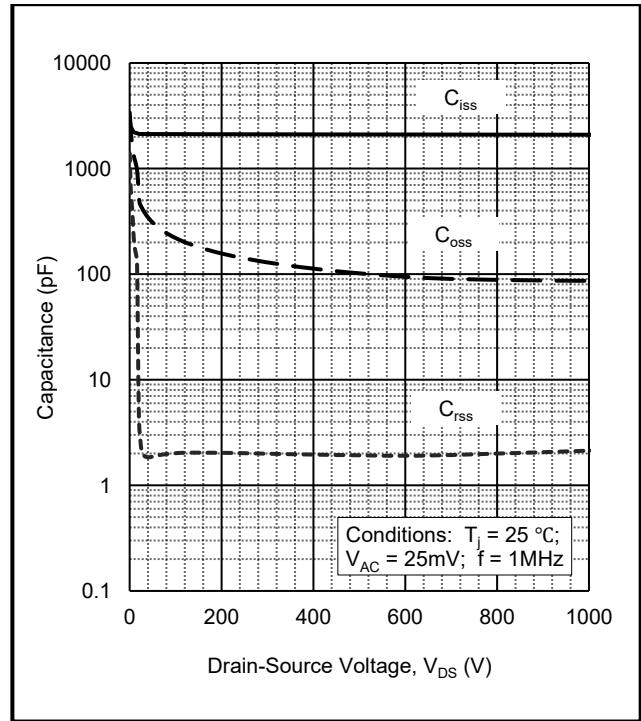

Figure 18. Capacitance vs. drain-source voltage (0 - 1000V)

Figure 19. Continuous drain current derating vs. temperature

Figure 20. Maximum power dissipation derating vs. temperature

Figure 21. Switching times definition

Figure 22. Clamped inductive switching waveform test circuit

Package Information:

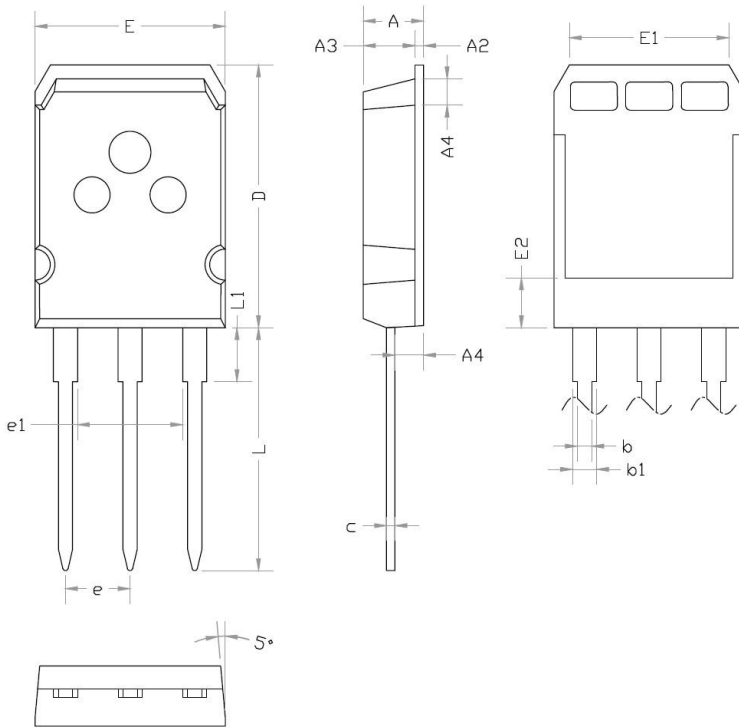

SYMBOL	mm
A	5.03 mm
A1	2.39 mm
A2	0.7 mm
A3	4.33 mm
A4	2.2 mm
b	1.19 mm
b1	2.01 mm
c	0.7 mm
D	21.94 mm
E	15.9 mm
E1	13.35 mm
E2	4.17 mm
e	5.4 mm
e1	8.79 mm
L	20.27 mm
L1	4.51 mm

Ordering Information

Part number	AMR030V120E2i
Package	TO-247i-3L
Unit quantity	300 EA
Packing type	Tube