

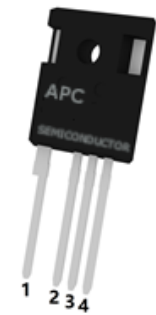

High Power SiC MOSFET Transistor

AMR032V120H1

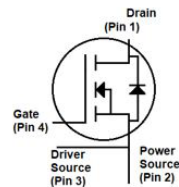

Applications:

- Solar Inverters
- Uninterrupted power supplies
- Switch mode power supplies
- Motor drives

Features:

- High blocking voltage with low on-resistance
- High switching speed with low capacitance
- Very low switching losses
- Excellent avalanche ruggedness
- Very fast and robust intrinsic body diode with low reverse recovery

Absolute Maximum Ratings (T_{amb}=25°C, unless specified otherwise)

Symbol	Parameter	AMR032V120H1	Unit
V _{DS}	DC Reverse Voltage	1200	V
V _{GSmax}	Gate-source voltage, max. transient voltage	-10/+22	
V _{GSmax}	Gate-source voltage, max. static voltage	-8/+19	
V _{GSop}	Gate-source voltage	-4/ +15	
I _D	Continuous drain current (V _{GS} = 15V), T _C = 25°C	77	A
	Continuous drain current (V _{GS} = 15V), T _C = 100°C	54	
I _{D(pulse)}	Pulsed drain current	189	A
P _{tot}	Power dissipation	417	W
T _j	Operating junction temperature	-55 to 175	°C
T _{stg}	Storage temperature	-55 to 175	°C

Thermal and Mechanical Characteristics

Symbol	Parameter	Test conditions	Min	Typ	Max	Unit
R _{θJC}	Junction-to-case thermal Resistance		-	0.30	-	°C/W
R _{θJA}	Junction-to-ambient thermal Resistance		-	-	40	°C/W

Static Electrical Characteristics ($T_A = 25^\circ\text{C}$, unless specified otherwise)

Symbol	Parameter	Test Conditions	Min	Typ	Max	Unit
BV_{DSS}	Drain-Source Breakdown Voltage	$V_{GS} = 0\text{ V}, I_D = 100\text{ }\mu\text{A}$	1200	-	-	V
$V_{GS(th)}$	Gate-Source Threshold Voltage	$V_{DS} = V_{GS}, I_D = 11.5\text{ mA}$	1.8	2.9	4.0	
		$V_{DS} = V_{GS}, I_D = 11.5\text{ mA}, T_J = 175^\circ\text{C}$	-	2.0	-	
I_{DSS}	Drain-Source Leakage current	$V_{DS} = 1200\text{ V}, V_{GS} = 0\text{ V}$	-	1	50	μA
I_{GSS}	Gate-Source leakage current	$V_{GS} = 15\text{ V}, V_{DS} = 0\text{ V}$	-	1	250	nA
$R_{DS(on)}$	Drain-Source ON Resistance	$V_{GS} = 15\text{ V}, I_D = 40\text{ A}$	18	32	43	m Ω
		$V_{GS} = 15\text{ V}, I_D = 40\text{ A}, T_J = 175^\circ\text{C}$	-	45	-	
g_{fs}	Transconductance	$V_{DS} = 20\text{ V}, I_D = 40\text{ A}$	-	28	-	S
		$V_{DS} = 20\text{ V}, I_D = 40\text{ A}, T_J = 175^\circ\text{C}$	-	32	-	
$R_{g(int)}$	Internal gate resistance	$f = 1\text{ MHz}, V_{AC} = 25\text{ mV}$	-	2.6	-	Ω

Dynamic Characteristics ($T_A = 25^\circ\text{C}$, unless specified otherwise)

Symbol	Parameter	Test conditions	Min	Typ	Max	Unit
C_{iss}	Input Capacitance	$V_{GS} = 0\text{ V}, V_{DS} = 1000\text{ V}, f = 100\text{ kHz}, V_{AC} = 25\text{ mV}$	-	3318	-	pF
C_{rss}	Reverse Transfer Capacitance		-	7	-	
C_{oss}	Output Capacitance		-	150	-	
E_{oss}	C_{oss} stored energy		-	83	-	μJ
Q_{gs}	Gate-Source Gate Charge	$V_{DD} = 800\text{ V}, V_{GS} = -4/+15\text{ V}, I_D = 40\text{ A}, I_{GS} = 1\text{ mA}$	-	45	-	nC
Q_{gd}	Gate-Drain Gate Charge		-	44	-	
Q_g	Total Gate Charge		-	134	-	

Switching Characteristics ($T_A = 25^\circ\text{C}$, unless specified otherwise)

Symbol	Parameter	Test conditions	Min	Typ	Max	Unit
$T_{d(on)}$	Turn-on delay time	$V_{DD} = 800V,$ $V_{GS} = -4/+15V, I_D = 40A,$ $R_{G(ext)} = 2.4\Omega, L = 110\mu H,$ $T_j = 25^\circ C$	-	20	-	ns
T_r	Rise time		-	27	-	
$T_{d(off)}$	Turn-off delay time		-	42	-	
T_f	Fall time		-	11	-	
E_{on}	Turn On Switching Energy		-	724	-	μJ
E_{off}	Turn Off Switching Energy	-	59	-		
$T_{d(on)}$	Turn-on delay time	$V_{DD} = 800V,$ $V_{GS} = -4/+15V, I_D = 40A,$ $R_{G(ext)} = 2.4\Omega, L = 110\mu H,$ $T_j = 175^\circ C$	-	18	-	ns
T_r	Rise time		-	29	-	
$T_{d(off)}$	Turn-off delay time		-	55	-	
T_f	Fall time		-	14	-	
E_{on}	Turn On Switching Energy		-	961	-	μJ
E_{off}	Turn Off Switching Energy		-	152	-	

Body Diode Characteristics ($T_A = 25^\circ C$, unless specified otherwise)

Symbol	Parameter	Test conditions	Min	Typ	Max	Unit
V_{SD}	Body Diode Forward Voltage	$V_{GS} = -4V, I_{SD} = 20A$		3.6		V
		$V_{GS} = -4V, I_{SD} = 20A,$ $T_j = 175^\circ C$		3.2		
I_S	Continuous diode forward current	$T_C = 25^\circ C$	-	-	77	A
t_{rr}	Reverse recovery time	$V_{GS} = -4V, I_{SD} = 40A,$ $V_R = 800V,$	-	15	-	ns
Q_{rr}	Reverse recovery charge		-	0.34	-	μC
I_{rrm}	Peak reverse recovery current	$di/dt = 3.93kA/\mu s,$ $T_j = 25^\circ C$	-	35	-	A
t_{rr}	Reverse recovery time	$V_{GS} = -4V, I_{SD} = 40A,$ $V_R = 800V,$	-	23	-	ns
Q_{rr}	Reverse recovery charge		-	0.76	-	μC
I_{rrm}	Peak reverse recovery current	$di/dt = 3.98kA/\mu s,$ $T_j = 175^\circ C$	-	56	-	A

Electrical Characteristic Diagrams

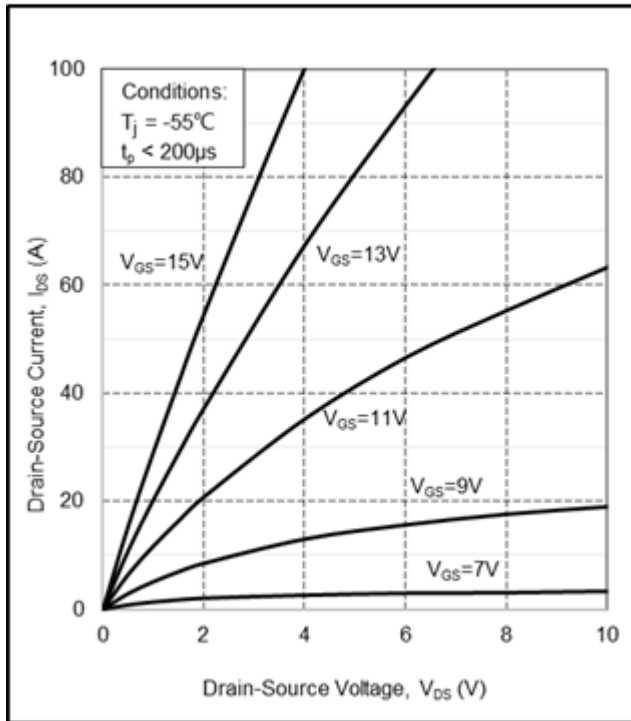

Figure 1. Output characteristics at $T_j = -55^\circ\text{C}$

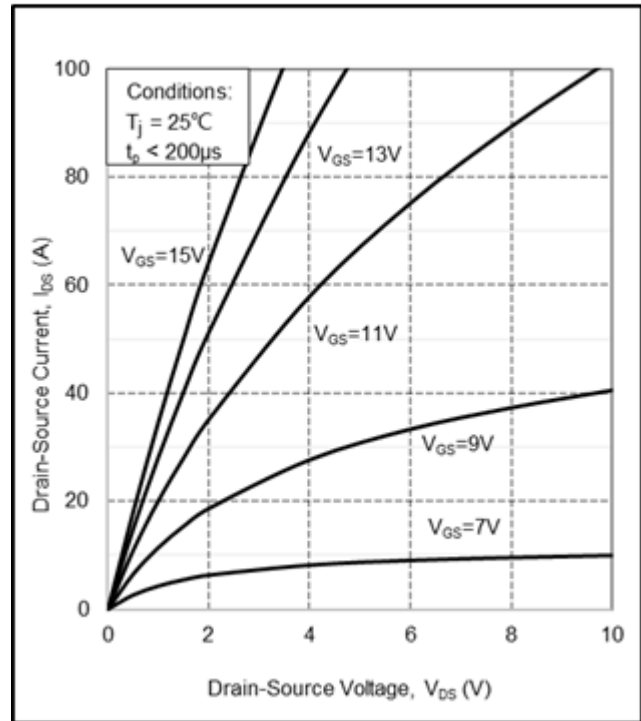

Figure 2. Output characteristics at $T_j = 25^\circ\text{C}$

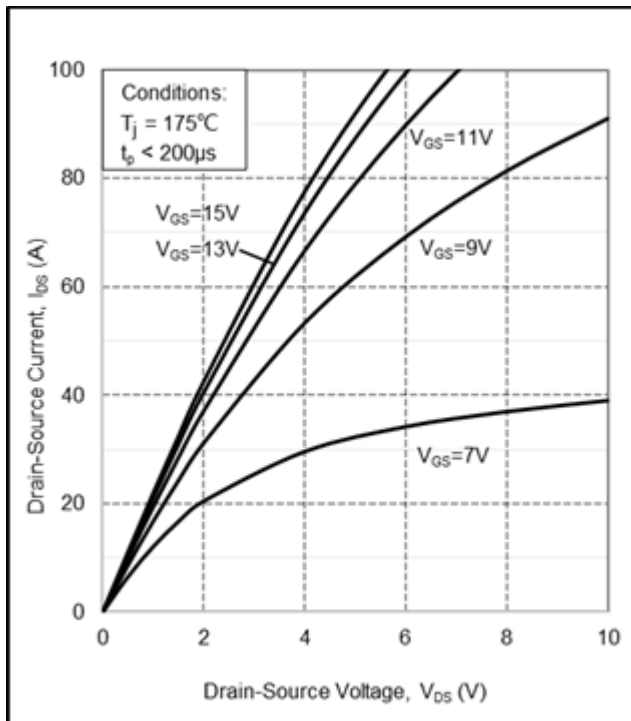

Figure 3. Output characteristics at $T_j = 175^\circ\text{C}$

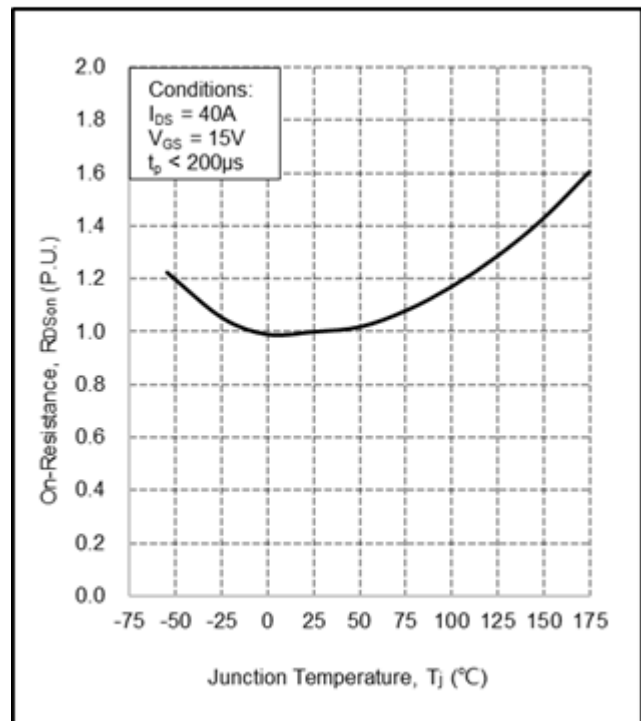

Figure 4. Normalized on-resistance vs. temperature

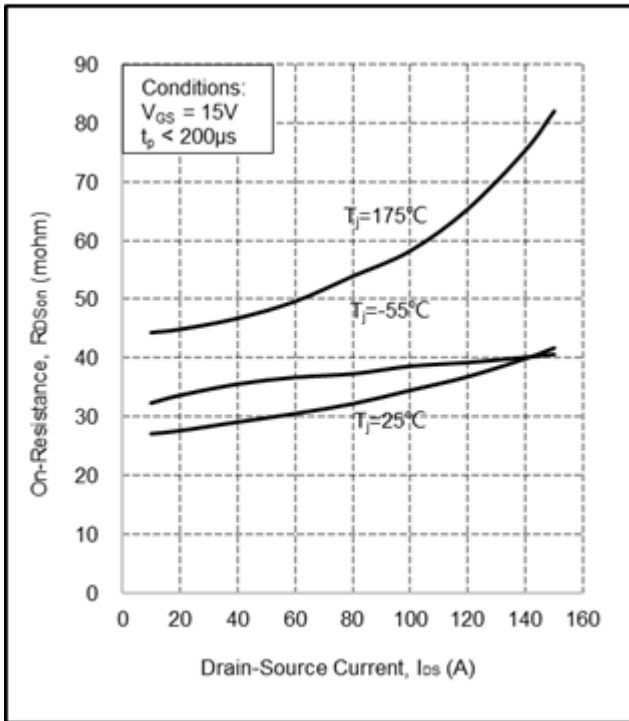

Figure 5. On-resistance vs. drain current for various temperatures

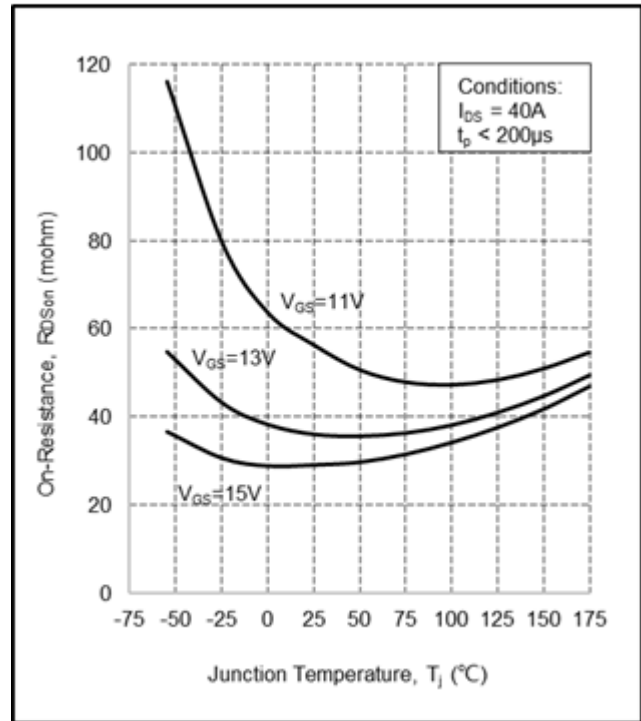

Figure 6. On-resistance vs. temperature for various gate voltages

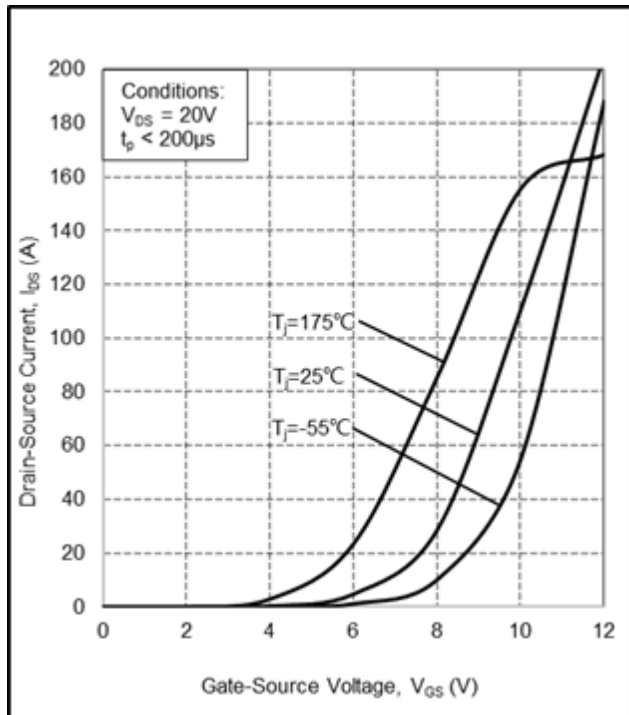

Figure 7. Transfer characteristic for various junction temperatures

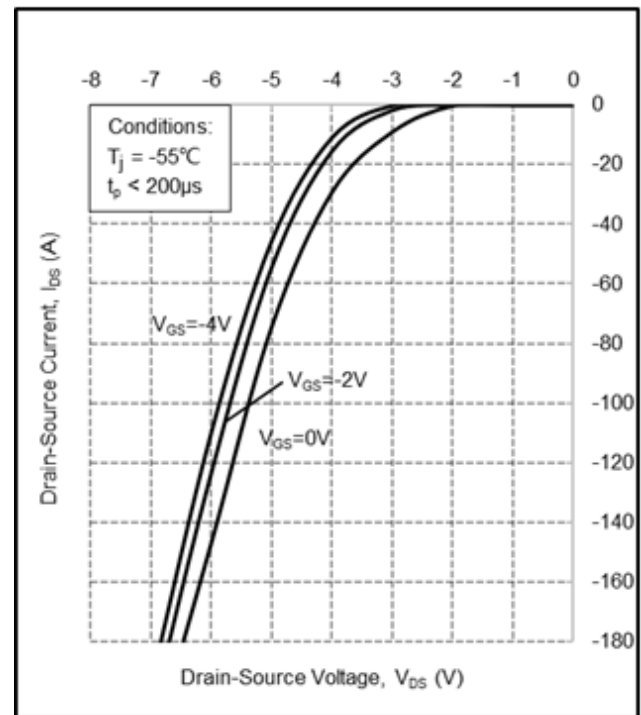

Figure 8. Body diode characteristic at $T_J = -55^\circ\text{C}$

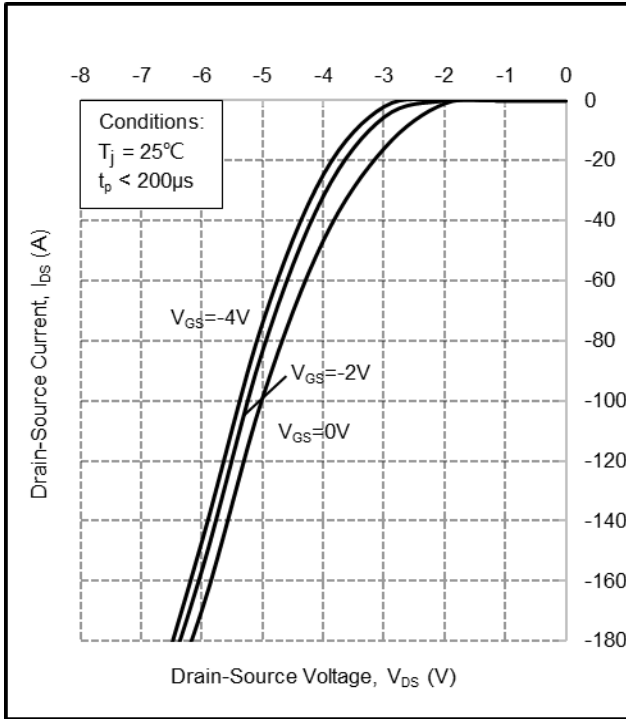

Figure 9. Body diode characteristic at $T_j = 25^\circ\text{C}$

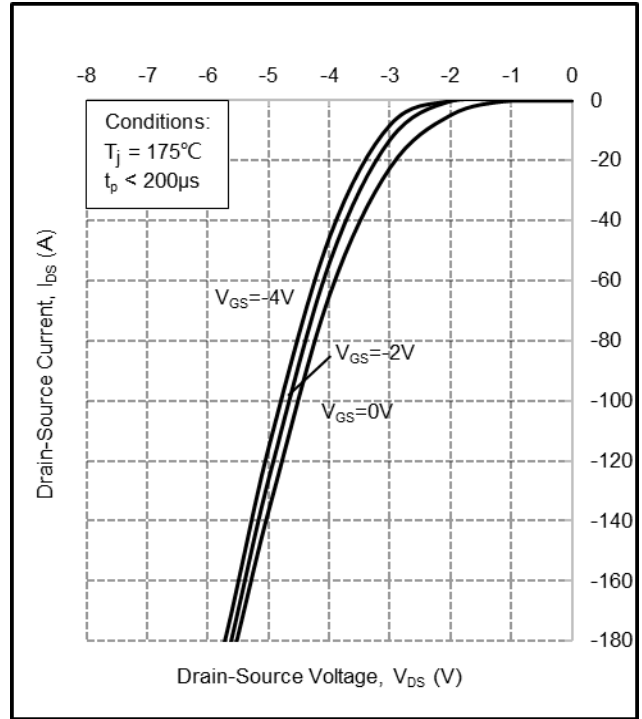

Figure 10. Body diode characteristic at $T_j = 175^\circ\text{C}$

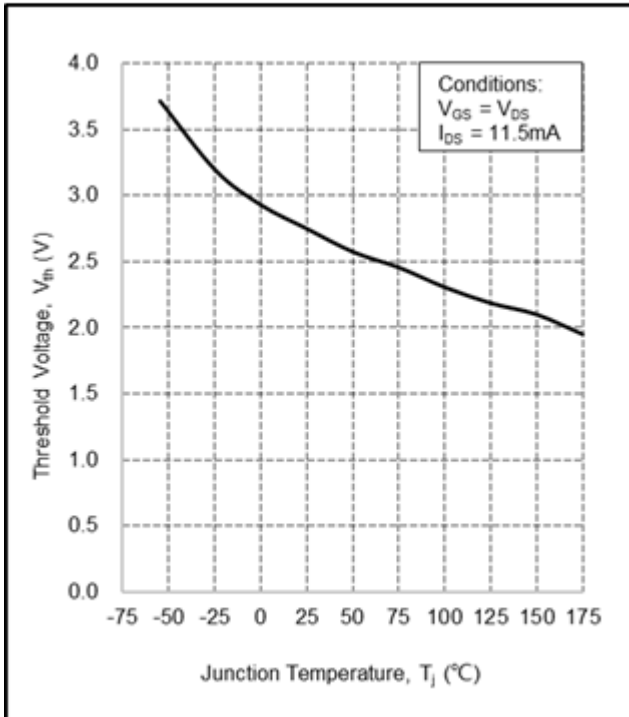

Figure 11. Threshold voltage vs. temperature

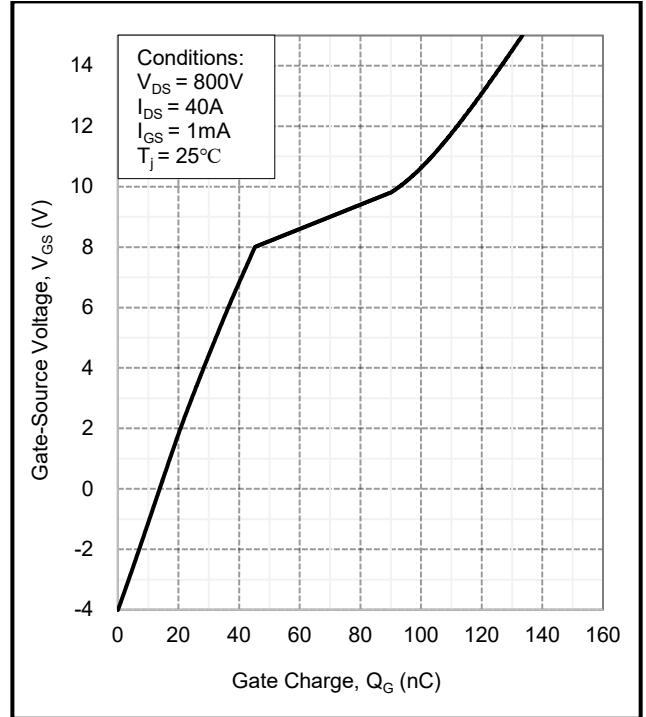

Figure 12. Gate charge characteristics

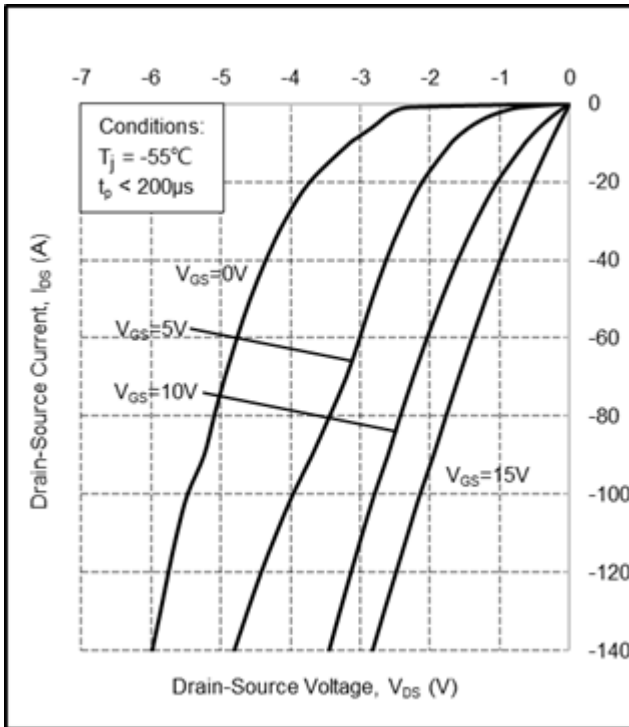

Figure 13. 3rd quadrant characteristic
at $T_j = -55^\circ\text{C}$

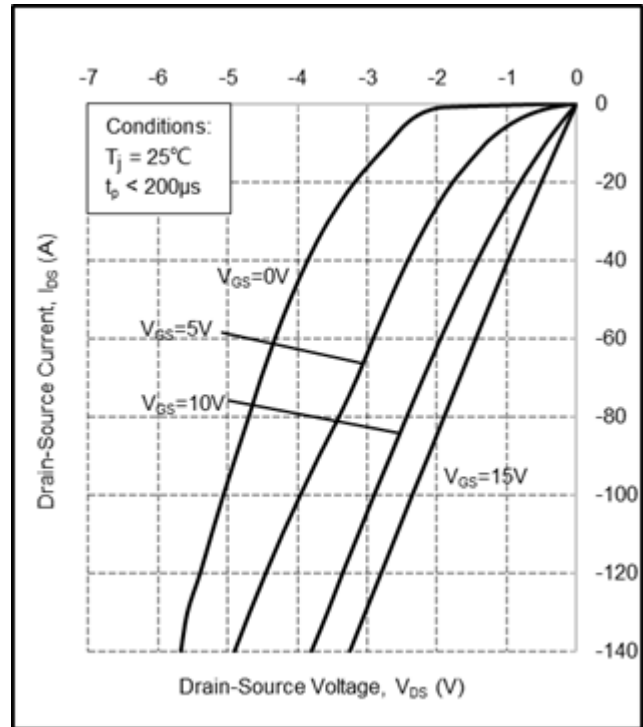

Figure 14. 3rd quadrant characteristic
at $T_j = 25^\circ\text{C}$

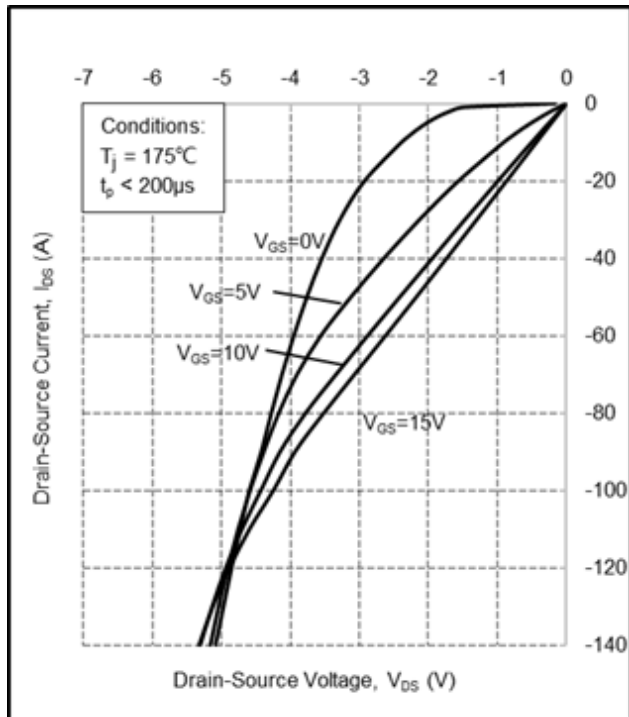

Figure 15. 3rd quadrant characteristic
at $T_j = 175^\circ\text{C}$

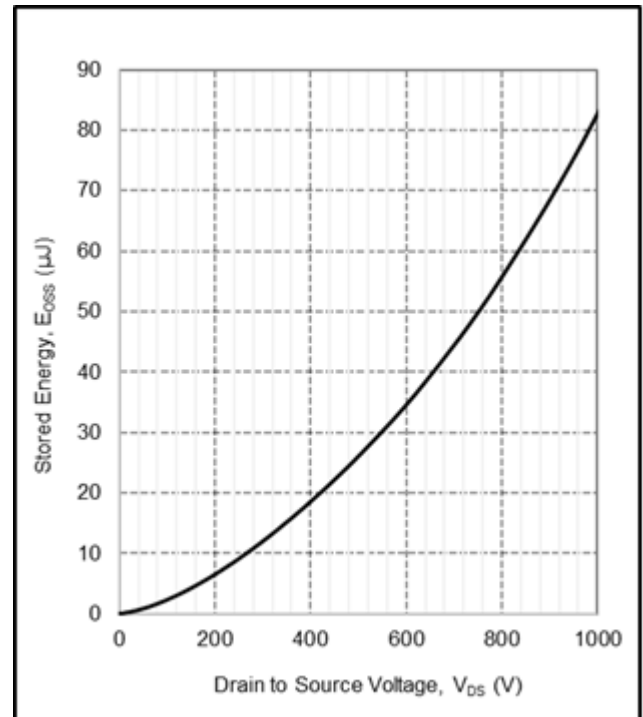

Figure 16. Output capacitor stored energy

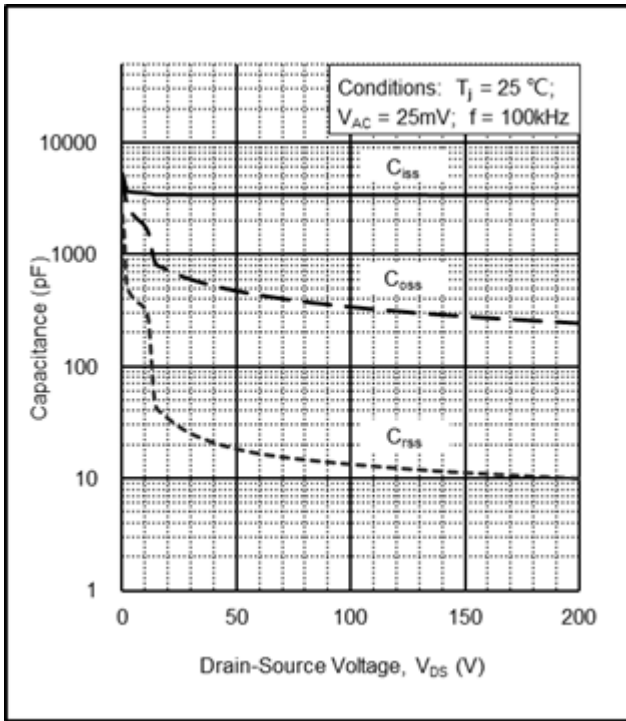

Figure 17. Capacitance vs. drain-source voltage (0 - 200V)

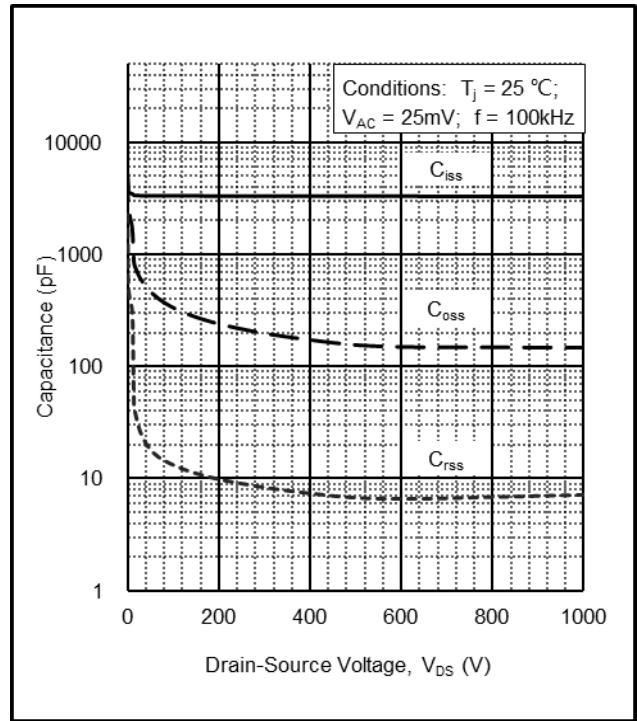

Figure 18. Capacitance vs. drain-source voltage (0 - 1000V)

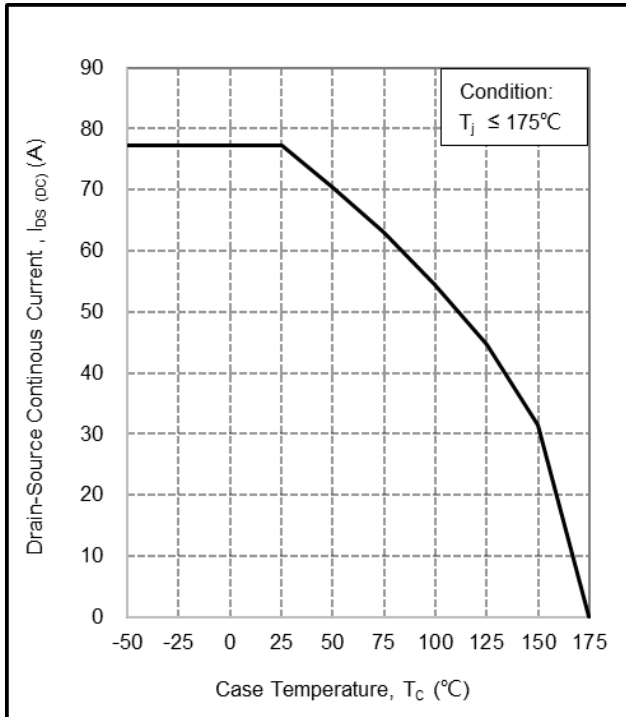

Figure 19. Continuous drain current derating vs. temperature

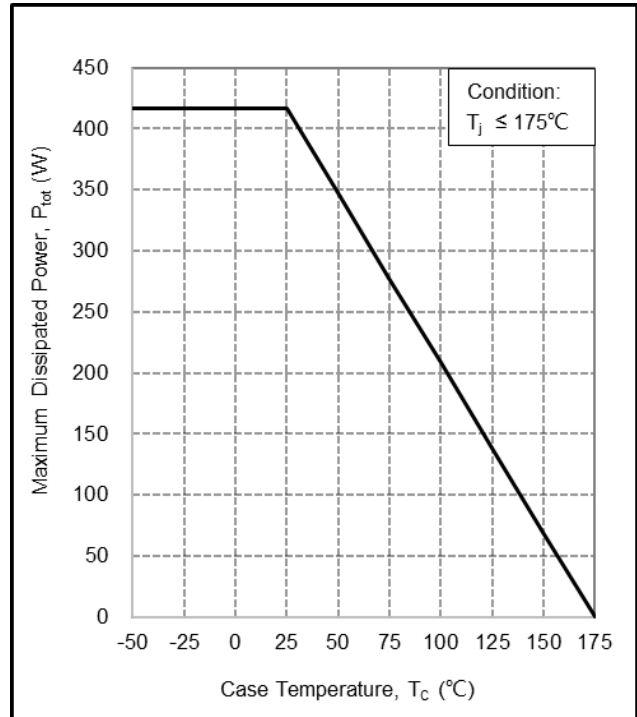

Figure 20. Maximum power dissipation derating vs. temperature

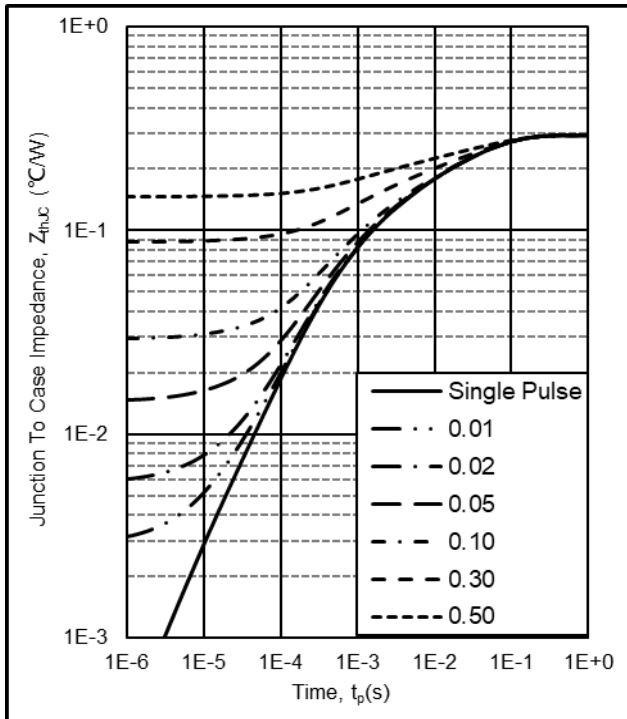

Figure 21. Transient thermal impedance
(Junction - Case)

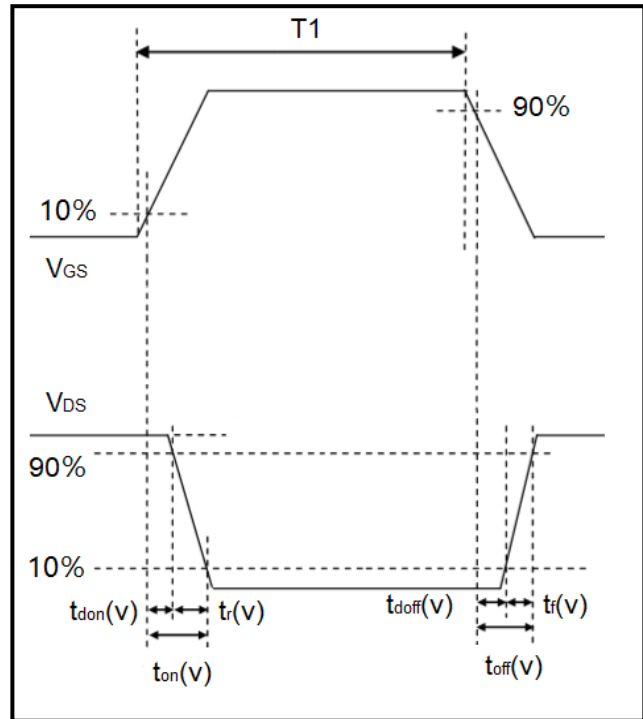

Figure 22. Switching times definition

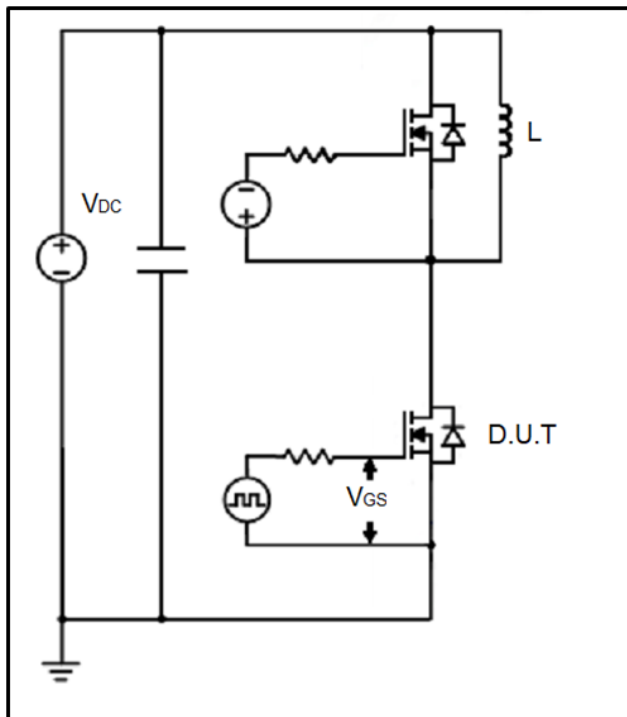
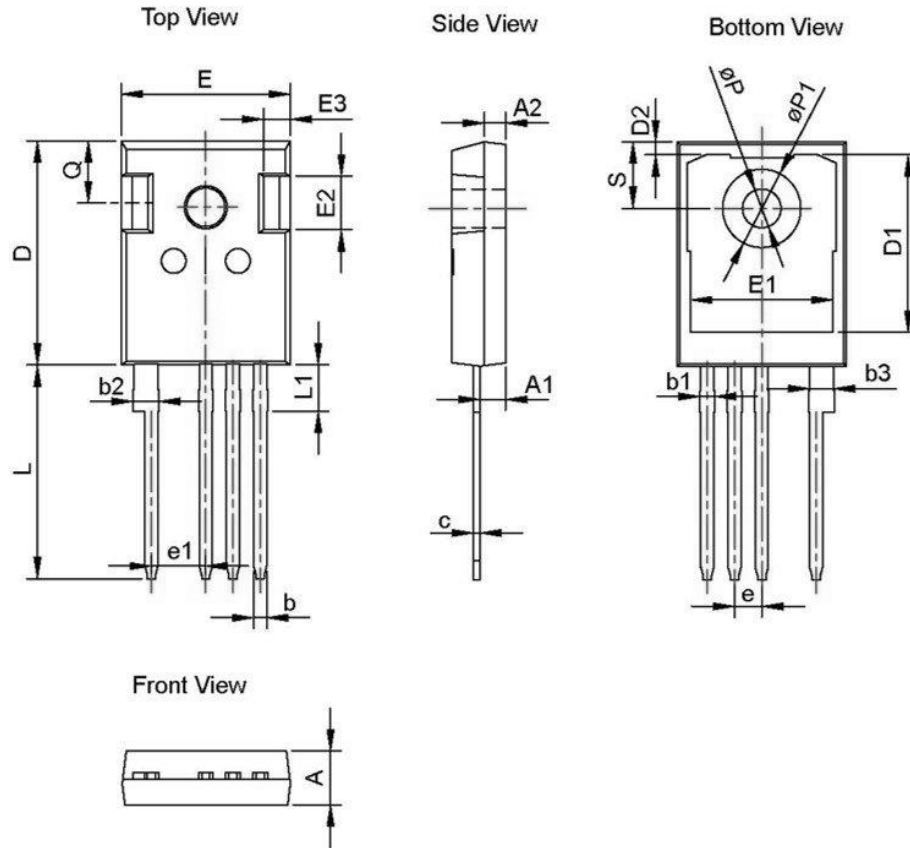

Figure 23. Clamped inductive switching waveform
test circuit

Package Information:



Dimension unit: [mm]			
Symbol	Min	Nom	Max
A	4.80	5.00	5.20
A1	2.21	2.41	2.61
A2	1.85	2.00	2.15
b	1.11	1.21	1.36
b1	1.11	1.37	1.57
b2	2.24	2.40	2.60
b3	2.11	2.21	2.36
c	0.51	0.60	0.75
D	20.70	20.90	21.30
D1	15.92	16.22	16.52
D2	1.00	1.20	1.35
E	15.50	15.80	16.10
E1	13.00	13.30	13.60
E2	4.80	5.00	5.20
E3	2.30	2.50	2.70
e	2.54 BSC		
e1	5.08 BSC		

Dimension unit: [mm]			
Symbol	Min	Nom	Max
L	19.62	19.92	20.22
L1	-	-	4.30
ϕP	3.40	3.60	3.80
$\phi P1$	-	-	7.30
Q	5.40	5.80	6.20
S	6.20 BSC		

Recommended Solder Pad Layout

Note: All dimensions are in mm

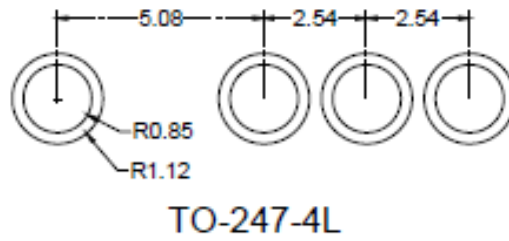

Ordering Information

Part number	AMR032V120H1
Package	TO-247-4L
Unit quantity	300 EA
Packing type	Tube

For more information, visit <https://www.apowerc2.com>