

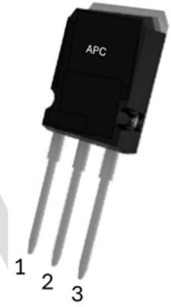

SiC Power MOSFET with Ceramic Isolated Baseplate Tab

AMR065V065E2i

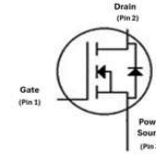

Applications:

- Solar Inverters
- Uninterrupted power supplies
- Switch mode power supplies
- Motor drives

Features:

- High blocking voltage with low on-resistance
- High switching speed with low capacitance
- Very low switching losses
- Excellent avalanche ruggedness
- Very fast and robust intrinsic body diode with low reverse recovery
- 0V turn-off V_{gs} for gate driving ease
- RoHS compliant

Absolute Maximum Ratings ($T_{amb}=25^{\circ}C$, unless specified otherwise)

Symbol	Parameter	Value	Unit
V_{DS}	DC Reverse Voltage	650	V
V_{GSmax}	Gate-source voltage, max. transient voltage	-11/+25	
V_{GSmax}	Gate-source voltage, max. static voltage	-10/+22	
V_{GSop}	Gate-source voltage	-5/+18	
I_D	Continuous drain current ($V_{GS} = 18V$)	33	A
	Continuous drain current ($V_{GS} = 18V$), $T_C = 100^{\circ}C$	23	
$I_{D(pulse)}$	Pulsed drain current (Pulse width limited by T_{jmax})	83	A
P_{tot}	Power dissipation	151	W
T_j	Operating junction temperature	-55 to 175	$^{\circ}C$
T_{stg}	Storage temperature	-55 to 175	$^{\circ}C$

Thermal and Mechanical Characteristics

Symbol	Parameter	Test conditions	Min	Typ	Max	Unit
$R_{\theta JC}$	Junction-to-case thermal Resistance		-	TBD	-	$^{\circ}C/W$
$R_{\theta JA}$	Junction-to-ambient thermal Resistance		-	-	TBD	$^{\circ}C/W$

Static Electrical Characteristics ($T_A = 25^\circ\text{C}$, unless specified otherwise)

Symbol	Parameter	Test Conditions	Min	Typ	Max	Unit
BV_{DSS}	Drain-Source Breakdown Voltage	$V_{GS} = 0V, I_D = 100\mu A$	650	-	-	V
$V_{GS(th)}$	Gate-Source Threshold Voltage	$V_{DS} = V_{GS}, I_D = 3mA^a$	1.8	3.2	4.2	
		$V_{DS} = V_{GS}, I_D = 3mA,$ $T_j = 175^\circ C^a$	-	2.1	-	
I_{DSS}	Drain-Source Leakage current	$V_{DS} = 650V, V_{GS} = 0V$	-	1	50	μA
I_{GSS}	Gate-Source leakage current	$-11V < V_{GS} < 25V$	-	1	100	nA
$R_{DS(on)}$	Drain-Source ON Resistance	$V_{GS} = 15V, I_D = 12A$	-	88	-	m Ω
		$V_{GS} = 18V, I_D = 12A$	-	65	85	
		$V_{GS} = 18V, I_D = 12A,$ $T_j = 175^\circ C$	-	80	-	
g_{fs}	Transconductance	$V_{DS} = 20V, I_D = 12A$	-	9	-	S
		$V_{DS} = 20V, I_D = 12A,$ $T_j = 175^\circ C$	-	8	-	
$R_{g(int)}$	Internal gate resistance	$f = 1MHz, V_{AC} = 25mV$	-	4.0	-	Ω

^a Pre-condition V_{th} , as per JEDEC standard JEP183A, (Revision of JEP183 January 2021)

Dynamic Characteristics ($T_A = 25^\circ\text{C}$, unless specified otherwise)

Symbol	Parameter	Test conditions	Min	Typ	Max	Unit
C_{iss}	Input Capacitance	$V_{GS} = 0V, V_{DS} = 600V,$ $f = 100kHz, V_{AC} = 25mV$	-	819	-	pF
C_{oss}	Output Capacitance		-	66	-	
C_{riss}	Reverse Transfer Capacitance		-	4	-	
E_{oss}	C_{oss} stored energy		-	13	-	μJ
Q_{gs}	Gate-Source Gate Charge	$V_{DD} = 400V, V_{GS} = -5/+18V,$ $I_D = 12A, I_{GS} = 1mA$	-	12	-	nC
Q_{gd}	Gate-Drain Gate Charge		-	8	-	
Q_g	Total Gate Charge		-	33	-	

Switching Characteristics ($T_A = 25^\circ\text{C}$, unless specified otherwise)

Symbol	Parameter	Test conditions	Min	Typ	Max	Unit	
$T_{d(\text{on})}$	Turn-on delay time	$V_{DD} = 400\text{V}$, $V_{GS} = -5/+18\text{V}^b$, $I_D = 12\text{A}$, $R_{G(\text{ext})} = 2.4\Omega$, $L = 110\mu\text{H}$	-	10	-	ns	
T_r	Rise time		-	10	-		
$T_{d(\text{off})}$	Turn-off delay time		-	19	-		
T_f	Fall time		-	10	-		
E_{on}	Turn On Switching Energy		$V_{DD} = 400\text{V}$, $V_{GS} = -5/+18\text{V}^b$, $I_D = 12\text{A}$, $R_{G(\text{ext})} = 2.4\Omega$, $L = 110\mu\text{H}$ $T_j = 175^\circ\text{C}$	-	50	-	μJ
E_{off}	Turn Off Switching Energy			-	9	-	
$T_{d(\text{on})}$	Turn-on delay time	$V_{DD} = 400\text{V}$, $V_{GS} = -5/+18\text{V}^b$, $I_D = 12\text{A}$, $R_{G(\text{ext})} = 2.4\Omega$, $L = 110\mu\text{H}$ $T_j = 175^\circ\text{C}$		-	9	-	ns
T_r	Rise time			-	10	-	
$T_{d(\text{off})}$	Turn-off delay time			-	21	-	
T_f	Fall time			-	10	-	
E_{on}	Turn On Switching Energy		$T_j = 175^\circ\text{C}$	-	55	-	μJ
E_{off}	Turn Off Switching Energy			-	9	-	

^b This SiC MOSFET can switch with driver pulses 0V to 20V with optimized PCB layouts and gate drive circuits.

Body Diode Characteristics ($T_A = 25^\circ\text{C}$, unless specified otherwise)

Symbol	Parameter	Test conditions	Min	Typ	Max	Unit
V_{SD}	Body Diode Forward Voltage	$V_{GS} = -5\text{V}$, $I_{SD} = 12\text{A}$	-	4.2	-	V
		$V_{GS} = -5\text{V}$, $I_{SD} = 12\text{A}$, $T_j = 175^\circ\text{C}$	-	3.8	-	
I_S	Continuous diode forward current	$V_{GS} = -5\text{V}$, $T_C = 25^\circ\text{C}$	-	-	32	A
$I_{S, \text{pulse}}$	Diode Pulse Current	$V_{GS} = -5\text{V}$, pulse width t_p limited by $T_{j\text{max}}$	-	-	80	A
t_{rr}	Reverse recovery time	$V_{GS} = -5\text{V}$, $I_{SD} = 12\text{A}$, $V_R = 400\text{V}$, $di_r/dt = 0.98\text{kA}/\mu\text{s}$	-	11	-	ns
Q_{rr}	Reverse recovery charge		-	0.06	-	μC
I_{rrm}	Peak reverse recovery current		-	9	-	A
t_{rr}	Reverse recovery time	$V_{GS} = -5\text{V}$, $I_{SD} = 12\text{A}$, $V_R = 400\text{V}$, $T_j = 175^\circ\text{C}$, $di_r/dt = 1.05\text{kA}/\mu\text{s}$	-	16	-	ns
Q_{rr}	Reverse recovery charge		-	0.12	-	μC
I_{rrm}	Peak reverse recovery current		-	13	-	A

Electrical Characteristic Diagrams

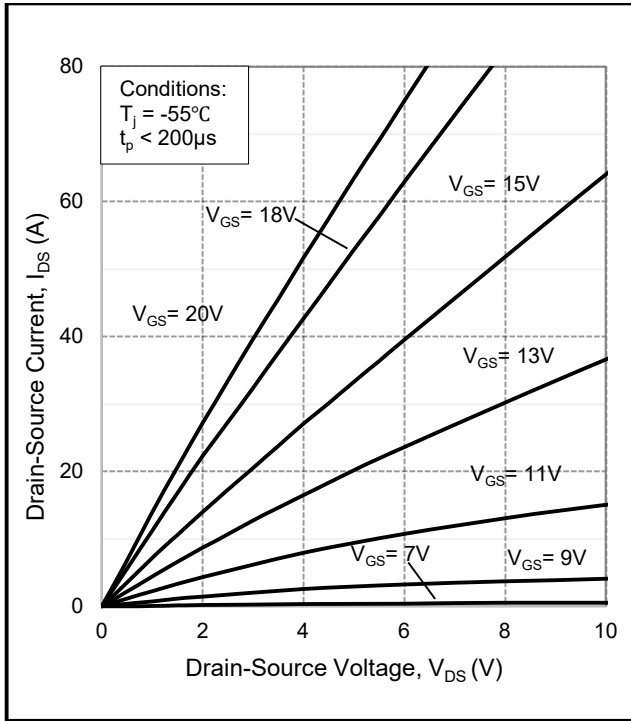

Figure 1. Output characteristics at $T_j = -55^\circ\text{C}$

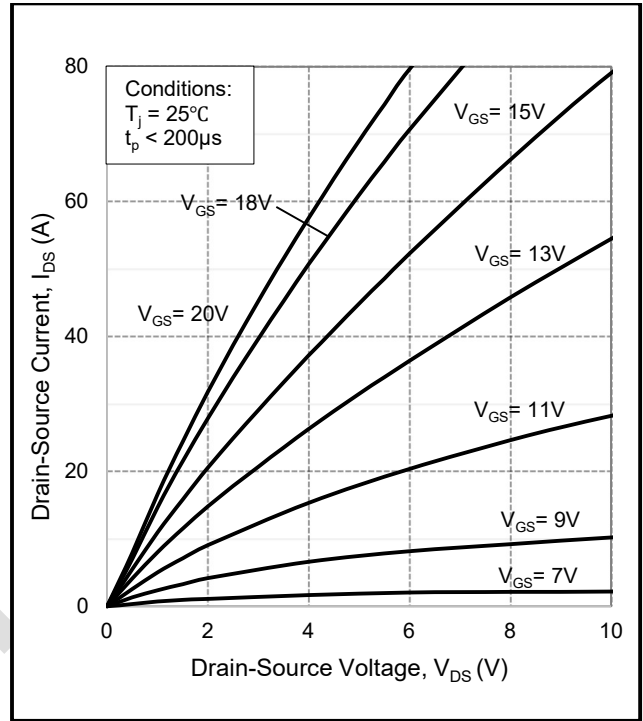

Figure 2. Output characteristics at $T_j = 25^\circ\text{C}$

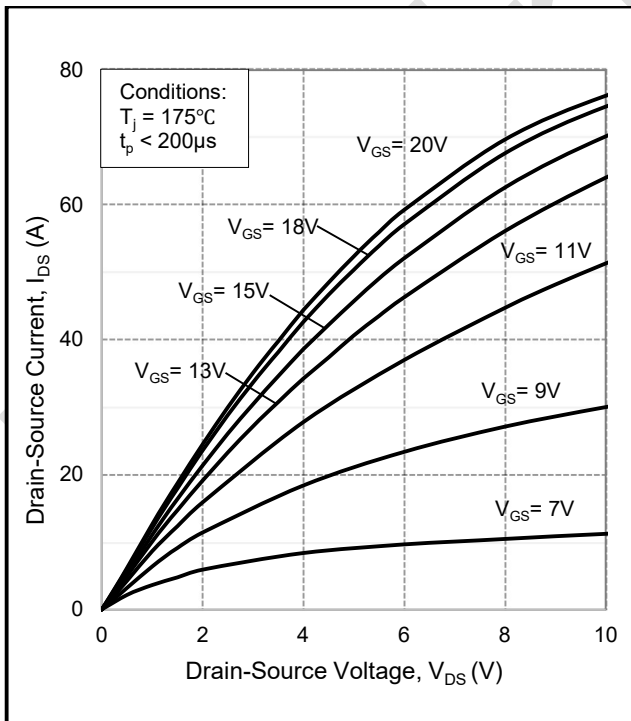

Figure 3. Output characteristics at $T_j = 175^\circ\text{C}$

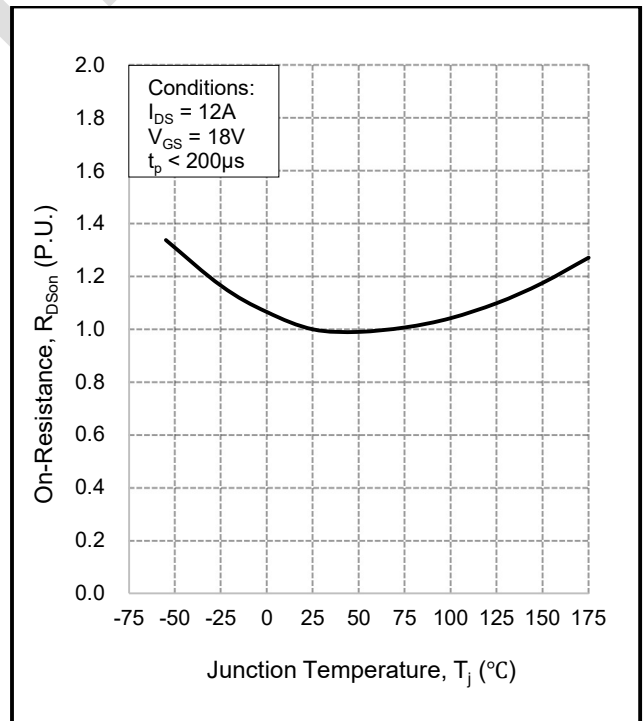

Figure 4. Normalized on-resistance vs. temperature

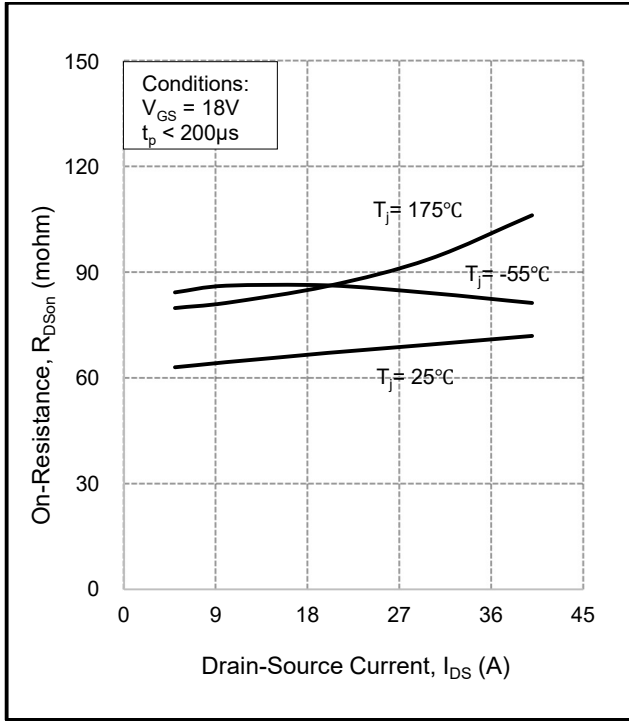

Figure 5. On-resistance vs. drain current for various temperatures

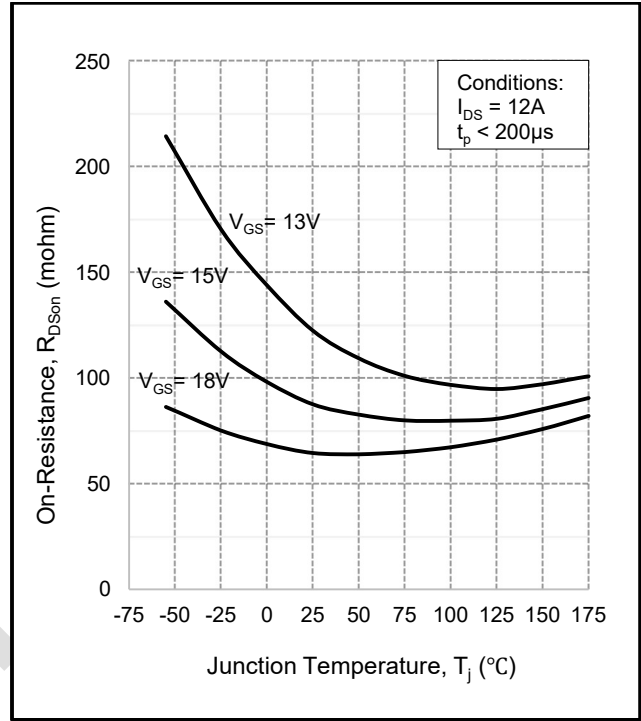

Figure 6. On-resistance vs. temperature for various gate voltages

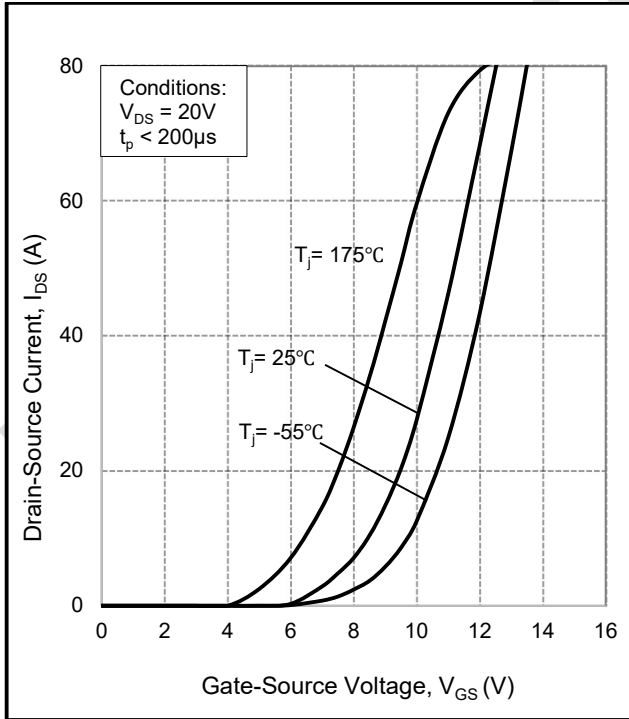

Figure 7. Transfer characteristic for various junction temperatures

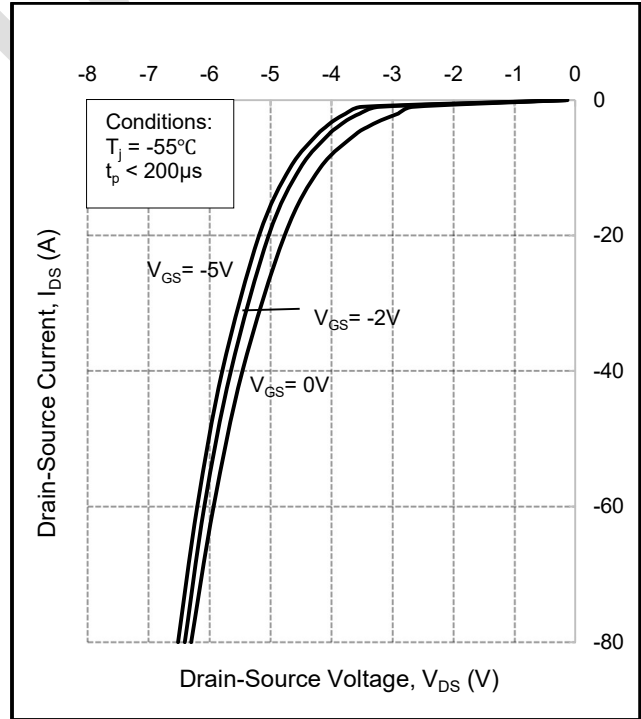

Figure 8. Body diode characteristic at $T_j = -55^\circ\text{C}$

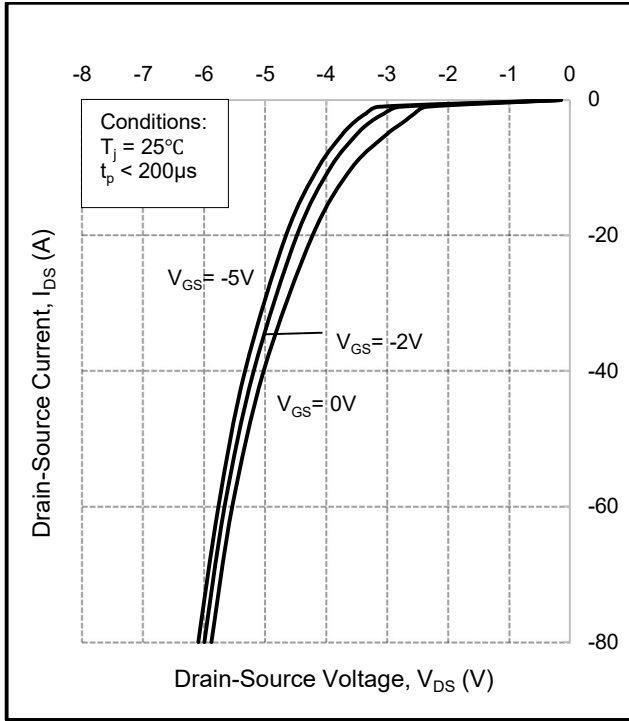

Figure 9. Body diode characteristic at $T_j = 25^\circ\text{C}$

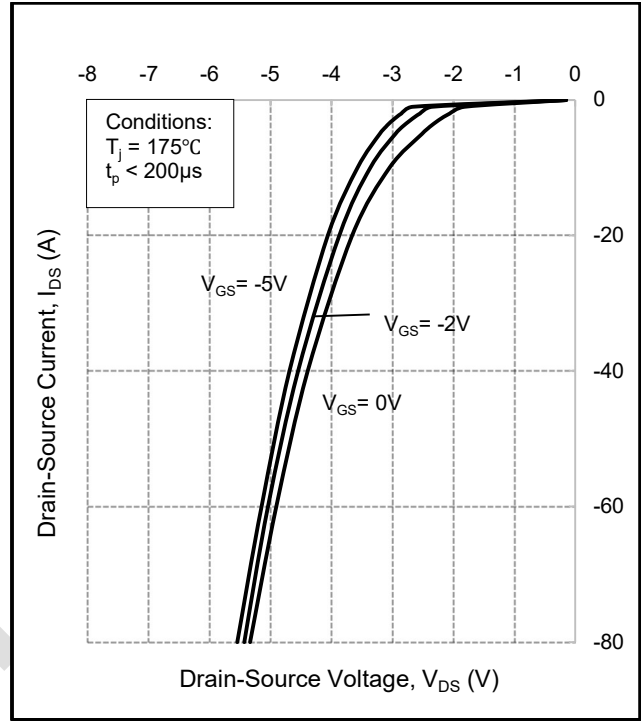

Figure 10. Body diode characteristic at $T_j = 175^\circ\text{C}$

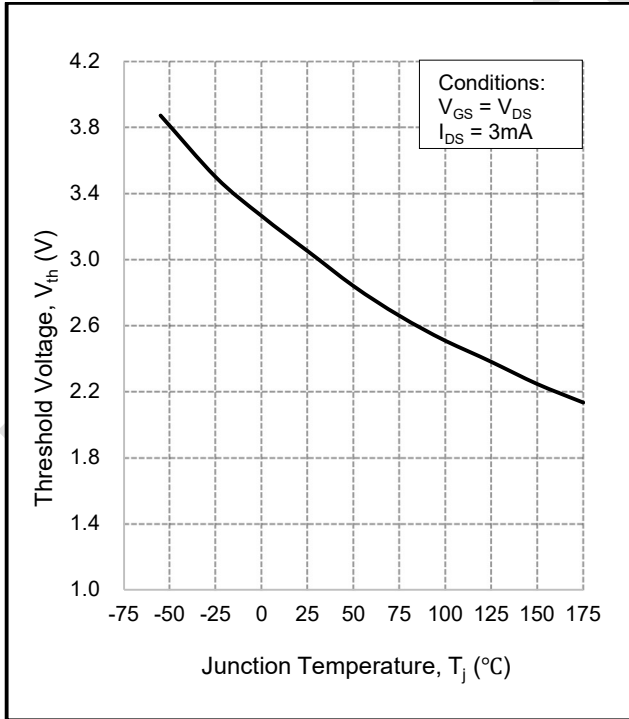

Figure 11. Threshold voltage vs. temperature

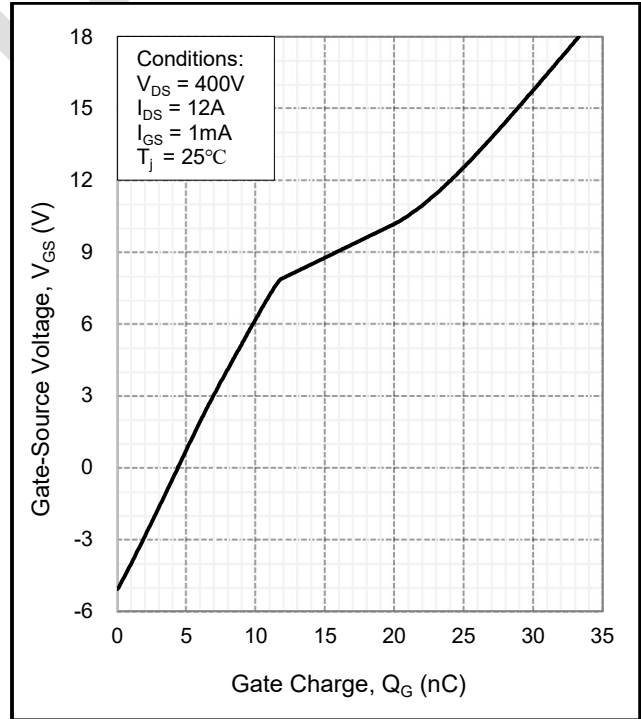

Figure 12. Gate charge characteristics

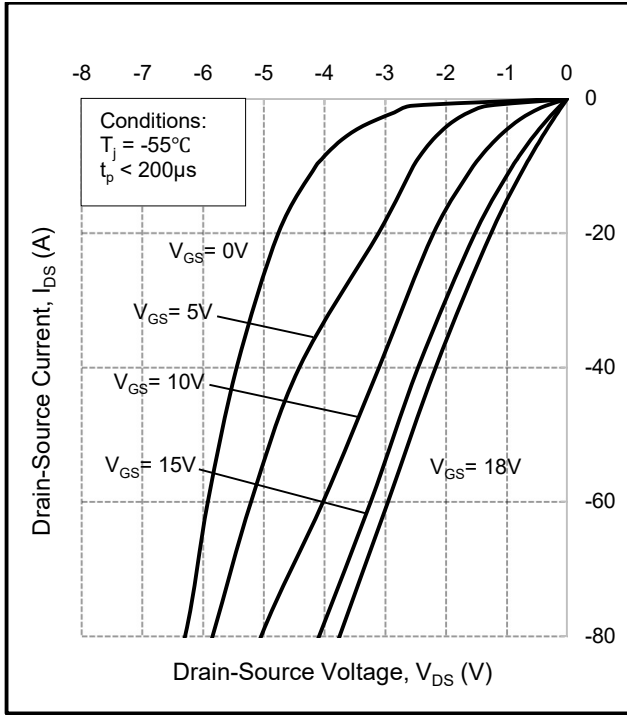

Figure 13. 3rd quadrant characteristic
at $T_j = -55^\circ\text{C}$

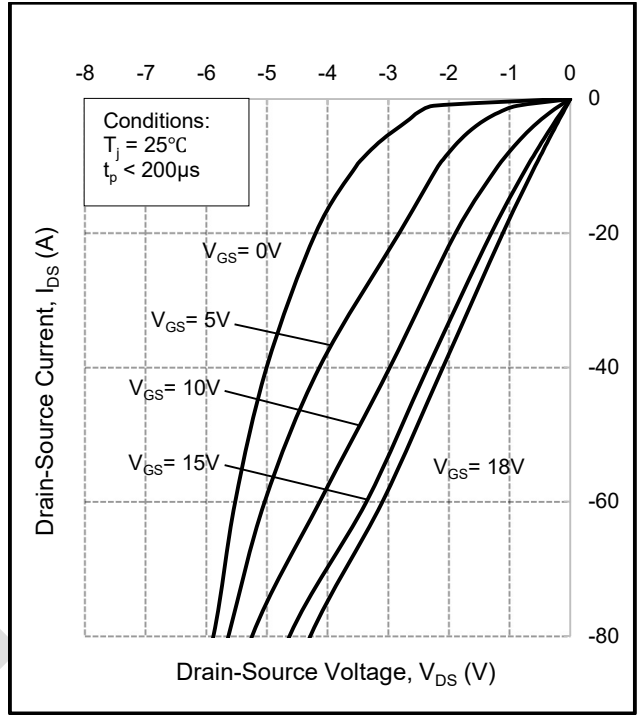

Figure 14. 3rd quadrant characteristic
at $T_j = 25^\circ\text{C}$

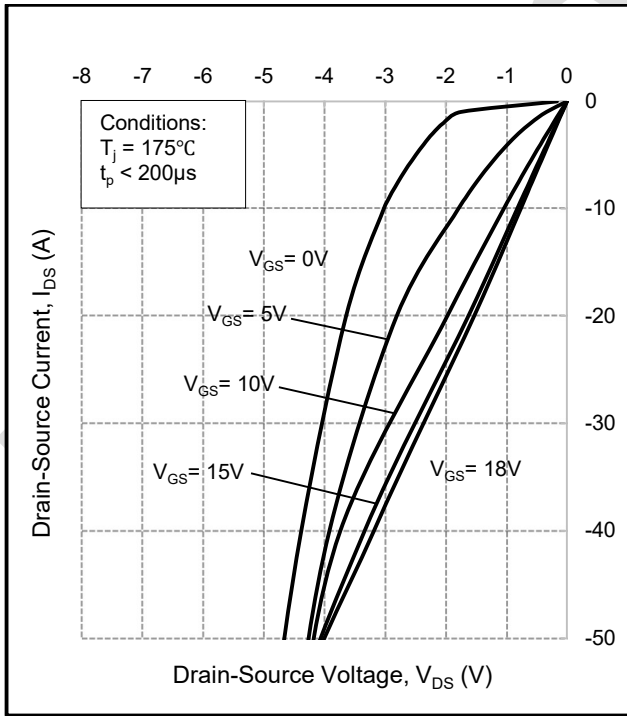

Figure 15. 3rd quadrant characteristic
at $T_j = 175^\circ\text{C}$

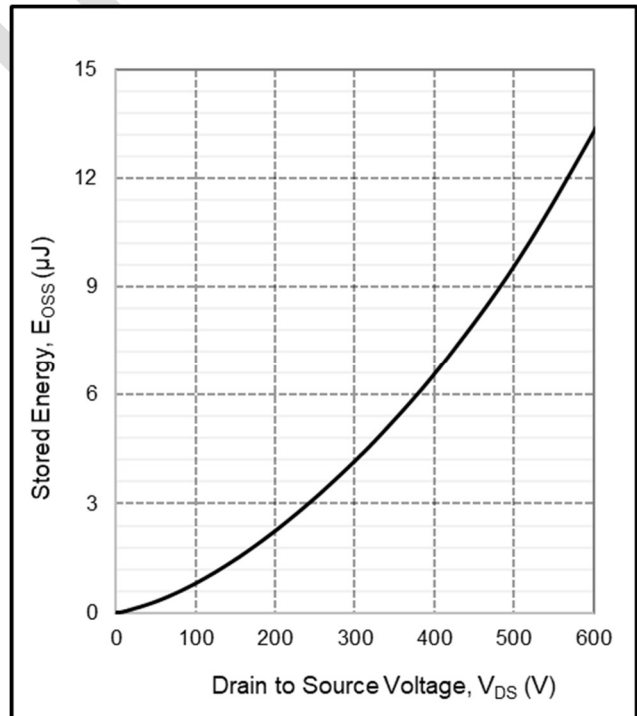

Figure 16. Output capacitor stored energy

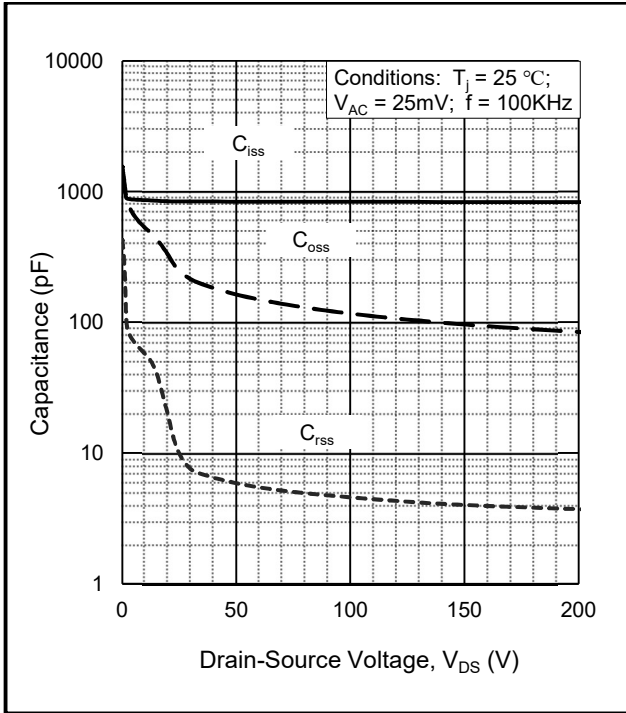

Figure 17. Capacitance vs. drain-source voltage
(0 - 200V)

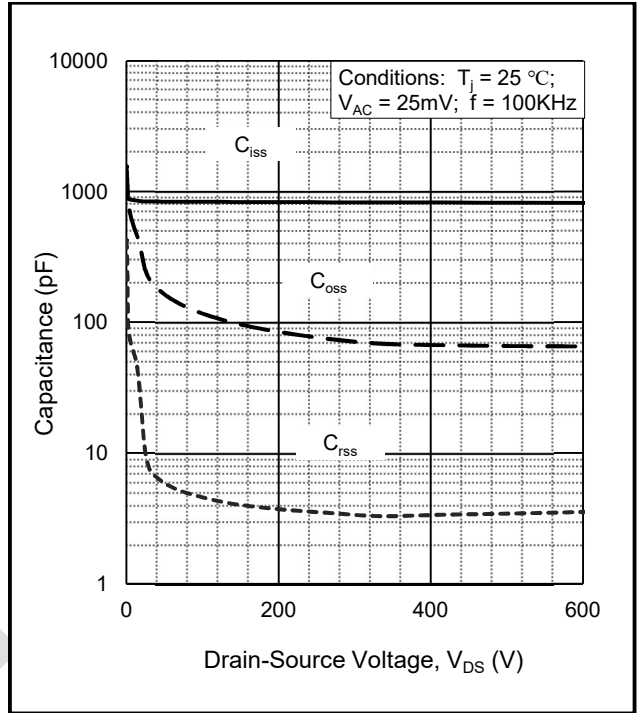

Figure 18. Capacitance vs. drain-source voltage
(0 - 600V)

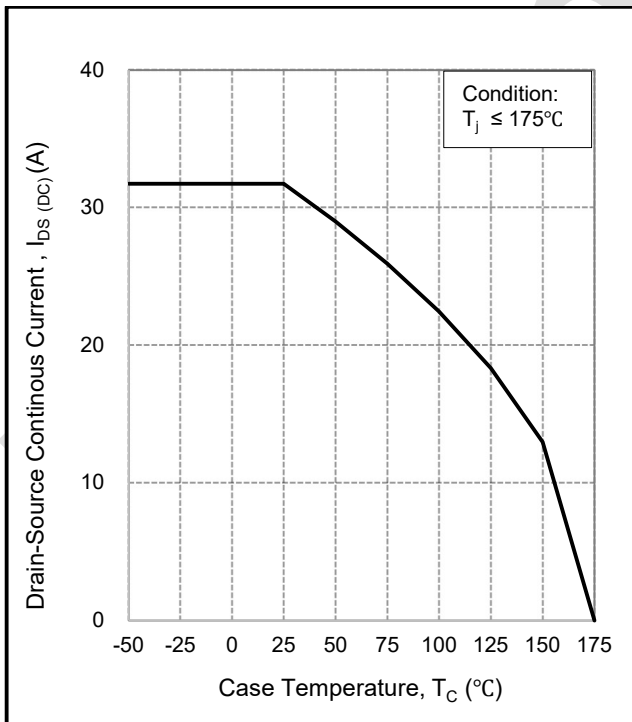

Figure 19. Continuous drain current derating
vs. temperature

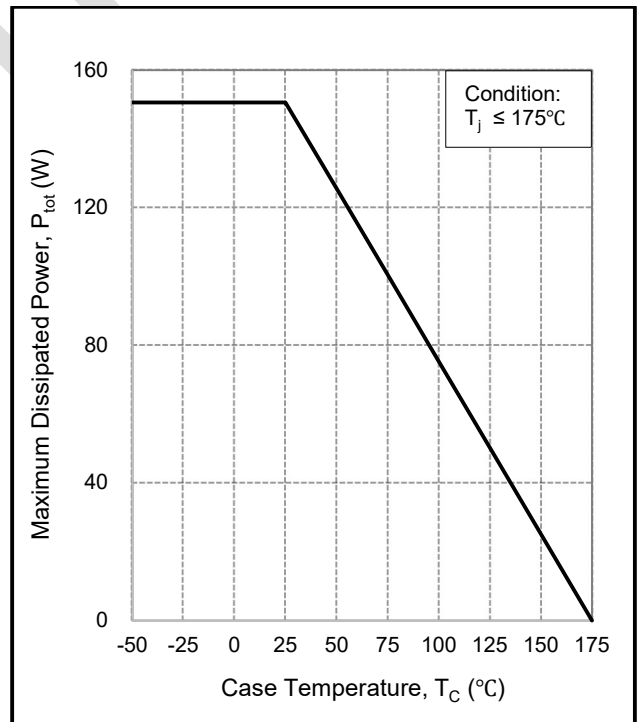

Figure 20. Maximum power dissipation derating
vs. temperature

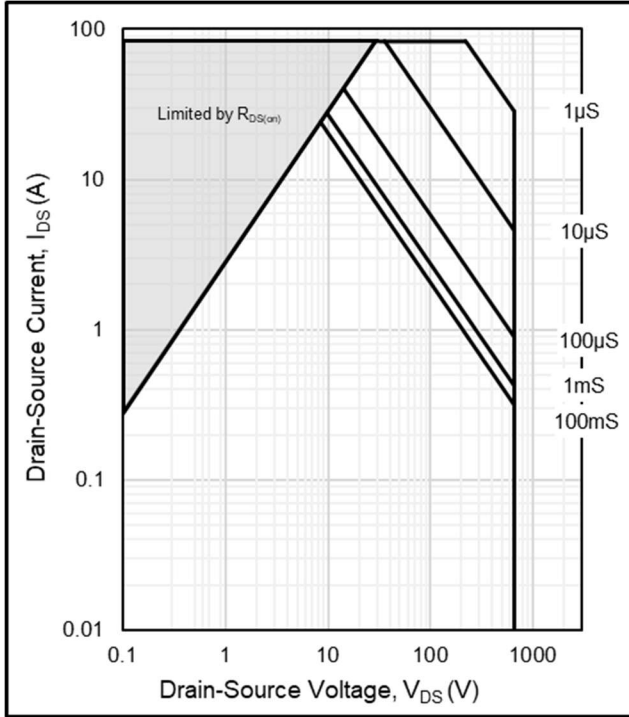

Figure 21. Safe Operating Area

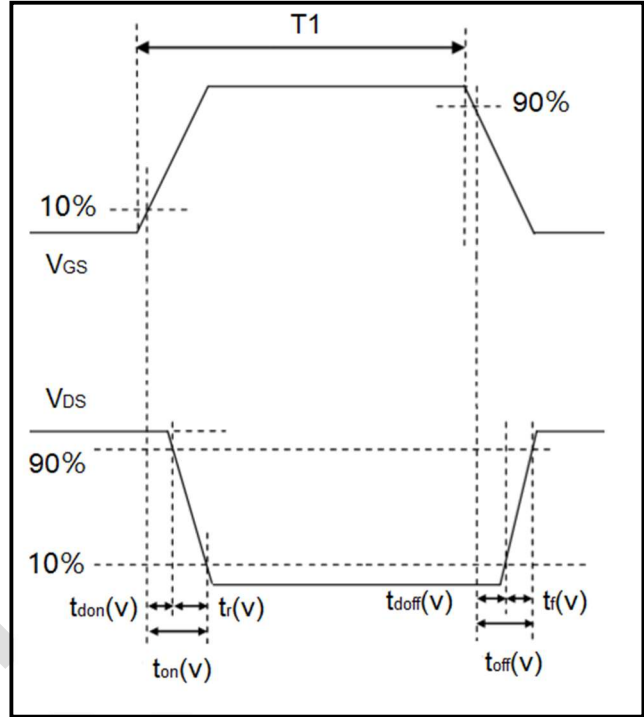

Figure 22. Switching times definition

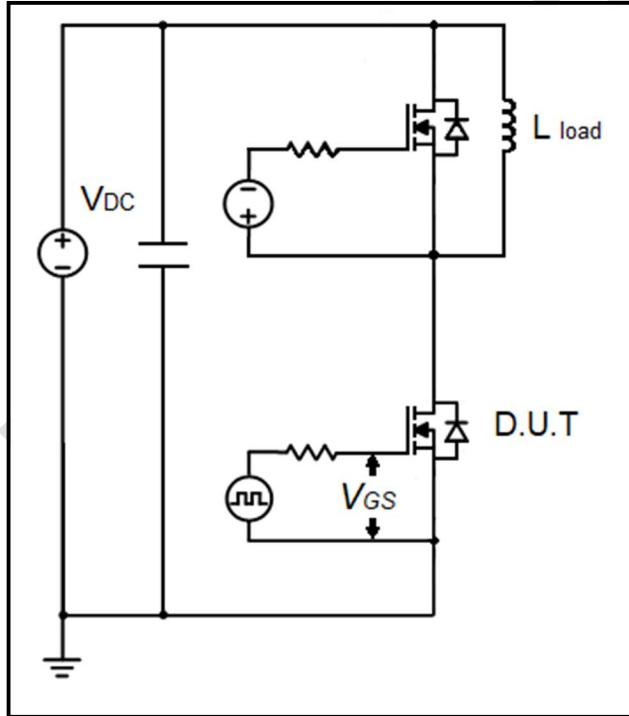

Figure 23. Clamped inductive switching waveform test circuit

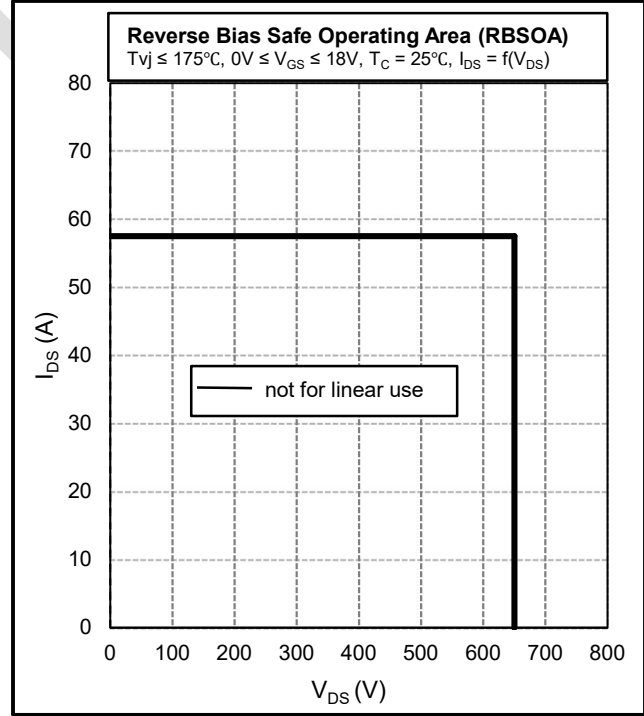
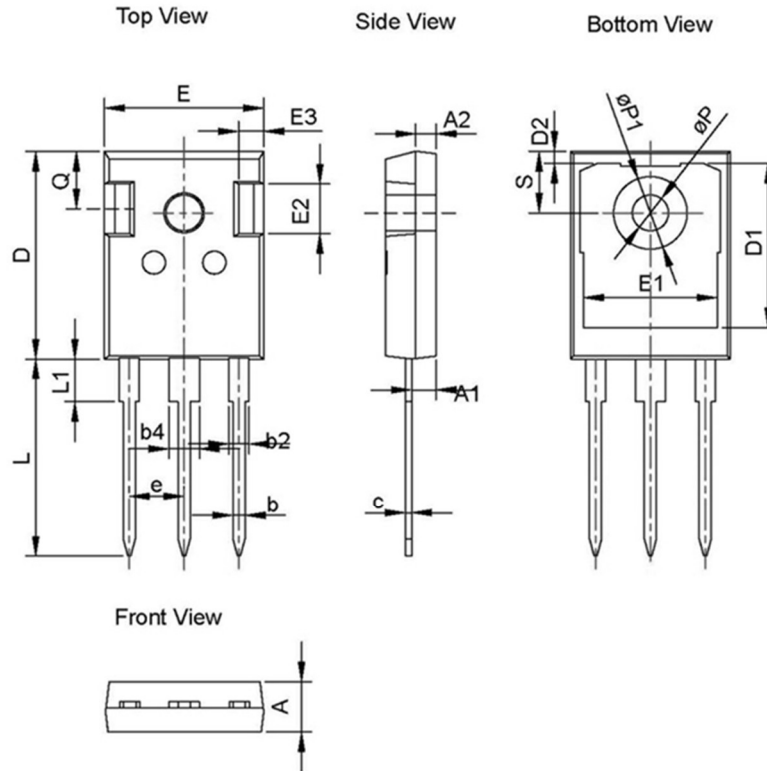

Figure 24. Reverse Bias Safe Operating Area

Package Information:



Dimension unit: [mm]			
Symbol	Min	Nom	Max
A	4.80	5.00	5.20
A1	2.21	2.41	2.61
A2	1.85	2.00	2.15
b	1.11	1.21	1.36
b2	1.91	2.01	2.21
b4	2.91	3.01	3.21
c	0.51	0.60	0.75
D	20.70	21.00	21.30
D1	16.25	16.55	16.85
D2	1.00	1.20	1.35
E	15.50	15.80	16.10
E1	13.00	13.30	13.60
E2	4.80	5.00	5.20
E3	2.30	2.50	2.70
e	5.44 BSC		
L	19.62	19.92	20.22
L1	-	-	4.30
ϕP	3.40	3.60	3.80
$\phi P1$	-	-	7.30
Q	5.40	5.80	6.20
S	6.20 BSC		

Recommended Solder Pad Layout

Note: All dimensions are in mm

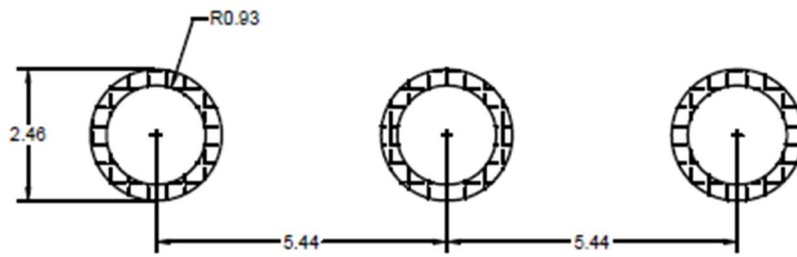

TO-247-3L

Ordering Information

Part number	AMR065V065E2i
Package	TO-247-3L
Unit quantity	300 EA
Packing type	Tube

For more information, visit <https://www.apowerc2.com>