

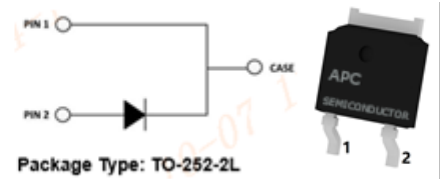

## High Power SiC Schottky Barrier Diode ASA008V065F4



### Applications:

- Industrial power supplies: Industrial UPS
- Battery chargers
- Solar inverters
- Switch mode power supplies

### Features:

- Revolutionary semiconductor material - Silicon Carbide (SiC)
- No reverse recovery
- High-speed switching performance
- System cost / size saving due to reduced cooling requirement
- Junction Temp range -55°C to 175°C

### Absolute Maximum Ratings (T<sub>amb</sub>=25°C, unless specified otherwise)

Symbol	Parameter		ASA008V065F4	Unit
V <sub>DC</sub>	DC reverse voltage		650	V
V <sub>R</sub> RM	Repetitive peak reverse voltage			
V <sub>R</sub> SM	Surge peak reverse voltage			
I <sub>F</sub>	Continuous Forward Current	T <sub>C</sub> = 25°C	24	A
		T <sub>C</sub> = 135°C	12	
		T <sub>C</sub> = 155°C	8	
I <sub>F</sub> SM	Surge non-repetitive forward current	T <sub>C</sub> = 25°C, t <sub>p</sub> = 10ms, half sine pulse	56	
		T <sub>C</sub> = 150°C, t <sub>p</sub> = 10ms, half sine pulse	47	
I <sub>F</sub> Max	Non-repetitive peak forward current	T <sub>C</sub> = 25°C, t <sub>p</sub> = 10μs, pulse	416	
I <sub>F</sub> RM	Surge repetitive forward current	T <sub>C</sub> = 25°C, t <sub>p</sub> = 10ms, half sine wave D = 0.1	30	
P <sub>tot</sub>	Total Power Dissipation		95	W
∫i <sup>2</sup> dt	i <sup>2</sup> t value		15.7	A <sup>2</sup> s
T <sub>j</sub>	Operating junction temperature range		-55 to 175	°C
T <sub>stg</sub>	Storage temperature range		-55 to 175	
M	Mounting torque	M3 screw	1	Nm

**Static Electrical Characteristics ( $T_A = 25^\circ\text{C}$ , unless specified otherwise)**

Symbol	Parameter	Test Conditions	Min	Typ	Max	Unit
$V_{DC}$	DC blocking voltage	$I_R = 100 \mu\text{A}$	650	-	-	V
$V_F$	Forward voltage	$I_F = 8\text{A}, T_j = 25^\circ\text{C}$	-	1.27	1.45	V
		$I_F = 8\text{A}, T_j = 175^\circ\text{C}$	-	1.45	1.70	
$I_R$	Reverse current	$V_R = 650\text{V}, T_j = 25^\circ\text{C}$	-	4	48	$\mu\text{A}$
		$V_R = 650\text{V}, T_j = 175^\circ\text{C}$	-	15	192	

**Thermal Characteristics**

Symbol	Parameter	Test conditions	Min	Typ	Max	Unit
$R_{\theta JC}$	Junction-to-case Thermal Resistance		-	1.58	-	$^\circ\text{C}/\text{W}$

**Dynamic Characteristics ( $T_A = 25^\circ\text{C}$ , unless specified otherwise)**

$C$	Total capacitance	$V_R = 0\text{V}, f = 1\text{MHz}$	-	462	-	$\text{pF}$
		$V_R = 200\text{V}, f = 1\text{MHz}$	-	41	-	
		$V_R = 400\text{V}, f = 1\text{MHz}$	-	32	-	
$Q_C$	Total capacitive charge	$V_R = 400\text{V}$	-	21	-	nC
$E_C$	Capacitance stored energy	$V_R = 400\text{V}$	-	3.1	-	$\mu\text{J}$

### Electrical Characteristic Diagrams

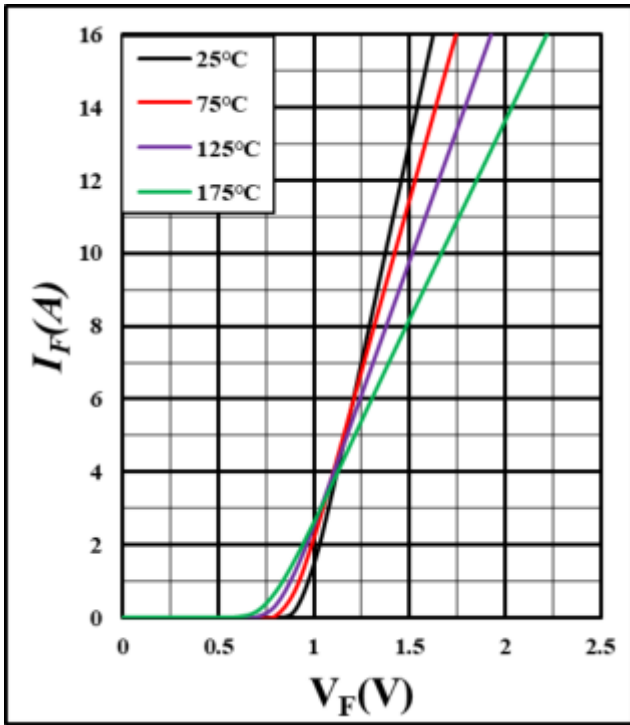

Figure 1. Forward characteristics

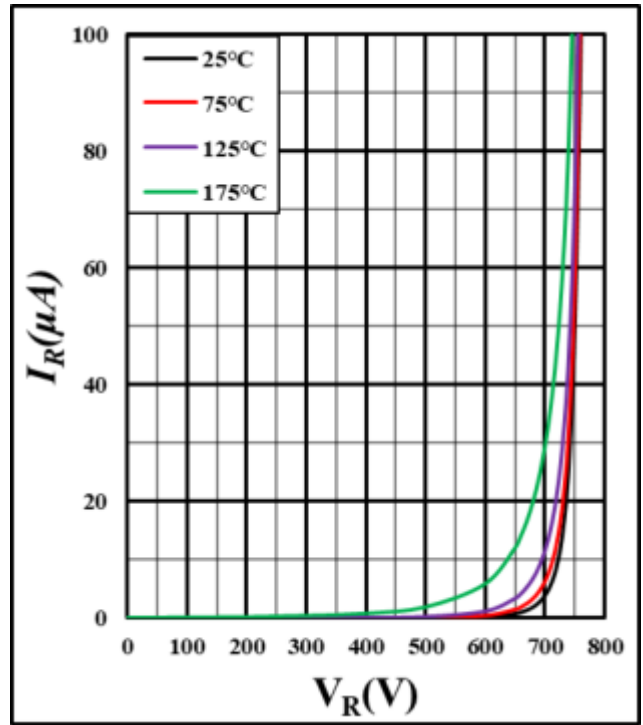

Figure 2. Reverse characteristics

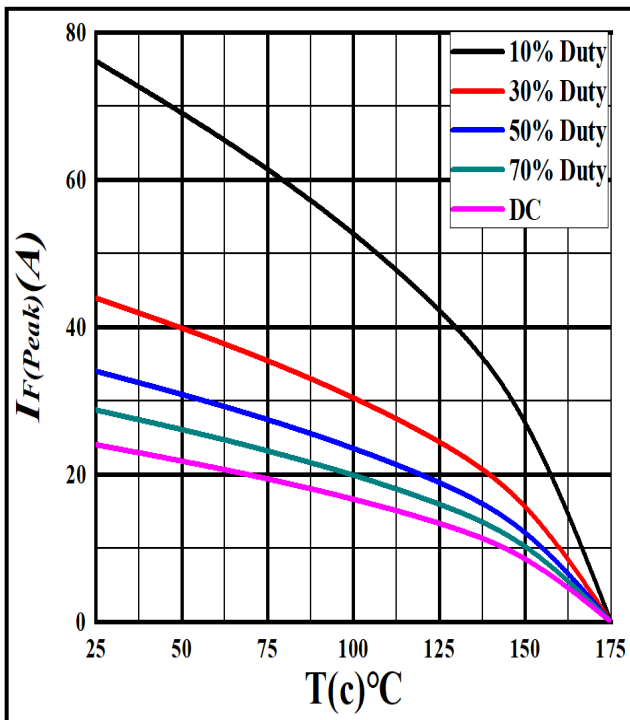

Figure 3. Current derating

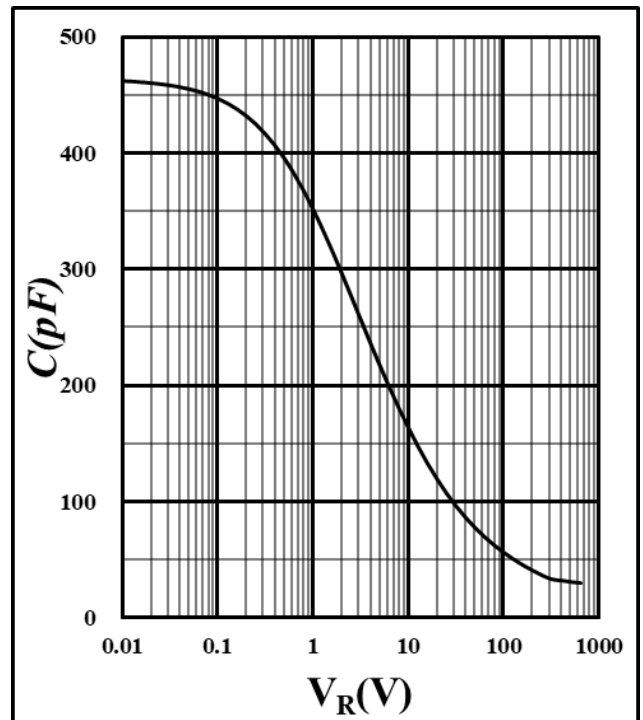

Figure 4. Capacitance vs. reverse voltage

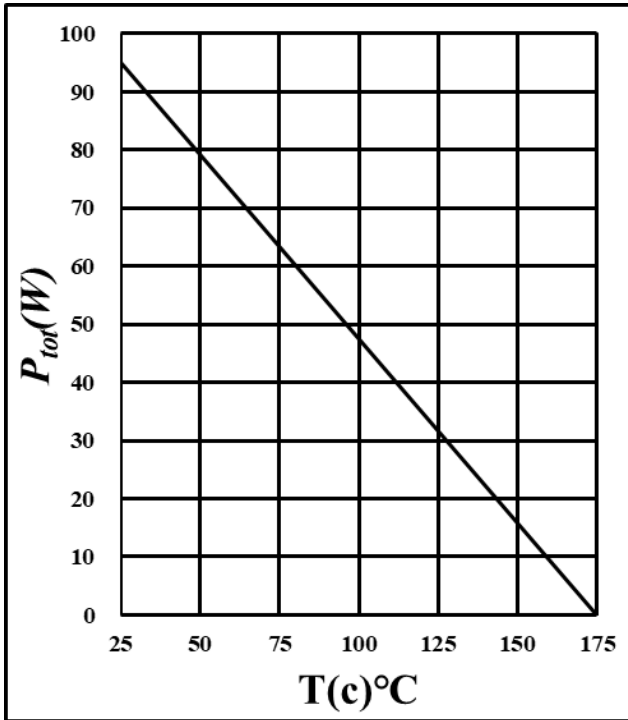

Figure 5. Power derating

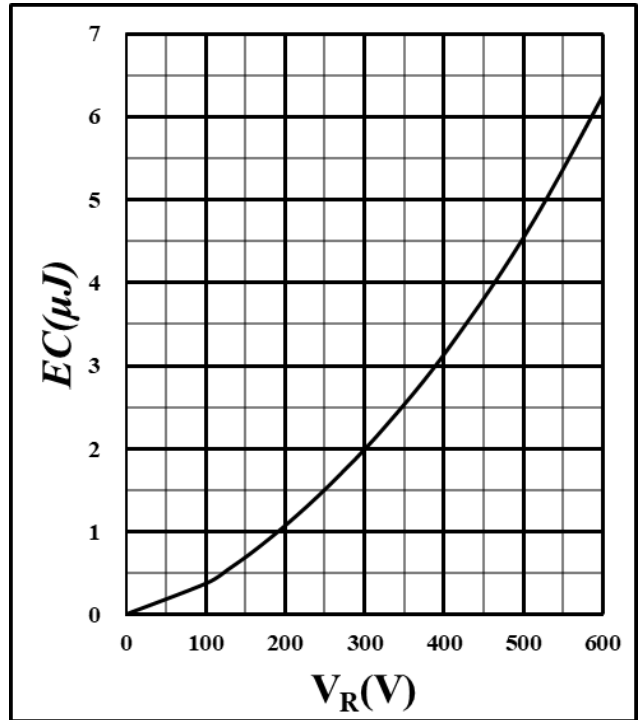

Figure 6. Capacitance stored energy

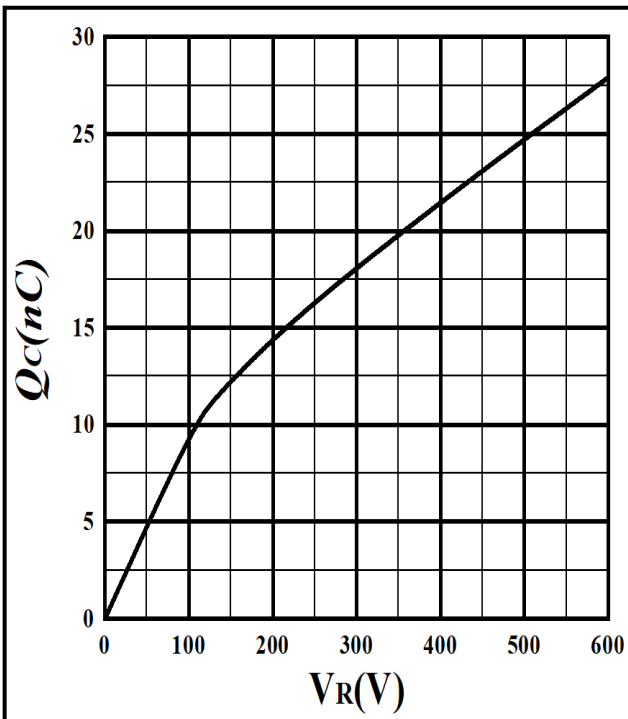

Figure 7. Total capacitance charge vs. reverse voltage

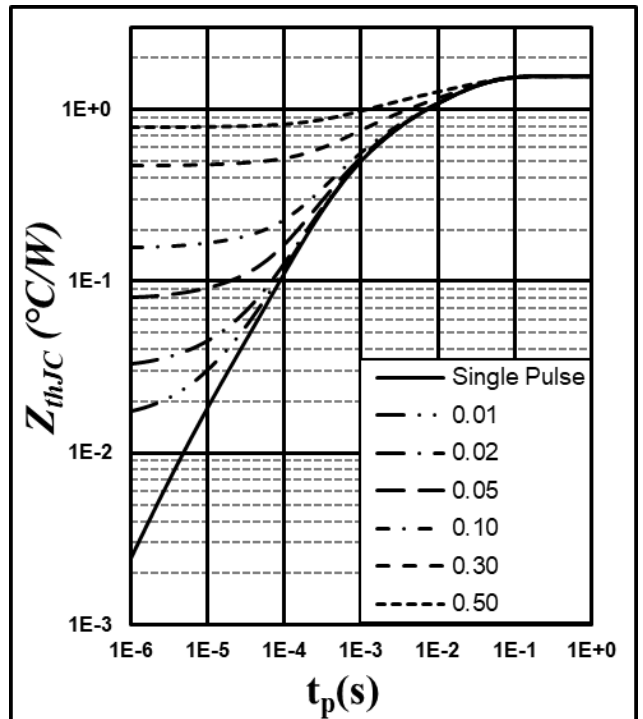
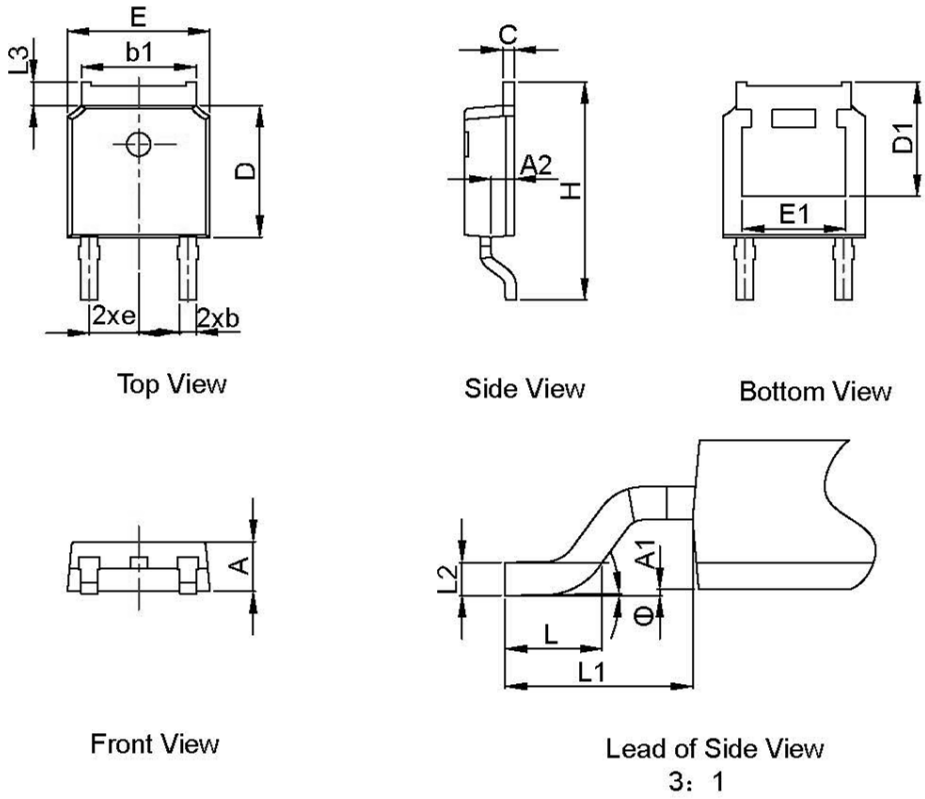

Figure 8. Transient Thermal Impedance  
 (Junction - Case)

**Package Information**



Dimension unit: [mm]			
Symbol	Min	Nom	Max
A	2.20	2.30	2.38
A1	0	-	0.127
A2	0.97	1.07	1.17
b	0.68	0.78	0.90
b1	5.20	5.33	5.46
c	0.43	0.53	0.61
D	5.98	6.10	6.22
D1	5.30 REF		
E	6.40	6.60	6.73
E1	4.63	-	-
e	2.286 BSC		
H	9.40	10.10	10.50
L	1.38	1.50	1.75
L1	2.743 REF		
L2	0.51 BSC		
L3	0.88	-	1.28
$\theta$	0°	-	8°

## Recommended Solder Pad Layout

Note: All dimensions are in mm

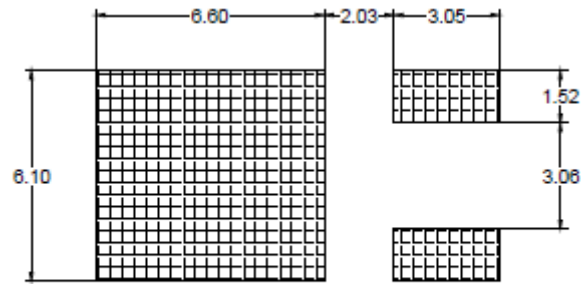

TO-252-2L

## Ordering Information

Part number	ASA008V065F4
Package	TO-252-2L
Unit quantity	2500 EA
Packing type	Tape & Reel

For more information, visit <https://www.apowerc2.com>