

CFT-50X-R

Red LED

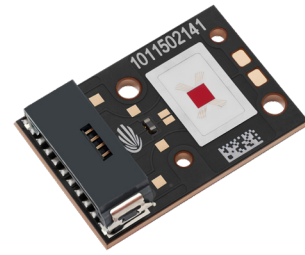

Features

- Monolithic electrically isolated Red LED with 5 mm² emitting area for optimal coupling into 2-4 mm diameter fiber bundles
- Typical peak wavelength emission of 632 nm
- Comprehensive product line spanning the entire visible range in the same package platform
- High drive current operation: up to 15 A under CW conditions and 25 A under pulse conditions
- Windowless package improves coupling-efficiency into fiber optics
- Excellent peak wavelength stability with current and temperature across the spectrum



Applications

- Fiber-coupled Illumination
- Life-science/ Biomedical
- Fluorescence microscopy
- Machine Vision
- Industrial Lighting
- Light engines

Table of Contents

Ordering Information.	2
Binning Structure.	3
Absolute Maximum Ratings	4
Device Characteristics	5
Angular Distribution and Typical Spectrum.	8
Mechanical Dimensions.	9
Shipping Tray Outline	10
Shipping Label	11
Notes	12
Revision History	13



Ordering Information

Ordering Part Numbers¹

Color	Radiometric flux		Wavelength Bins	Ordering Part Number
	Min. Power Bin	Min. Power		
Red	F	7.0 W	626, 632	CFT-50X-R-L42-F100

Part Number Nomenclature

CFT	50X	R	L42	<Bin kit>
Product Family	Chip Area	Color	Package Configuration	Bin Kit
CFT: Copper-core PCB, no encapsulation	50X: 5.0 mm ²	R: Red	Internal package code	Refer to ordering part numbers in this document

Note

1. Flux Bin listed is minimum bin shipped, higher bins may be included at Luminus' discretion.



Binning Structure

Flux Bins^{1,2}

Color	Radiometric Flux Bin ³	Binning @ 15 A, T _c = 25°C ⁴	
		Minimum Power (W)	Maximum Power (W)
Red	F	7.0	7.5
	G	7.5	8
	H	8	8.75
	J	8.75	9.5
	K	9.5	10.25

Peak Wavelength Bins²

Color	Wavelength Bin ³	Binning @ 15 A, T _c = 25°C ⁴	
		Minimum Wavelength (nm)	Maximum Wavelength (nm)
Red	626	626	632
	632	632	638

Note:

1. Luminus maintains a +/- 6% tolerance on flux measurements.
2. Products are production tested then sorted and packed by bin.
3. Individual bins are not orderable. Please refer to the Product Ordering information page for a list of orderable bin kits.
4. Product test condition: 15 A, 20 ms single pulse, 25°C case temperature.



Absolute Maximum Ratings

	Symbol	Values	Unit
Minimum Forward Current (CW or Pulsed) ¹	$I_{f \min}$	0.2	A
Maximum Forward Current (CW) ²	$I_{f \text{ CW max}}$	15	
Maximum Forward Current (Pulsed) ² (duty cycle < 50%)	$I_{f \text{ Pulsed max}}$	25	
Forward Surge Current (Pulsed) ² (Frequency >240Hz, duty cycle <10%, t=1ms)	$I_{\text{surge max}}$	30	A
Storage Temperature		100	°C
Junction Temperature ²	$T_{j \text{ max}}$	125	°C

Note:

1. For reference only.
2. CFT-50X-R LED is designed for operation at current up to 15 A under CW conditions, 25 A under pulse conditions and temperature as specified above. Product lifetime data is specified at recommended forward drive currents. Sustained operation at or beyond absolute maximum currents or temperatures will result in a reduction of device lifetime compared to recommended conditions. Refer to the lifetime derating curves for further information.



Device Characteristics^{1,2,3}

Optical and Electrical Characteristics	Symbol	Value	Unit
Emitting Area	A_E	4.91	mm ²
Emitting Area Dimension		2.215 x 2.215	mm x mm
Test Peak Drive Current	I_f	15	A
Peak Luminous Flux ^{4,5,6}	Φ_V	1550	lm
Peak Radiometric Flux ^{4,5,6}	Φ_E	8.0	W
Forward Voltage	V_{fmin}	2.6	V
	V_f	3.2	
	V_{fmax}	3.8	
Dominant Wavelength ⁴	λ_d	622	nm
Peak Wavelength ⁴	λ_p	632	nm
FWHM- Spectral bandwidth at 50% of Φ_V	$\Delta\lambda_{1/2}$	20	nm
Chromaticity Coordinates ⁷	CIE x	0.695	
	CIE y	0.304	
Thermal Characteristics			
Thermal Resistance (junction to case) ⁸	$R_{\theta j-c real}$	0.75	°C/W
Thermal Resistance at WPE = 18% (junction to case) ^{8,9}	$R_{\theta j-c elec}$	0.62	°C/W
Thermal Resistance at WPE = 18% (junction to thermistor) ^{8,9}	$R_{\theta j-ref elec}$	0.74	°C/W
Thermal Coefficient of Photometric Flux		-0.9	%/°C
Thermal Coefficient of Radiometric Flux		-0.6	%/°C
Forward Voltage Temperature Coefficient		-2.0	mV/°C

Note:

- All ratings are based on operation with a constant case temperature $T_c = 25^\circ\text{C}$.
- CFT-50X-R device can be driven at currents ranging from 200 mA to 25 A and at duty cycles ranging from 1% to 100%. Drive current and duty cycle should be adjusted as necessary to maintain the junction temperature desired to meet application lifetime requirements.
- Tested at Current of 15 A, 20 ms single pulse.
- Unless otherwise noted, values listed are typical. Devices are production tested and specified at 15 A.
- Total flux from emitting area at listed peak wavelength. Reported performance is included to show trends for a selected power level. For specific minimum and maximum values, use bin tables. For product roadmap and future performance of devices, contact Luminus.
- Caution must be taken not to stare at the light emitted from these LEDs. Under special circumstances, the high intensity could damage the eye.
- In CIE 1931 chromaticity diagram coordinates, normalized to $X+Y+Z=1$.
- Measurements are in accordance with JEDEC 51-14.
- $R_{\theta j-ref}$ is measured on a water-cooled stage with e-graf as the thermal interface material. $R_{\theta j-ref}$ is system-dependent. For instructions on how to calculate $R_{\theta j-ref}$ for your specific system, please refer to application brief https://download.luminus.com/datasheets/Luminus-White-Paper-Thermal-Mgmt_Thermistors.pdf



Relative Radiometric Flux-Single Pulse Mode

Forward current: $\phi_v/\phi_v(15\text{ A})$ Single Pulse 20 ms, $T_c = 25^\circ\text{C}$

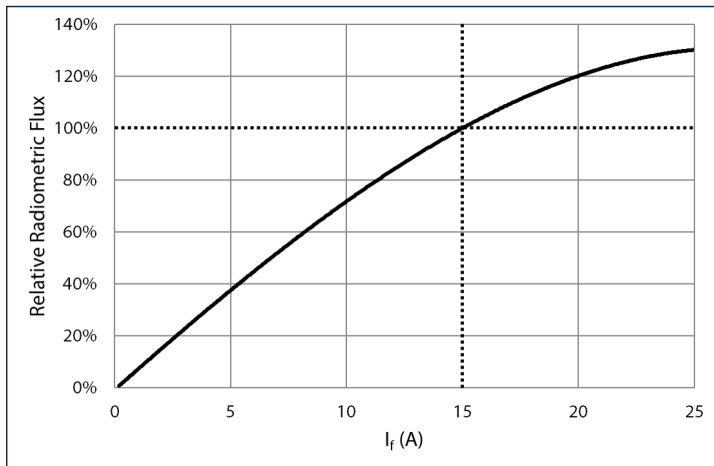

Temperature: $\phi_v/\phi_v(25^\circ\text{C})$ Single Pulse 20 ms, $I_f = 15\text{ A}$

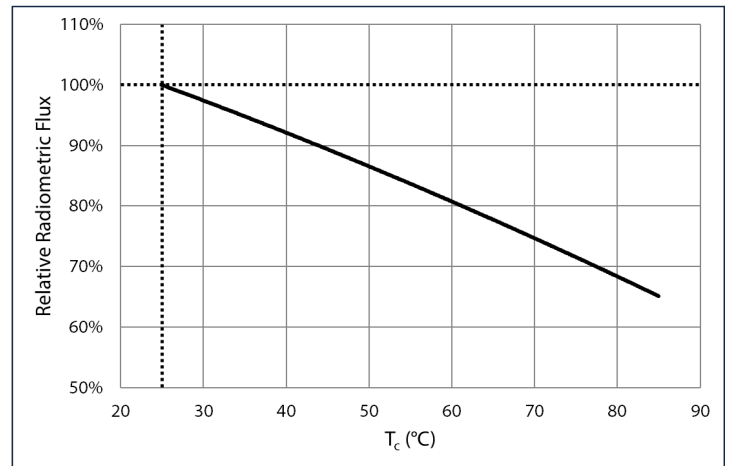

Forward Voltage-Single Pulse Mode

Forward current: $\Delta V_f = V_f(I_f) - V_f(15\text{ A})$ Single Pulse 20 ms, $T_c = 25^\circ\text{C}$

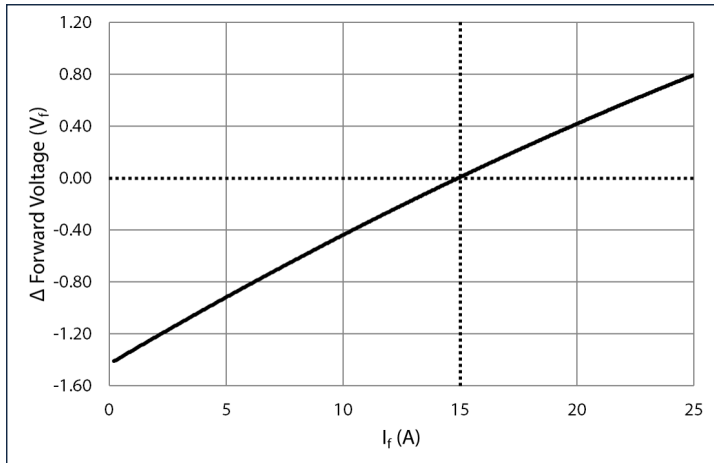

Temperature: $\Delta V_f = V(T_c) - V(25^\circ\text{C})$ Single Pulse 20 ms, $I_f = 15\text{ A}$

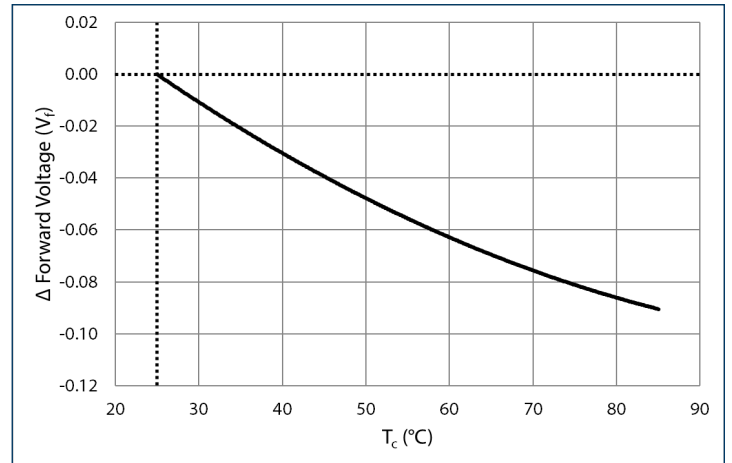

Peak Wavelength Shift-Single Pulse Mode

Forward current: $\Delta \lambda_d = \lambda_d(I_f) - \lambda_d(15\text{ A})$ Single Pulse 20 ms, $T_c = 25^\circ\text{C}$

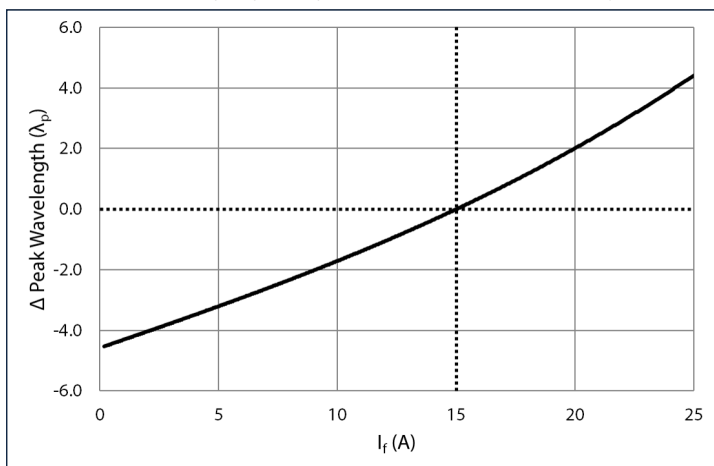

Temperature: $\Delta \lambda_d = \lambda_d(T_c) - \lambda_d(25^\circ\text{C})$ Single Pulse 20 ms, $I_f = 15\text{ A}$

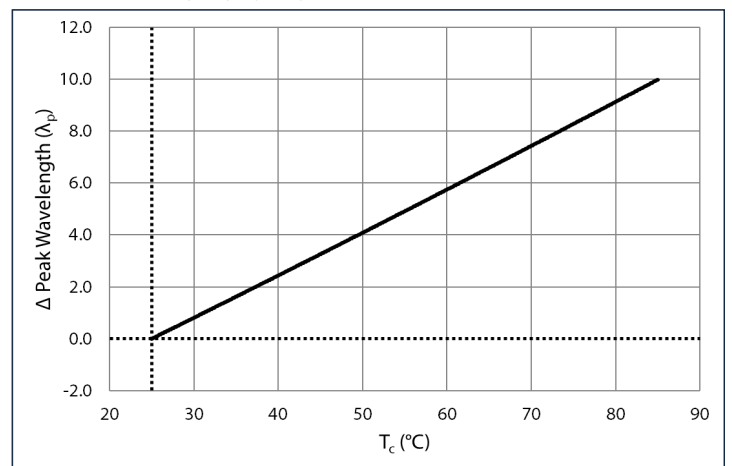



Relative Radiometric Flux-CW Mode

Forward current: $\phi_f/\phi_f(15\text{ A})$ CW, $T_c = 40^\circ\text{C}$

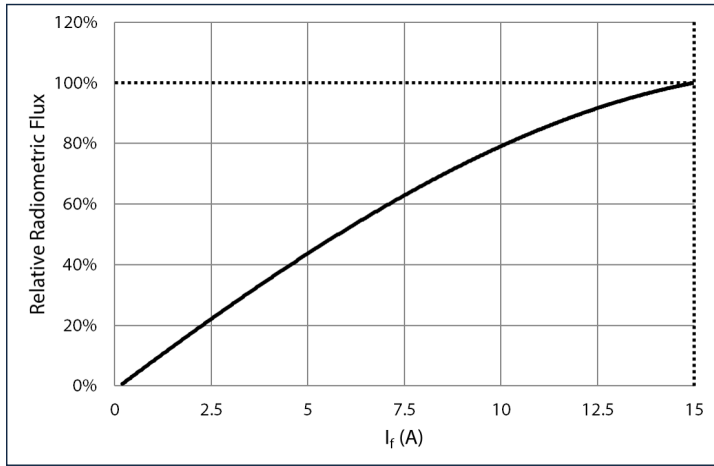

Temperature: $\phi_f/\phi_f(40^\circ\text{C})$ CW, $I_f = 15\text{ A}$

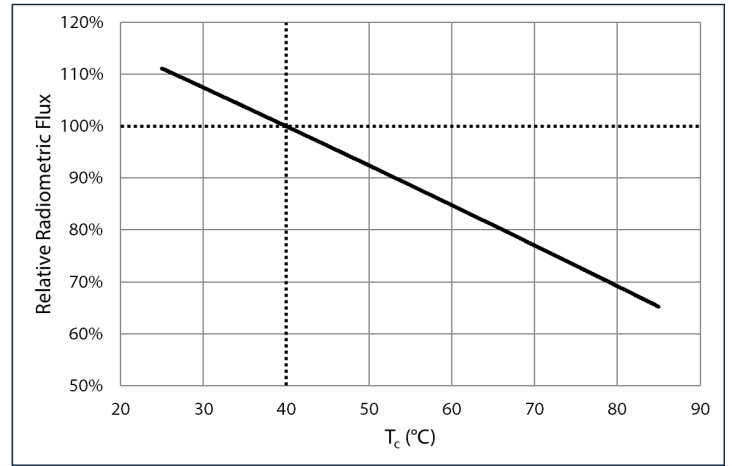

Forward Voltage-CW Mode

Forward current: $\Delta V_f = V_f(I_f) - V_f(15\text{ A})$ CW, $T_c = 40^\circ\text{C}$

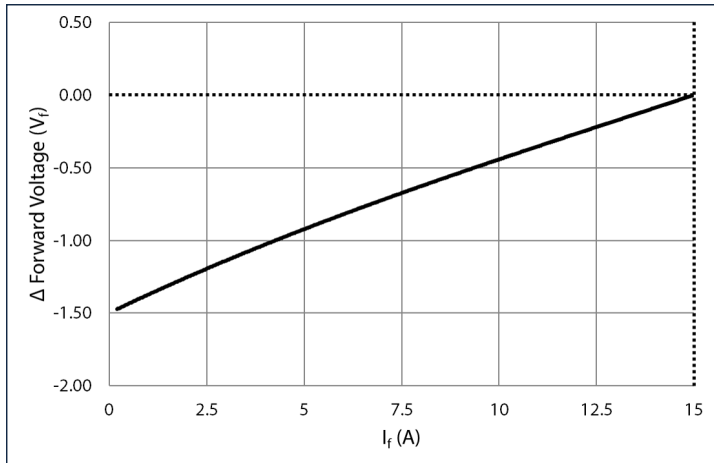

Temperature: $\Delta V_f = V(T_c) - V(40^\circ\text{C})$ CW, $I_f = 15\text{ A}$

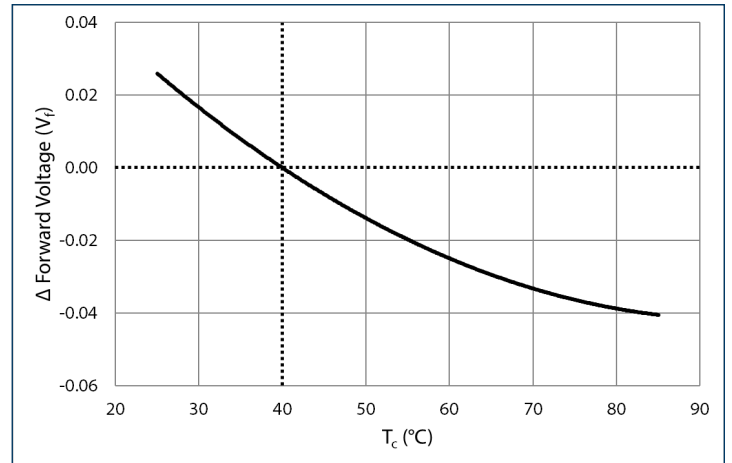

Peak Wavelength Shift-CW Mode

Forward current: $\Delta \lambda_d = \lambda_d(I_f) - \lambda_d(15\text{ A})$ CW, $T_c = 40^\circ\text{C}$

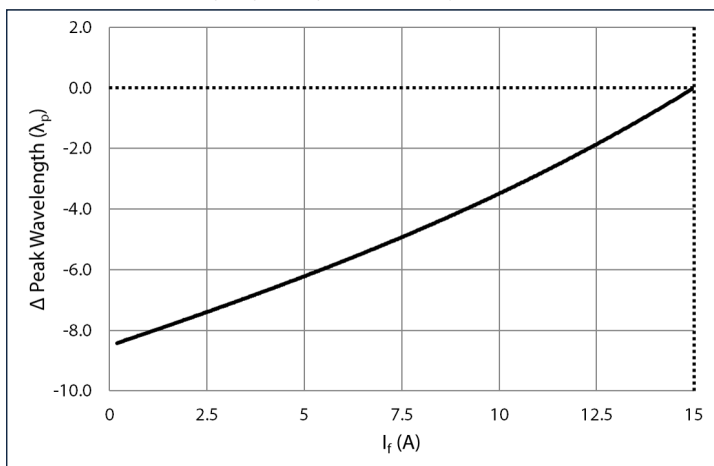

Temperature: $\Delta \lambda_d = \lambda_d(T_c) - \lambda_d(40^\circ\text{C})$ CW, $I_f = 15\text{ A}$

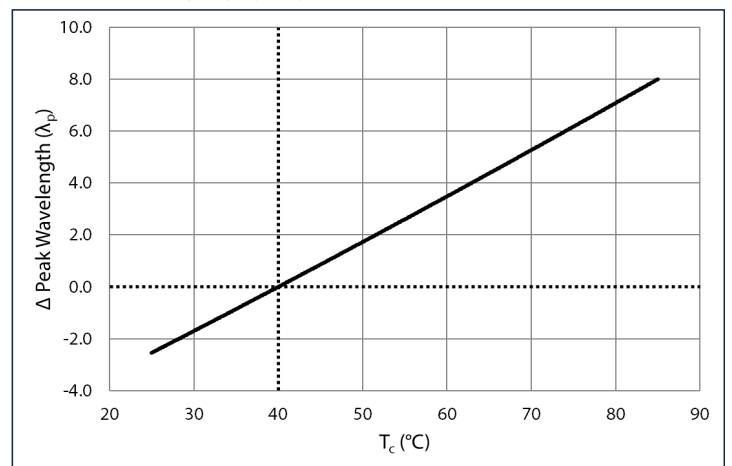



Angular Distribution and Typical Spectrum

Angular Intensity Distribution

$$I_{\text{ref}} = f(\Phi); T_c = 25^\circ\text{C}$$

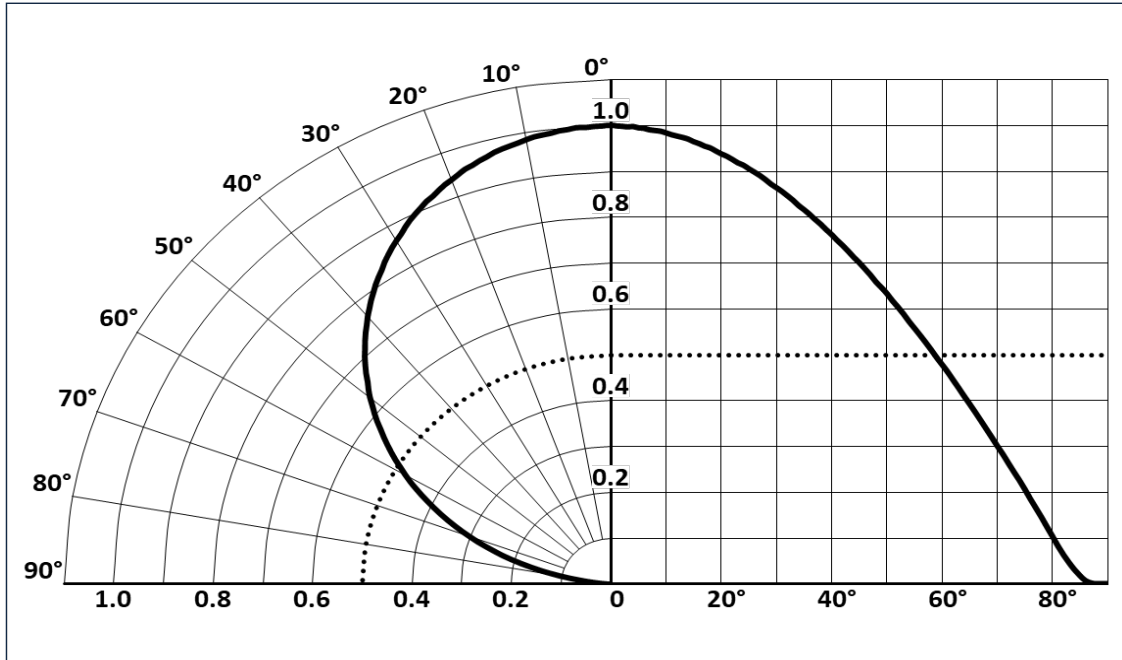

Typical Spectrum

$$\Phi_{\text{ref}} = f(\lambda); I_f = 2.5 \text{ A}; T_c = 25^\circ\text{C}$$

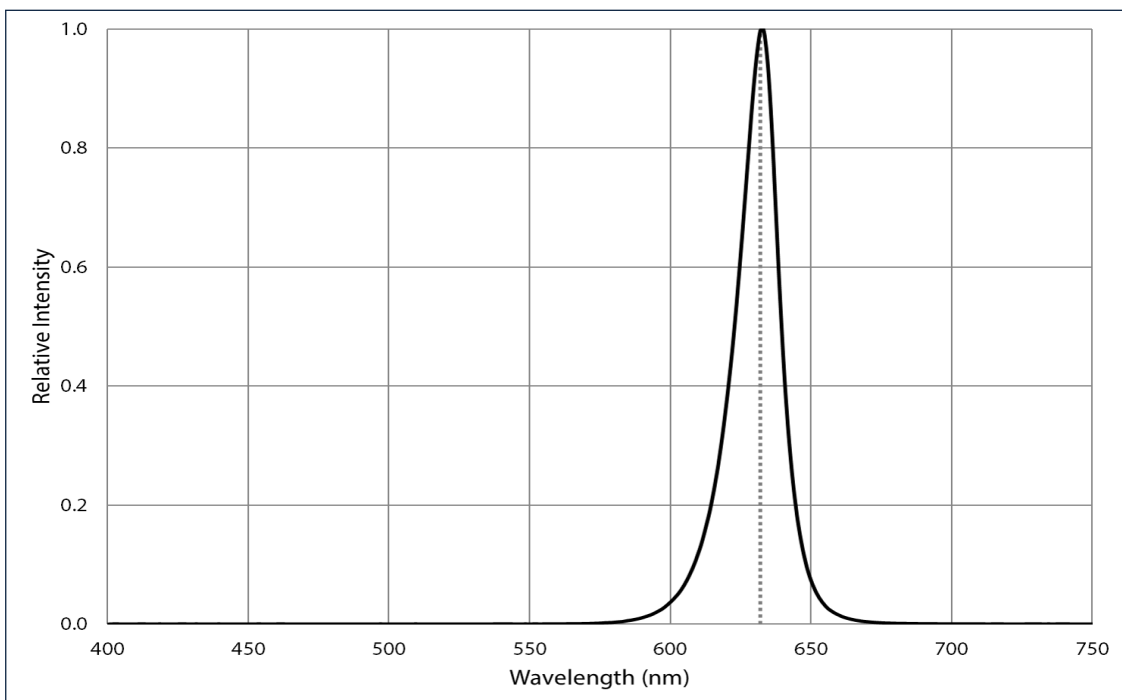

Mechanical Dimensions

DIMENSIONS IN MILLIMETERS

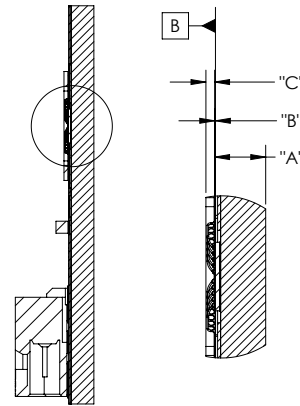
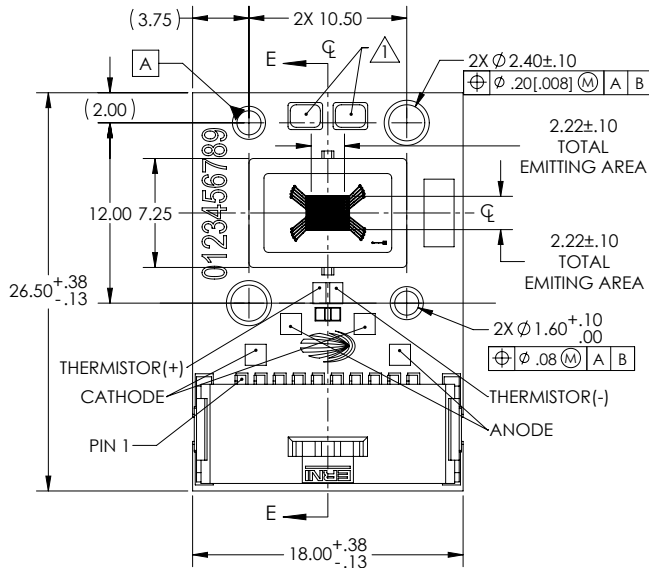
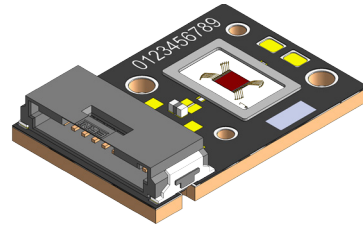

SECTION E-E

NOTES:
 TEST PADS ARE ELECTRICALLY CONNECTED TO THE BOARD COPPER BASE.

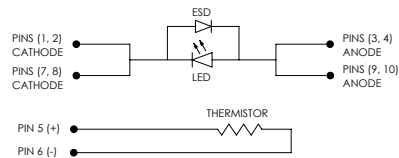

PINS 1, 2, 7, 8 (CATHODE) AND 3, 4, 9, 10 (ANODE) MUST BE POWERED SIMULTANEOUSLY

LED CIRCUIT DIAGRAM

PIN NO(S).	ASSIGNMENT
1,2	CATHODE (-)
3,4	ANODE (+)
5	THERMISTOR (+)
6	THERMISTOR (-)
7,8	CATHODE (-)
9,10	ANODE (+)

DIMENSION NAME	DESCRIPTION	NOMINAL DIMENSION	TOLERANCE
"A"	TOP OF METAL SUBSTRATE (DATUM B) TO BACK OF COREBOARD	1.67	±.10
"B"	TOP OF METAL SUBSTRATE (DATUM B) TO TOP OF EMITTING AREA	.03	±.03
"C"	TOP OF EMITTING AREA TO TOP OF FRAME	.29	±.13

DWG-003255 REV D

- For detailed drawing please refer to DWG-003255 document.
- The CFT-50X-R copper PCB is electrically neutral.
- Mating connector P/N: TE Connectivity (ERNI) 484084-E
- Check NEC standards for ampacity of the power cable being used.
- Recommended wire: MIL-W-16878/6 Type ET or equivalent
- Minimum requirements, manufacturer:
 - Gauge: AWG 22, Type: 7-strand plated copper or solid copper core
 - Maximum Outer Diameter (OD): 1.27 mm
 - Insulation material: PTFE or ETFE required for high-temperature and high-current rating



Shipping Tray Outline

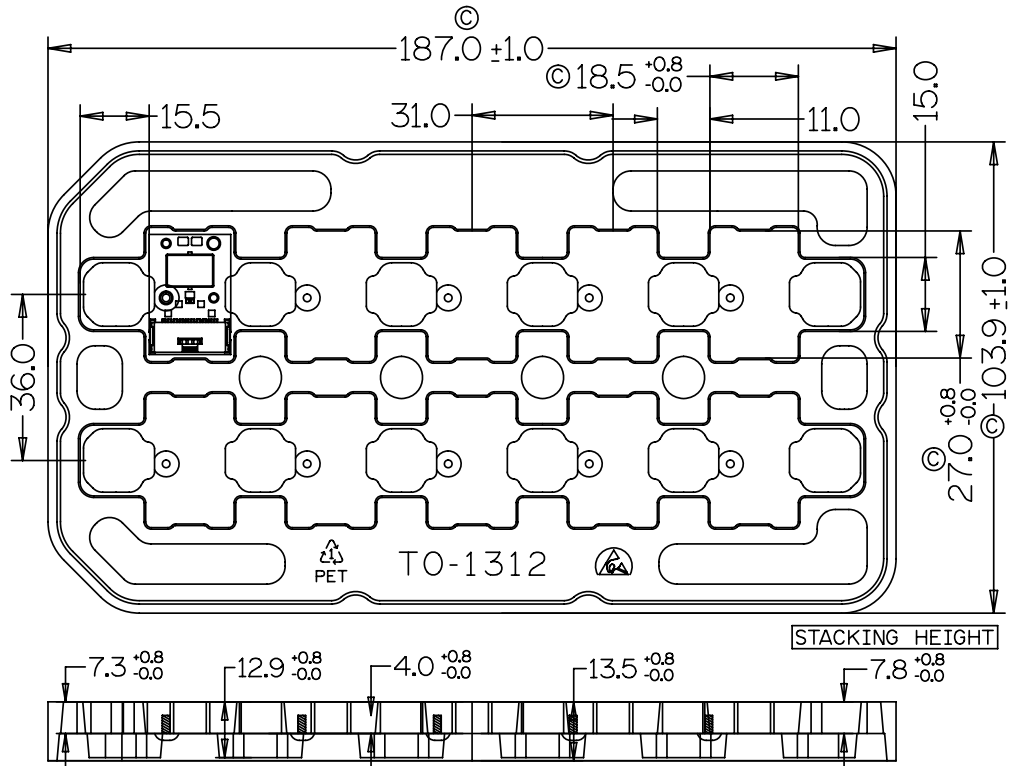

Note:

1. The maximum draft is 5 degrees unless otherwise stated.
2. All radii are to be 1.25 mm unless otherwise stated.
3. The surface resistivity is 10E6 ~ 10E9 Ohm/sq unless otherwise stated.
4. All cells are identical.
5. All dimensions are in millimeters (mm).
6. All numbers with © symbol designate a manufacturing inspection point.
7. All numbers without © symbol are for reference purposes only.
8. The material used is RoHS compliant.



Shipping Label

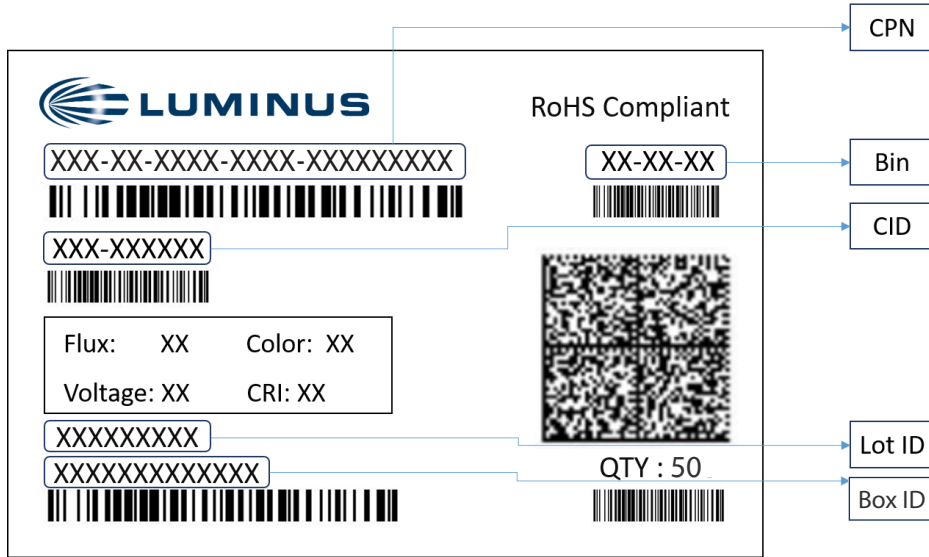

Label Fields:

- CPN: Luminus ordering part number
- CID: Customer's part number
- QTY: Quantity of devices in pack
- Flux: Bin as defined on page 3
- Voltage: NA
- Color: Bin as defined on page 3
- CRI: NA

Packing Configuration:

- Maximum stack of 5 trays per pack with 10 devices per tray
- Partial pack or tray may be shipped
- Each pack is enclosed in anti-static bag
- Shipping label is placed on top of each pack



Notes

Static Electricity

This product is sensitive to static electricity, and care should be taken when handling them. Static electricity or surge voltage will damage the LEDs. It is recommended to wear an anti-electrostatic wristband or anti-electrostatic gloves when handling the LEDs. All devices, equipment and machinery must be properly grounded. It is recommended that measures be taken to isolate LED processing equipment from potential sources of voltage surges.

Reference: APN-002815 Electrical Stress Damage to LEDs and How to Prevent It

Eye Safety

According to the test specification risk group IEC 62471: 2006-Worst case under 15 A, this product complies to Risk group 0 (RG0) Exempt.

No photo biological hazard under foreseeable conditions.

For more information, please refer to: <https://luminusdevices.zendesk.com/hc/en-us/articles/10532958752397>.



Revision History

Rev	Date	Description of Change
01	11/25/2024	Initial release.