

MP-5050-810E

Mid Power LED



Features

- High efficacy
- CRI Options: Minimum 70,80 and 90
- Low thermal resistance
- Compatible with automatic placement equipment
- Compatible with infrared reflow solder process
- RoHs and REACH compliant



Applications

- Replacement lamps
- Panel lighting
- Down lights
- Architectural lighting

Table of Contents

Product Selection Table	2
Binning Structure	3
Operating Characteristics	4
Chromaticity Diagram	5
Characteristics Graphs	6
Package dimension	8
Solder Profile	9
Package Dimensions	10
Inner Box	12



PRODUCT ORDERING AND SHIPPING PART NUMBER NOMENCLATURE

All mid power products are packaged and labeled with part numbers as outlined in below. When shipped, each reel will contain only a single flux and voltage bin. The part number designation is as follows:

5050 Mid Power LED

	Package Type	Package Configurator	Nominal CCT	Minimum CRI
MP	5050	810E	##	##

Example :

The part number MP-5050-810E-40-90 refers to a 5050 emitter with nominal color temperature of 4,000K and minimum CRI of 90. Please refer to page for a description of available CCT and CRI combinations.

PRODUCT SELECTION TABLE

Test condition = 45 mA ($T_c=25^\circ\text{C}$)

Nominal CCT	Minimum CRI	Ordering Part Number	Minimum Flux (Lumens)	Typical Flux (Lumens)	Typical Efficiency (lm/W)
2700K	70	MP-5050-810E-27-70	182	209	209
	80	MP-5050-810E-27-80	182	198	198
	90	MP-5050-810E-27-90	156	168	168
3000K	70	MP-5050-810E-30-70	200	221	221
	80	MP-5050-810E-30-80	182	209	209
	90	MP-5050-810E-30-90	164	177	177
4000K	70	MP-5050-810E-40-70	220	233	233
	80	MP-5050-810E-40-80	200	221	221
	90	MP-5050-810E-40-90	172	187	187
5000K	70	MP-5050-810E-50-70	220	233	233
	80	MP-5050-810E-50-80	200	221	221
	90	MP-5050-810E-50-90	172	187	187
5700K	70	MP-5050-810E-57-70	220	233	233
	80	MP-5050-810E-57-80	200	221	221
	90	MP-5050-810E-57-90	172	187	187
6500K	70	MP-5050-810E-65-70	220	233	233
	80	MP-5050-810E-65-80	200	221	221
	90	MP-5050-810E-65-90	172	187	187



BINNING STRUCTURE

Each mid power product shipped will be labeled with its specific flux and voltage bins. Not all bins listed are available in all CCTs and CRIs.

Flux Bins

Bin Code	Minimum Flux (Lumens)	Maximum Flux (Lumens)
2H	148	156
2J	156	164
2K	164	172
2L	172	182
2M	182	200
2N	200	220
2P	220	240
2Q	240	260

Forward Voltage

Bin Code	Minimum Voltage (Volts)	Maximum Voltage (Volts)
1Q	20	21
1R	21	22
1S	22	23

*Tolerance of measurements of the Forward Voltage is $\pm 0.1V$



MP-5050 MID POWER OPERATING CHARACTERISTICS

Optical and Electrical Characteristics($T_c = 25^\circ\text{C}$)

Parameter	Symbol	Minimum	Typical	Maximum	Unit	Condition
Forward Voltage	V_f	21	22	23	V	$I_f=45\text{mA}$
Reverse Current	I_r			10	μA	$V_r=5\text{V}$
View Angle	$2\theta^{1/2}$		115		$^\circ$	$I_f=45\text{mA}$
Thermal Resistance	$R_{th_{f-sp}}$		2		$^\circ\text{C}/\text{W}$	$I_f=45\text{mA}$
Electrostatic Discharge	ESD	1000			V	

Note 1: To prevent damage refer to operating conditions and derating curves for appropriate maximum operating conditions

Note 2: Maximum operating case temperature combined with maximum drive current defines the total maximum operating condition for the device. To prevent damage, please follow derating curves for all operating conditions.

Note 3: Mid power LEDs are designed for operation up to an absolute maximum forward drive current as specified below. Product lifetime data is specified at typical forward drive currents. Sustained operation at absolute maximum currents will result in a reduction of device lifetime compared to typical forward drive currents. Actual device lifetimes will also depend on case temperature. Refer to the current vs. case temperature derating curves for further information.

Note 4: Caution must be taken not to stare at the light emitted from these LEDs. Under special circumstances, the high intensity could damage *the eye*.

Absolute Maximum Ratings

Parameter	Symbol	Rating	Unit
Forward Current	I_f	240	mA
Pulse Forward Current	I_{fp}	300	mA
Power Dissipation	P_d	5520	mW
Reverse Voltage	V_r	5	V
Operating Temperature	T_{opr}	-40~+105	$^\circ\text{C}$
Storage Temperature	T_{stg}	-40~+105	$^\circ\text{C}$
Junction Temperature	T_j	125	$^\circ\text{C}$



CHROMATICITY DIAGRAM AND COORDINATE GROUP

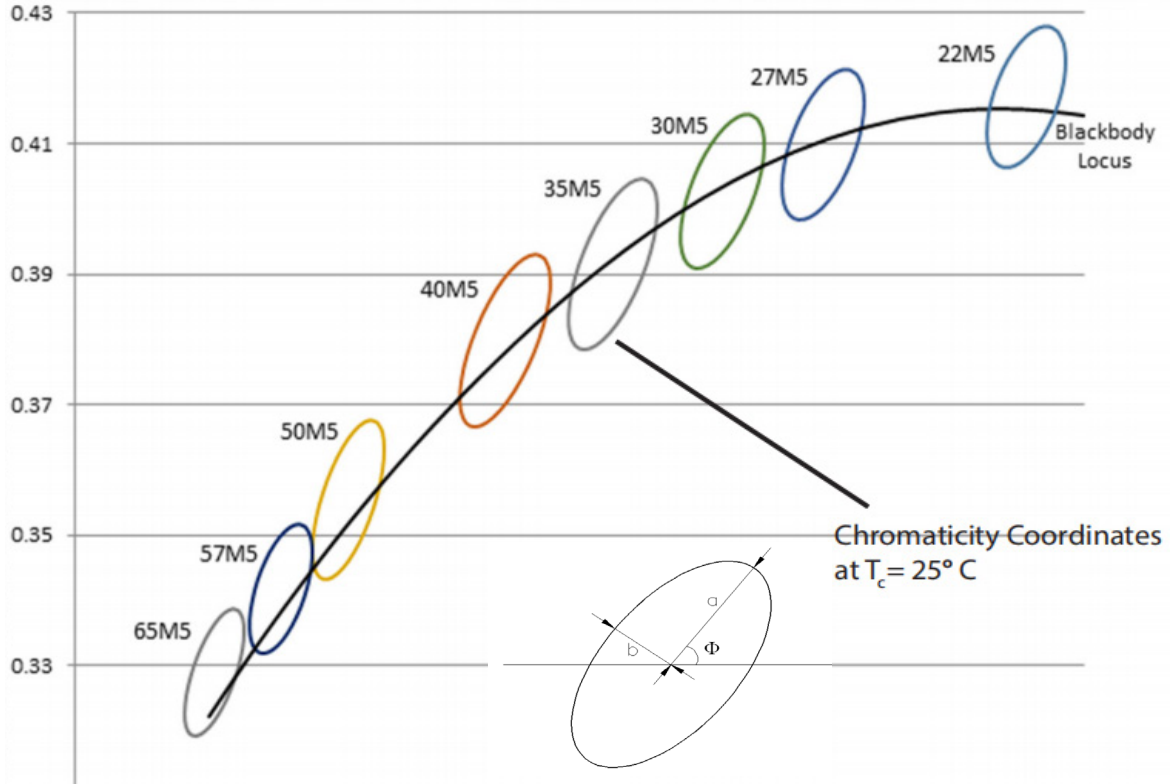

Color Bins

Color Code	Center		Radius		Angle(deg)
	x	y	a	b	Φ
22M5	0.5065	0.4171	0.012500	0.00700	53.00
27M5	0.4582	0.4099	0.013500	0.007000	53.42
30M5	0.4342	0.4028	0.013900	0.006800	53.13
35M5	0.4080	0.3916	0.015450	0.006900	54.00
40M5	0.3825	0.3798	0.015650	0.006700	53.43
50M5	0.3451	0.3554	0.013700	0.005900	59.37
57M5	0.3290	0.3417	0.011175	0.005500	58.35
65M5	0.3130	0.3290	0.011150	0.004750	58.34



TYPICAL OPTICAL/ELECTRICAL CHARACTERISTICS GRAPHS

Color Spectrum (CRI \geq 70 Tc=25°C)

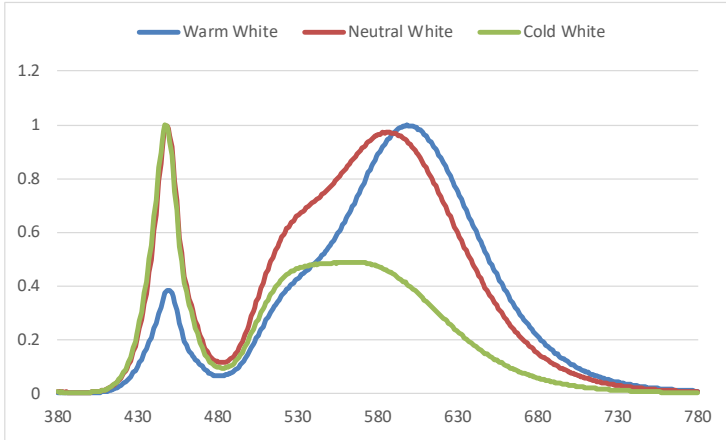

Color Spectrum (CRI \geq 80 Tc=25°C)

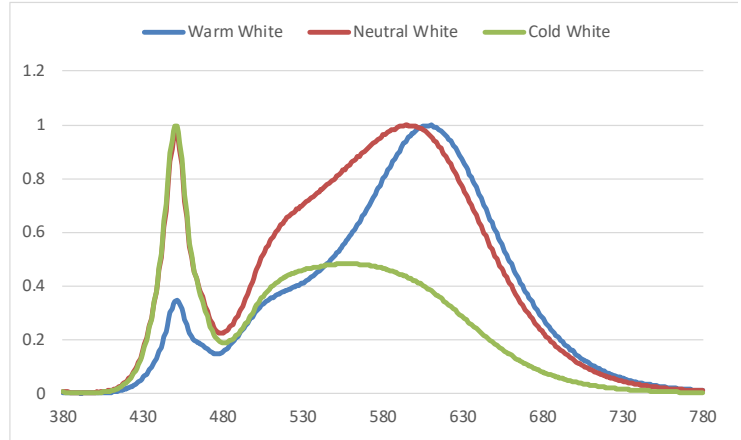

Color Spectrum (CRI \geq 90 Tc=25°C)

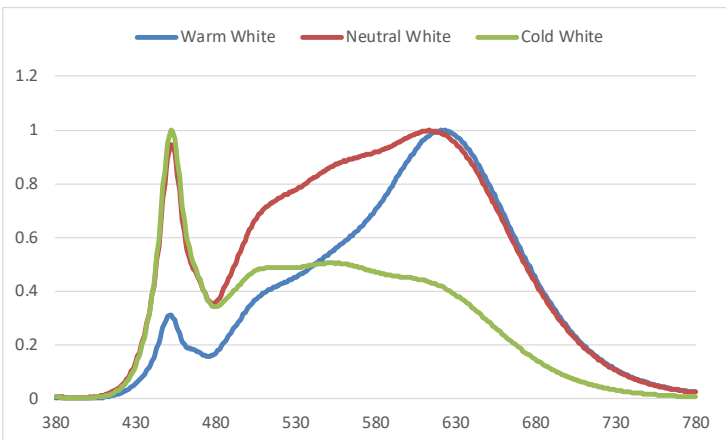

Forward Current vs. Forward Voltage (Tc = 25°C)

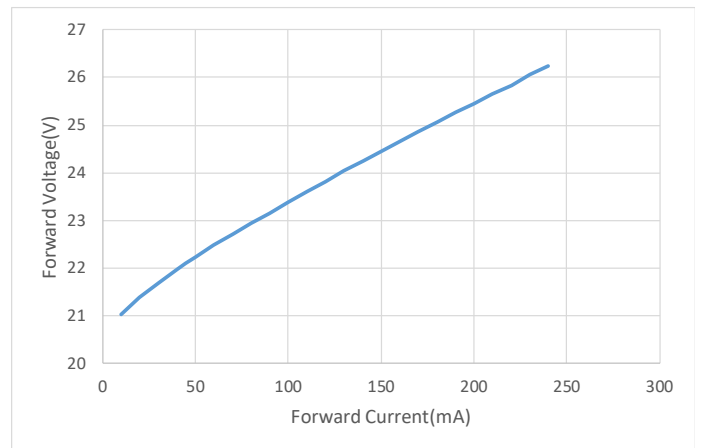

Forward Current vs. Relative Intensity (Tc = 25°C)

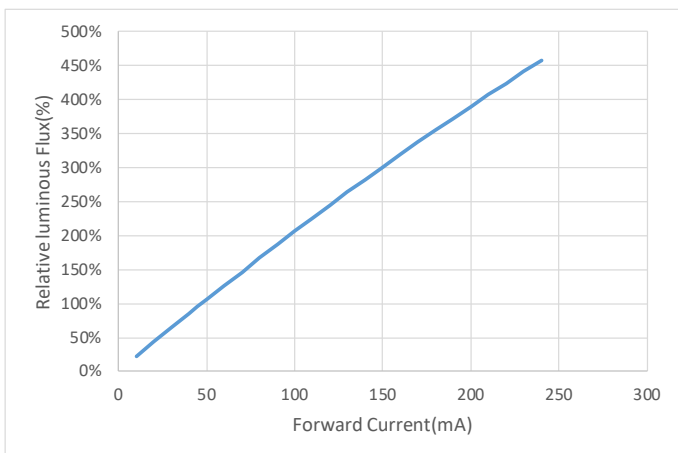

Case Temperature vs. Forward Voltage (IF=45mA)

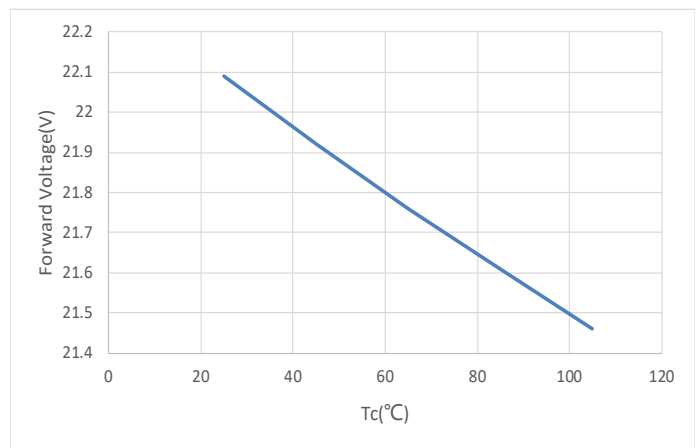



TYPICAL OPTICAL/ELECTRICAL CHARACTERISTICS GRAPHS

Case Temperature vs. Relative Luminous flux (IF=45mA)

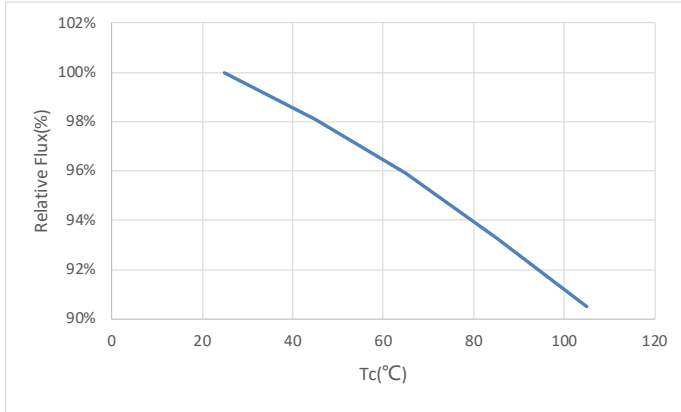

Case Temperature VS. CIE X, Y SHIFT

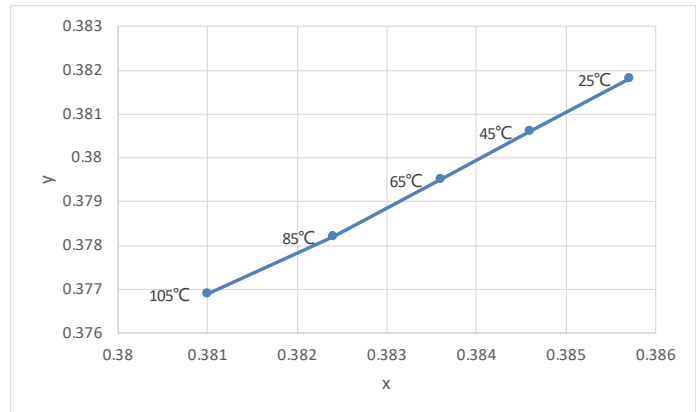

MAX FORWARD CURRENT VS. SOLDERING TEMP.

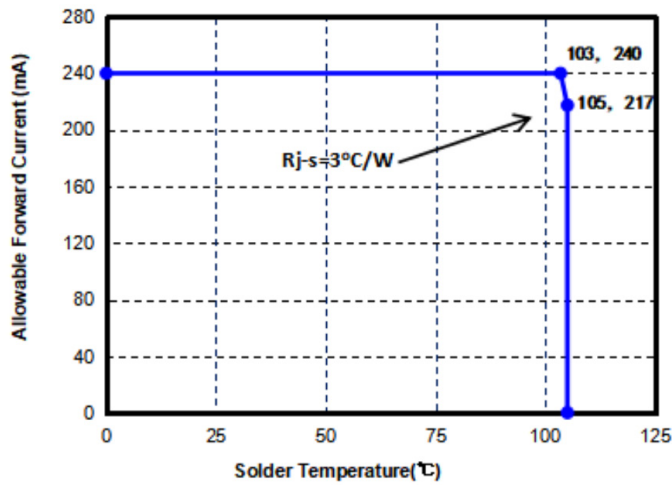

Viewing Angle Distribution (T_j = 25°C)

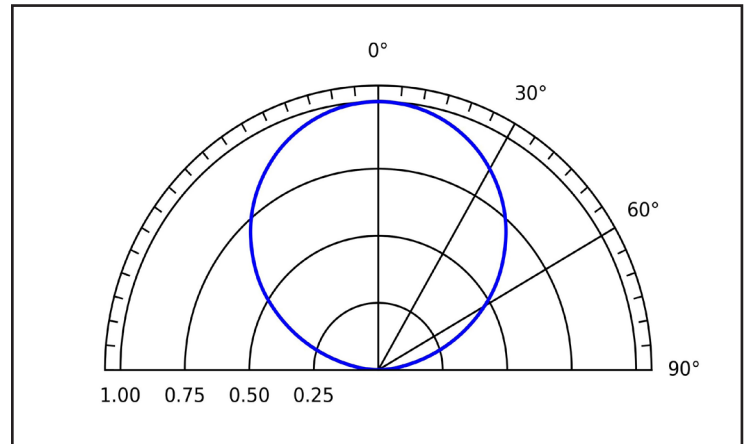



PACKAGE DIMENSION (MM) AND SOLDERING PAD PATTERN

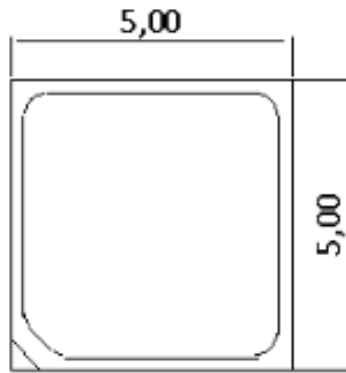

② Anode ① Cathode

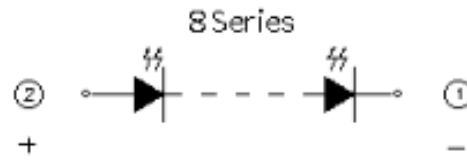

Polarity

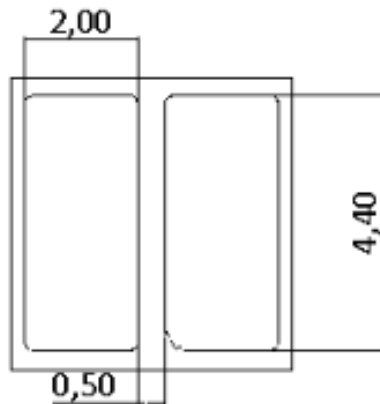
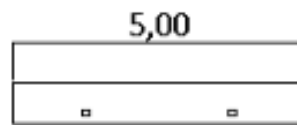
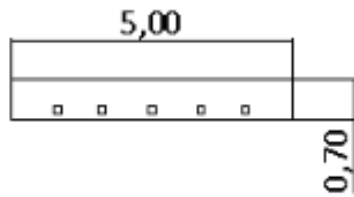

Bot. view

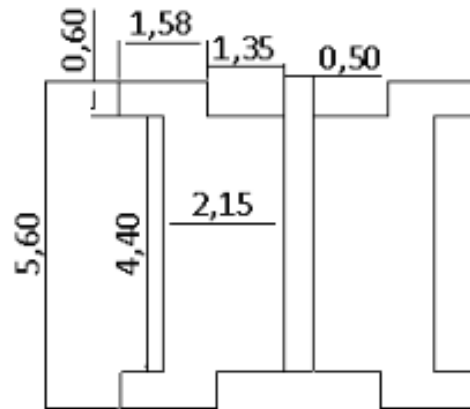

Soldering patterns

Note: tolerance : .X: $\pm 0.10\text{mm}$.XX: $\pm 0.05\text{mm}$



SOLDER PROFILE

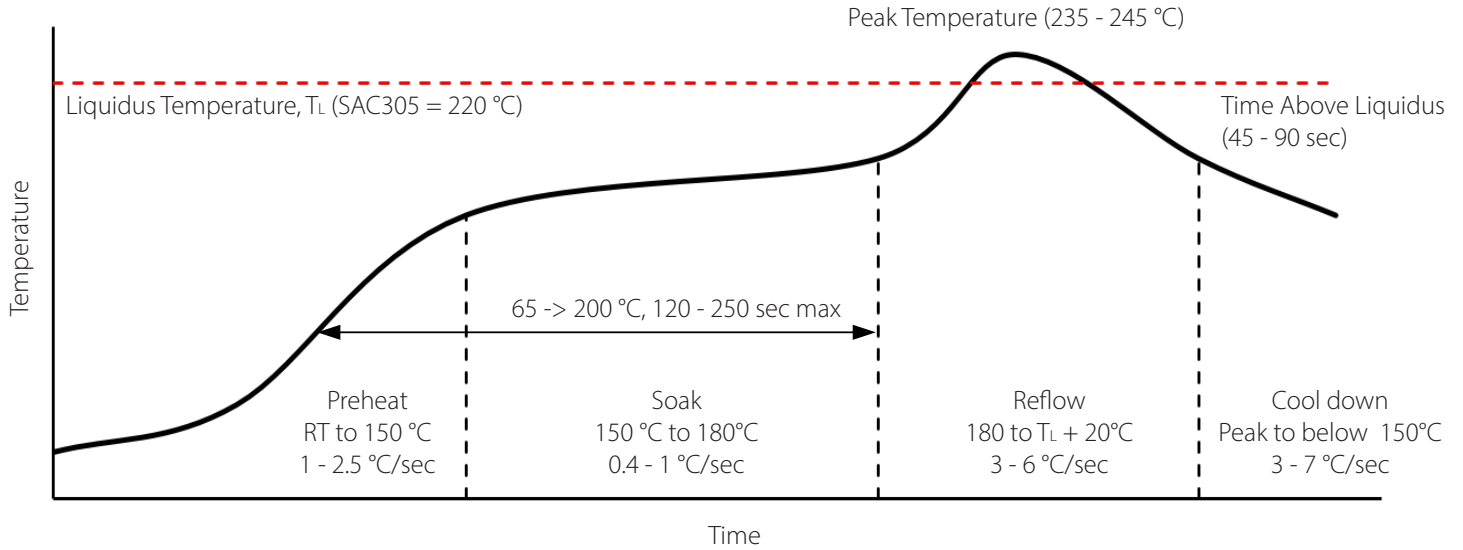

SMT Rework Guideline	Manual Hotplate Reflow	Hot Air Gun Reflow
Heating Time	< 60 sec	

Note 1: Product complies to Moisture Sensitivity Level 3 (MSL 3).

Note 2: The numbers in the table are specific to SAC305. Luminus recommends using an SAC305 solder paste with a no-clean flux for RoHS compliant products.

Note 3: During the pick and place process, axial forces on the dome (or window) should not exceed 0.5 Newtons (N).

Note 4: Use of a multi-zone IR reflow oven with a nitrogen blanket is recommended.

Note 5: Time-temperature profile of the reflow process showing the four functional profile zones are defined in IPC-7801. Temperature is referenced to the center of the PCB.

Note 6: Luminus recommends to use the solder paste data sheet information as a starting point in time-temperature process development.

Note 7: These are general guidelines. Consult the solder paste manufacturer's datasheet for guidelines specific to the alloy and flux combination used in your application. For more information, please refer to:

<https://luminusdevices.zendesk.com/hc/en-us/articles/360060306692-How-do-I-Reflow-Solder-Luminus-SMD-Components->

Note 8: For any technical questions about soldering process, please contact Luminus at techsupport@luminus.com.



PACKAGE DIMENSIONS OF TYPE(MM)

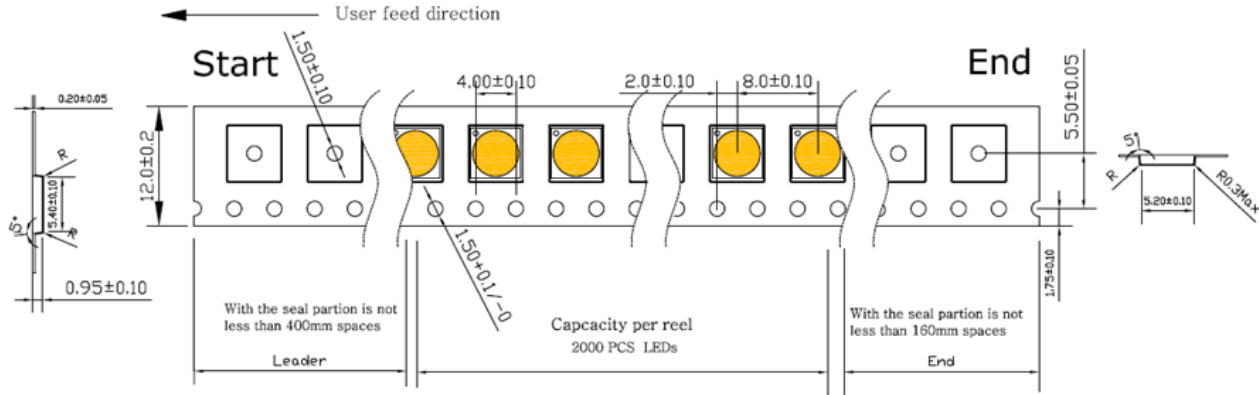

*Quantity : Max 2000pcs/Reel

*Cumulative Tolerance : Cumulative Tolerance/10 pitches to be ± 0.2 mm

*Adhesion Strength of Cover Tape Adhesion strength to be 0.1-0.7N when the cover tape is turned off from the carrier tape at the angle of 10° to the carrier tape.

*Package : P/N, Manufacturing data Code No. and Quantity to be indicated on a damp proof Package



PACKAGE DIMENSIONS OF REEL (MM)

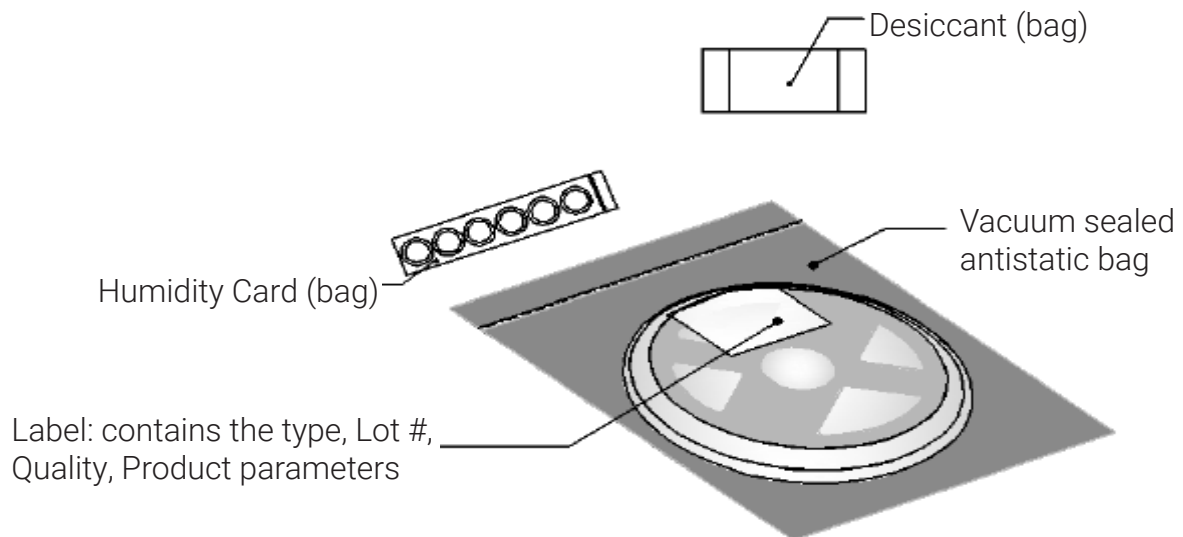
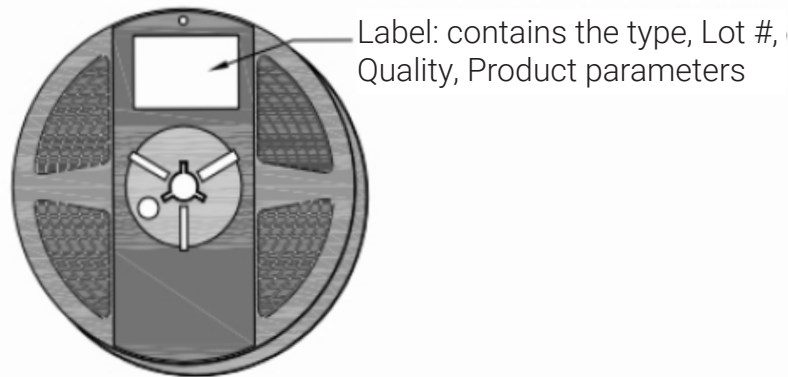
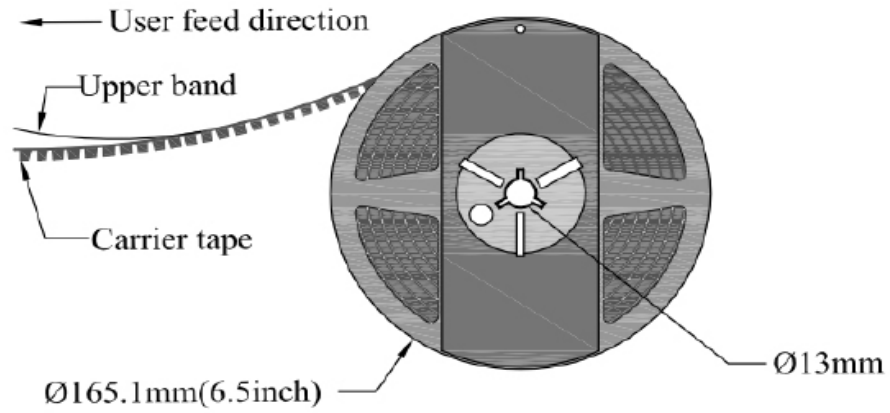



BOX PACKAGING

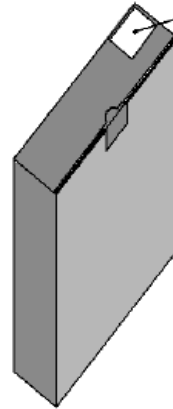
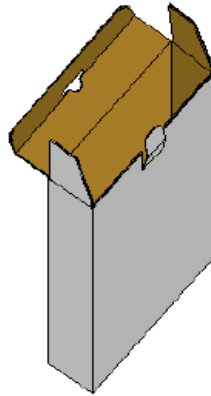

Label: contains the type, Lot #, Quality, Product parameters

*Capacity 5 reels per box

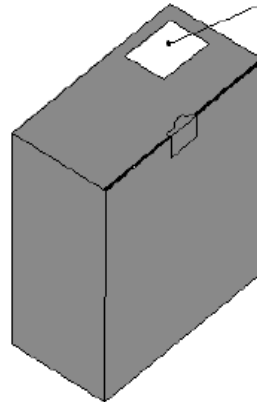
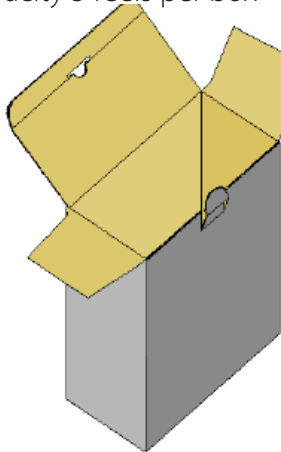

Label: contains the type, Lot #, Quality, Product parameters

*Capacity 10 reels per box

LABEL



RoHS Compliant

Rev.01



Flux: ** Color: ***

Voltage: ** CRI: **





QTY: ***





PRECAUTION FOR USE

STORAGE

1. This device is rated at MSL 3 per JEDEC J-STD-020 standard.
2. Recommended storage condition:
At 5 °C- 30 °C and relative humidity 60% RH in its original package
3. After this bag is opened, devices that will be applied to infrared reflow, vapor - phase reflow, or equivalent soldering process must be:
 - a) Completed within 168 hours
 - b) Stored at less than 60%RH
 - c) If not completely used within 168 hours, seal the remaining in the moisture barrier bag
4. Devices require baking before mounting, if 3 a) is not met.
5. If baking is required, devices must be baked under below conditions:
24 hours at 60C+/-5C

STATIC ELECTRICITY

1. The products are sensitive to static electricity, and care should be taken when handling them.
2. Static electricity or surge voltage will damage the LEDs. It is recommended to wear a anti-electrostatic wristband or an anti-electrostatic gloves when handling the LEDs.
3. All devices, equipment and machinery must be properly grounded. It is recommended that measures be taken against surge voltage to the equipment that mounts the LEDs.