

MP-5050-810H

Mid Power LED

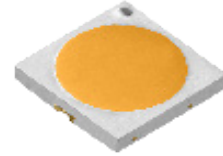

Features

- High efficacy
- CRI Options: Minimum 90
- Low thermal resistance
- Compatible with automatic placement equipment
- Compatible with infrared reflow solder process
- RoHs and REACH compliant



Applications

- Replacement lamps
- Panel lighting
- Down lights
- Architectural lighting

Table of Contents

Product Selection Table	2
Binning Structure	3
Operating Characteristics	4
Chromaticity Diagram	5
Characteristics Graphs	6
Package dimension	8
Solder Profile.	9
Package Dimensions	10
Inner Box	12



PRODUCT ORDERING AND SHIPPING PART NUMBER NOMENCLATURE

All mid power products are packaged and labeled with part numbers as outlined in below. When shipped, each reel will contain only a single flux and voltage bin. The part number designation is as follows:

5050 Mid Power LED

	Package Type	Package Configurator	Nominal CCT	Minimum CRI
MP	5050	810H	##	##

Example :

The part number MP-5050-810H-40-90 refers to a 5050 emitter with nominal color temperature of 4,000K and minimum CRI of 90. Please refer to page for a description of available CCT and CRI combinations.

PRODUCT SELECTION TABLE

Test condition = 200 mA (T_c=25 °C)

Nominal CCT	Minimum CRI	Ordering Part Number	Minimum Flux (Lumens)	Typical Flux (Lumens)
2700K	70	MP-5050-810H-27-70	700	785
	80	MP-5050-810H-27-80	650	745
	90	MP-5050-810H-27-90	560	635
3000K	70	MP-5050-810H-30-70	700	825
	80	MP-5050-810H-30-80	700	785
	90	MP-5050-810H-30-90	600	665
4000K	70	MP-5050-810H-40-70	800	865
	80	MP-5050-810H-40-80	750	820
	90	MP-5050-810H-40-90	650	700
5000K	70	MP-5050-810H-50-70	800	865
	80	MP-5050-810H-50-80	750	820
	90	MP-5050-810H-50-90	650	700
5700K	70	MP-5050-810H-57-70	800	865
	80	MP-5050-810H-57-80	750	820
	90	MP-5050-810H-57-90	650	700
6500K	70	MP-5050-810H-65-70	800	860
	80	MP-5050-810H-65-80	750	815
	90	MP-5050-810H-65-90	650	690



BINNING STRUCTURE

All MP-5050-810H monochromatic LEDs are tested for luminous flux/ dominant wavelength and placed into one of the following flux/wave length bins. The binning structure is universally applied across each monochromatic color of the MP-5050-810H product line.

Flux Bins

Bin Code	Minimum Flux (Lumens)	Maximum Flux (Lumens)
3D	560	600
3E	600	650
3F	650	700
3G	700	800
3H	800	900

Forward Voltage

Bin Code	Minimum Voltage (Volts)	Maximum Voltage (Volts)
C	23	24
D	24	25
E	25	26
F	26	27

*Tolerance of measurements f the Forward Voltage is $\pm 0.1V$



MP-5050 MID POWER OPERATING CHARACTERISTICS

Optical and Electrical Characteristics($T_c = 25^\circ\text{C}$)

Parameter	Symbol	Rating	Unit	Maximum	Unit	Condition
Forward Voltage	V_f	23	24.5	27	V	$I_f=200\text{mA}$
Reverse Current	I_r			10	μA	$V_r=5\text{V}$
View Angle	$2\theta^{1/2}$		115		°	$I_f=200\text{mA}$
Thermal Resistance	$R_{th_{j-sd}}$		2		$^\circ\text{C}/\text{W}$	$I_f=200\text{mA}$
Electrostatic Discharge	ESD	1000			V	

Note 1: To prevent damage refer to operating conditions and derating curves for appropriate maximum operating conditions

Note 2: Maximum operating case temperature combined with maximum drive current defines the total maximum operating condition for the device. To prevent damage, please follow derating curves for all operating conditions.

Note 3: Mid power LEDs are designed for operation up to an absolute maximum forward drive current as specified below. Product lifetime data is specified at typical forward drive currents. Sustained operation at absolute maximum currents will result in a reduction of device lifetime compared to typical forward drive currents. Actual device lifetimes will also depend on case temperature. Refer to the current vs. case temperature derating curves for further information.

Note 4: Caution must be taken not to stare at the light emitted from these LEDs. Under special circumstances, the high intensity could damage *the eye*.

Absolute Maximum Ratings

Parameter	Symbol	Rating	Unit
Forward Current	I_f	240	mA
Pulse Forward Current	I_{fp}	300	mA
Power Dissipation	P_d	6480	mW
Reverse Voltage	V_r	5	V
Operating Temperature	T_{opr}	-40~+105	$^\circ\text{C}$
Storage Temperature	T_{stg}	-40~+105	$^\circ\text{C}$
Junction Temperature	T_j	125	$^\circ\text{C}$



CHROMATICITY DIAGRAM AND COORDINATE GROUP

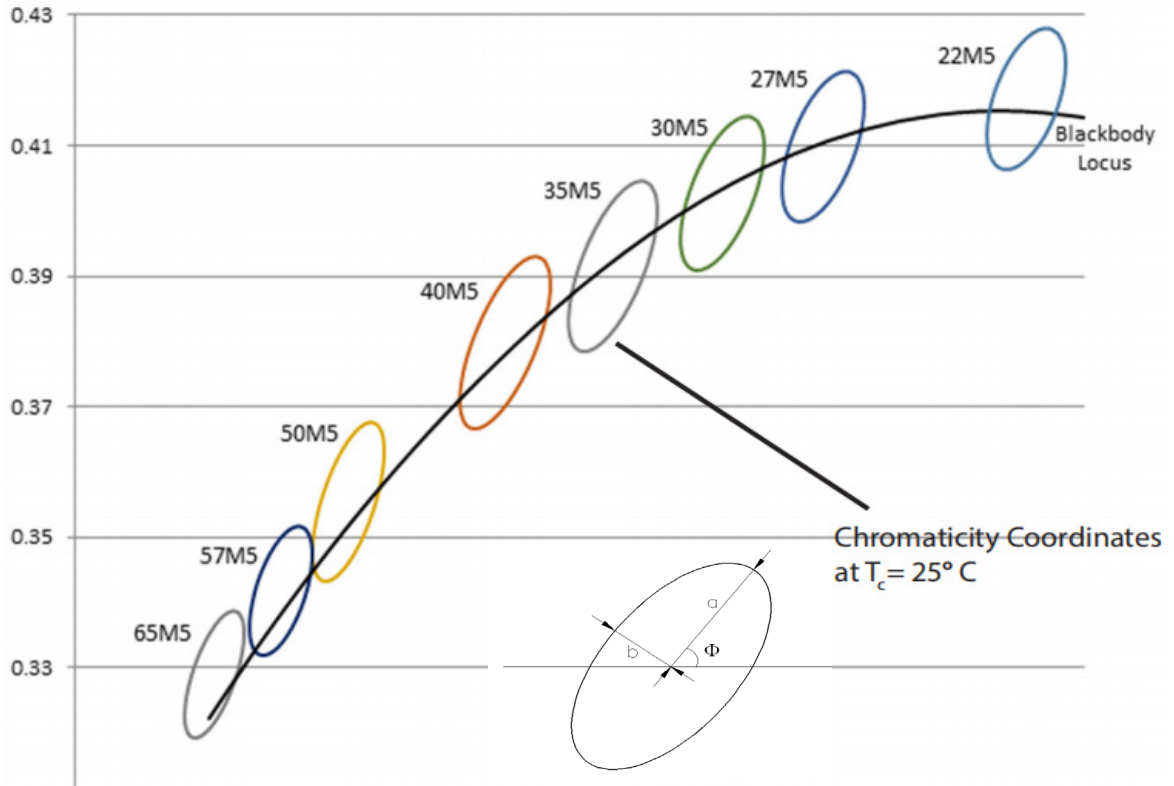

Color Bins

Color Code	Center		Radius		Angle(deg)
	x	y	a	b	
22M5	0.5065	0.4171	0.012500	0.00700	53.00
27M5	0.4582	0.4099	0.013500	0.007000	53.42
30M5	0.4342	0.4028	0.013900	0.006800	53.13
35M5	0.4080	0.3916	0.015450	0.006900	54.00
40M5	0.3825	0.3798	0.015650	0.006700	53.43
50M5	0.3451	0.3554	0.013700	0.005900	59.37
57M5	0.3290	0.3417	0.011175	0.005500	58.35
65M5	0.3130	0.3290	0.011150	0.004750	58.34



TYPICAL OPTICAL/ELECTRICAL CHARACTERISTICS GRAPHS

Color Spectrum (Ra≥90 Tj=25oC)

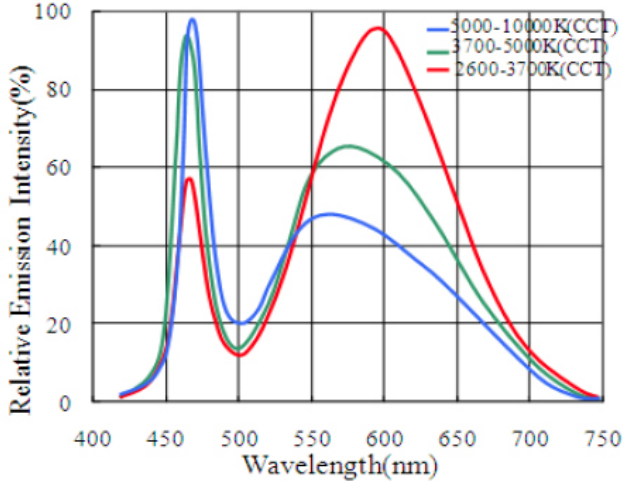

Forward Current vs. Forward Voltage(Tj = 25°C)

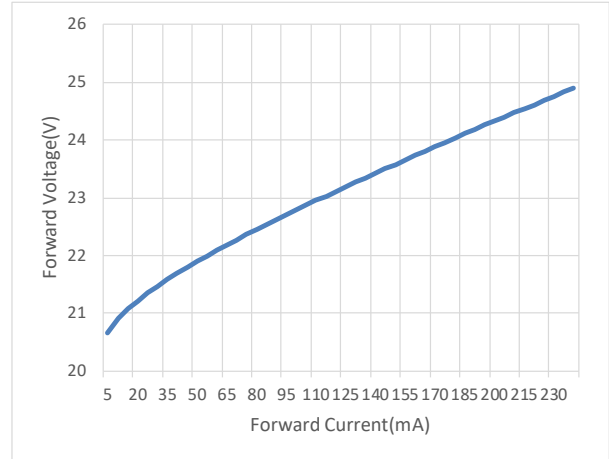

Forward Current vs. Relative Intensity(Tj = 25°C)

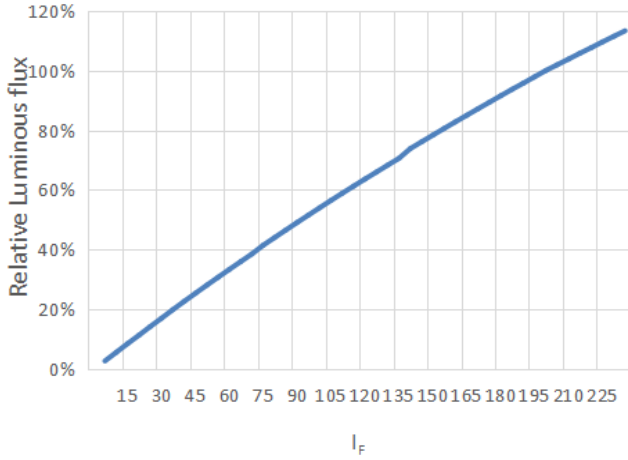

Solder Point Temperature vs. Relative Forward Voltage (IF=150mA)

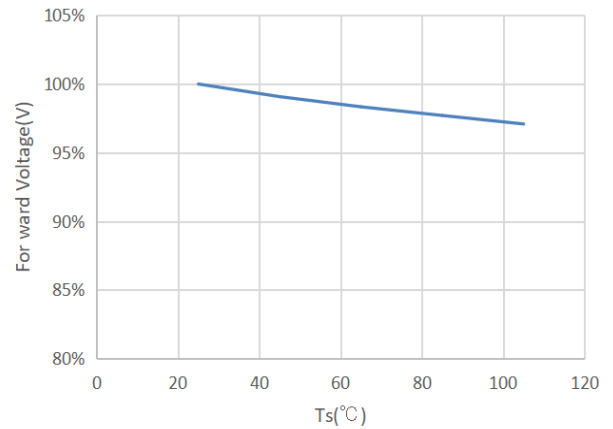

Solder Point Temperature vs. Relative Luminous

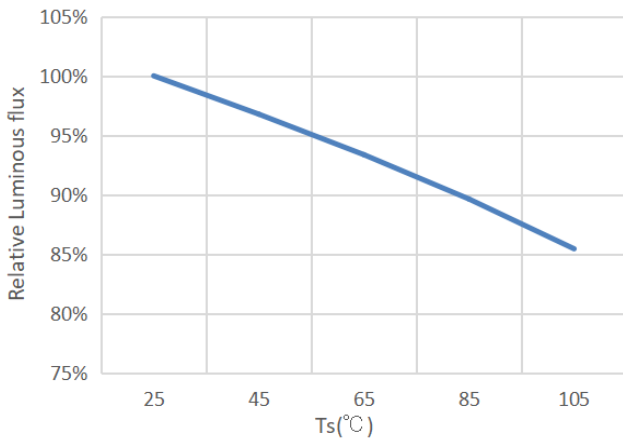

SOLDERING TEMP. VS. CIE X, Y SHIFT

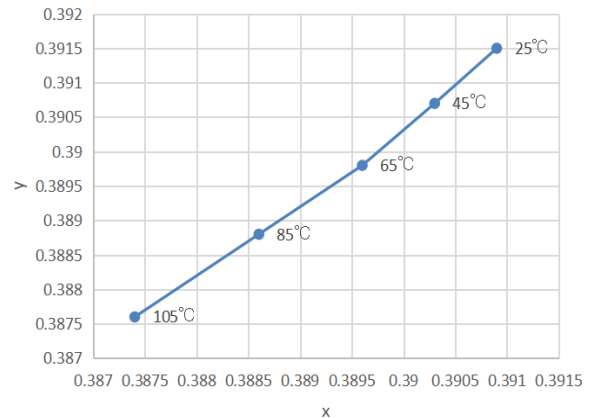



TYPICAL OPTICAL/ELECTRICAL CHARACTERISTICS GRAPHS

MAX FORWARD CURRENT VS. SOLDERING TEMP.

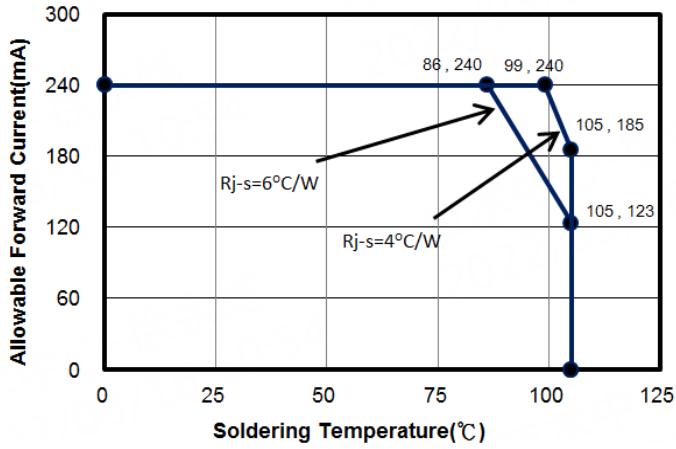

Viewing Angle Distribution ($T_j = 25^{\circ}\text{C}$)

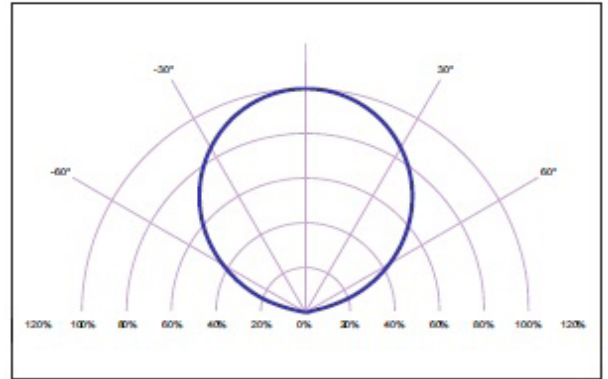



PACKAGE DIMENSION (MM)

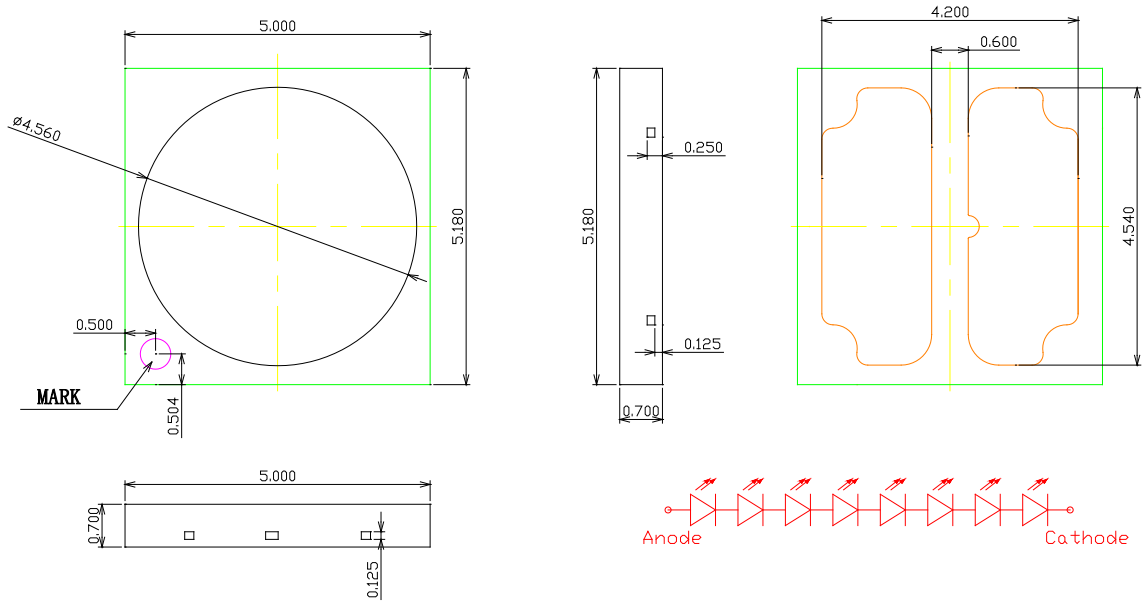

Recommended Soldering Pad Pattern

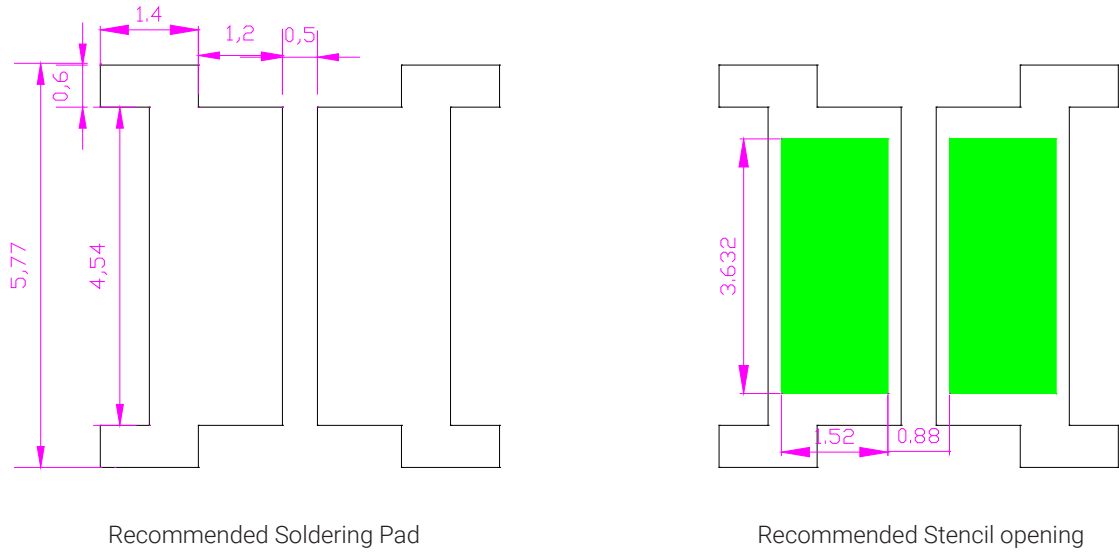

Note: tolerance : .X: ± 0.10 mm .XX:



SOLDER PROFILE

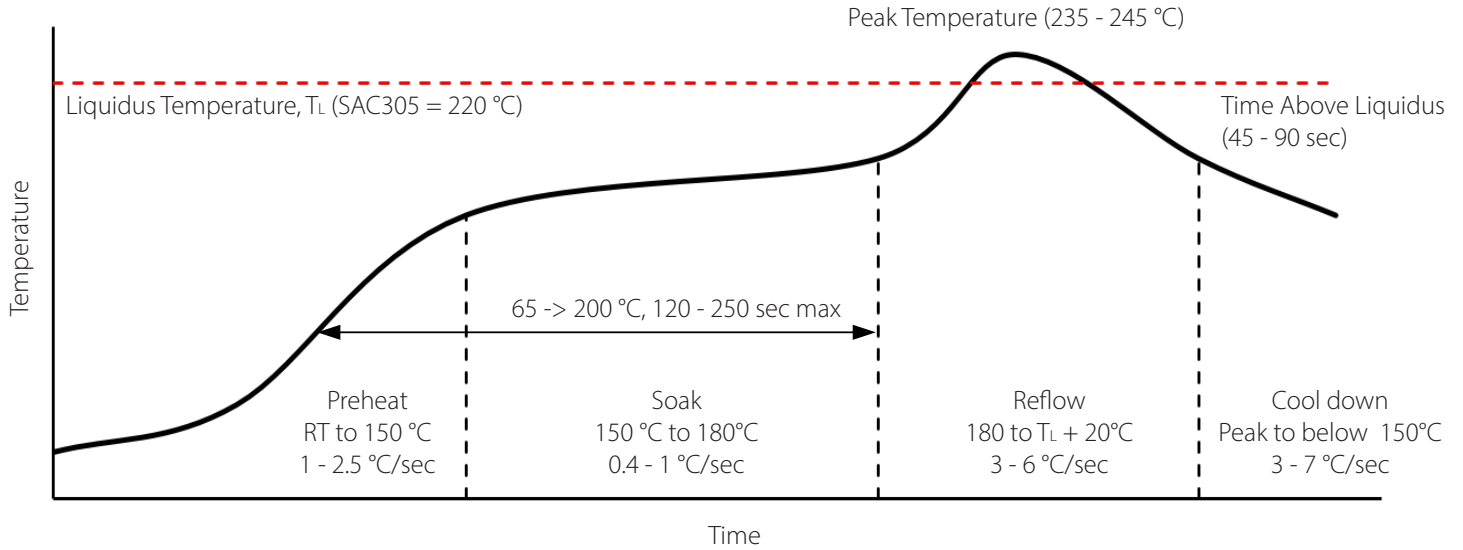

SMT Rework Guideline	Manual Hotplate Reflow	Hot Air Gun Reflow
Heating Time	< 60 sec	

Note 1: Product complies to Moisture Sensitivity Level 3 (MSL 3).

Note 2: The numbers in the table are specific to SAC305. Luminus recommends using an SAC305 solder paste with a no-clean flux for RoHS compliant products.

Note 3: During the pick and place process, axial forces on the dome (or window) should not exceed 0.5 Newtons (N).

Note 4: Use of a multi-zone IR reflow oven with a nitrogen blanket is recommended.

Note 5: Time-temperature profile of the reflow process showing the four functional profile zones are defined in IPC-7801. Temperature is referenced to the center of the PCB.

Note 6: Luminus recommends to use the solder paste data sheet information as a starting point in time-temperature process development.

Note 7: These are general guidelines. Consult the solder paste manufacturer's datasheet for guidelines specific to the alloy and flux combination used in your application. For more information, please refer to:

<https://luminusdevices.zendesk.com/hc/en-us/articles/360060306692-How-do-I-Reflow-Solder-Luminus-SMD-Components->

Note 8: For any technical questions about soldering process, please contact Luminus at techsupport@luminus.com.

PACKAGE DIMENSIONS OF TYPE(MM)

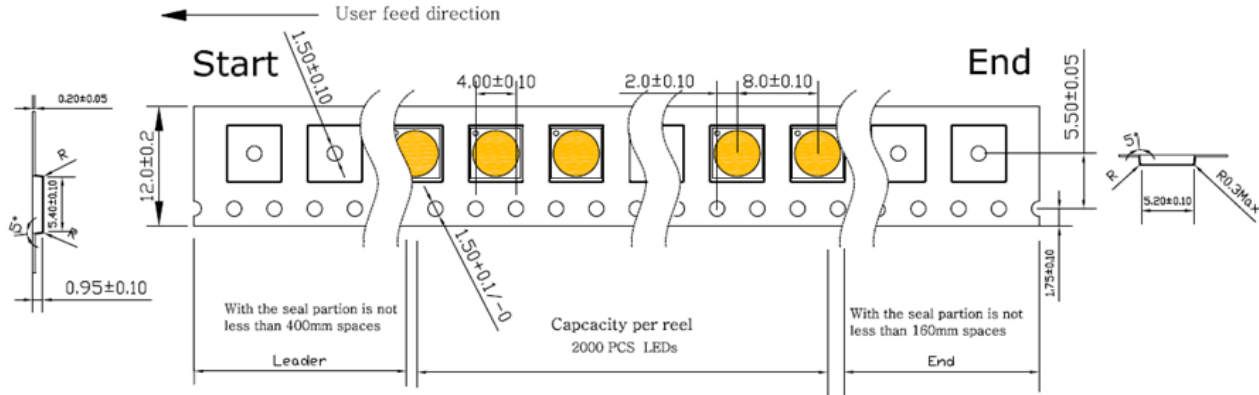

*Quantity : Max 2000pcs/Reel

*Cumulative Tolerance : Cumulative Tolerance/10 pitches to be ± 0.2 mm

*Adhesion Strength of Cover Tape Adhesion strength to be 0.1-0.7N when the cover tape is turned off from the carrier tape at the angle of 10° to the carrier tape.

*Package : P/N, Manufacturing data Code No. and Quantity to be indicated on a damp proof Package



PACKAGE DIMENSIONS OF REEL (MM)

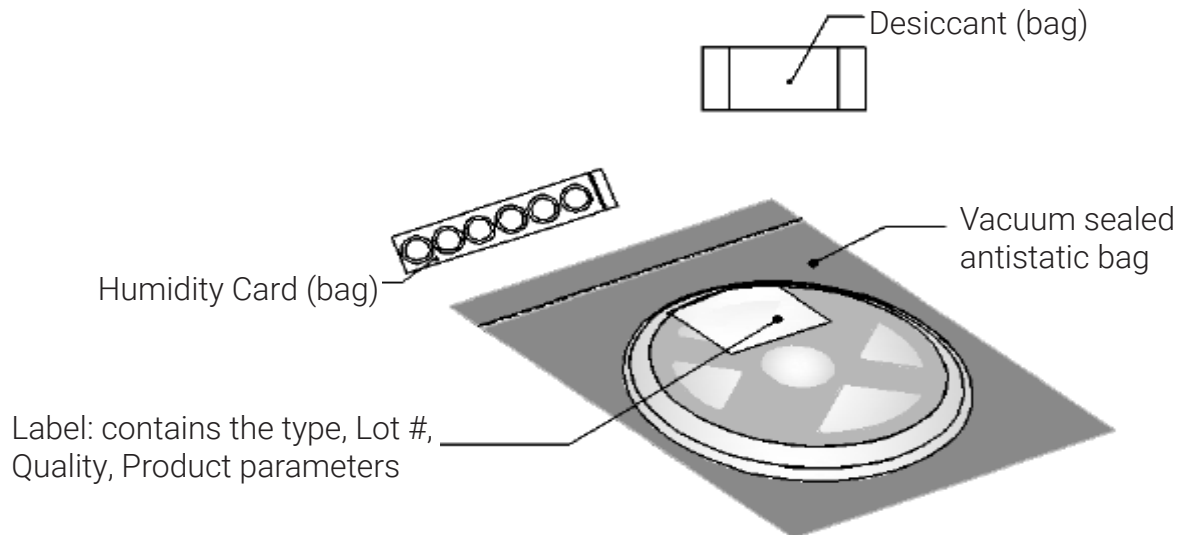
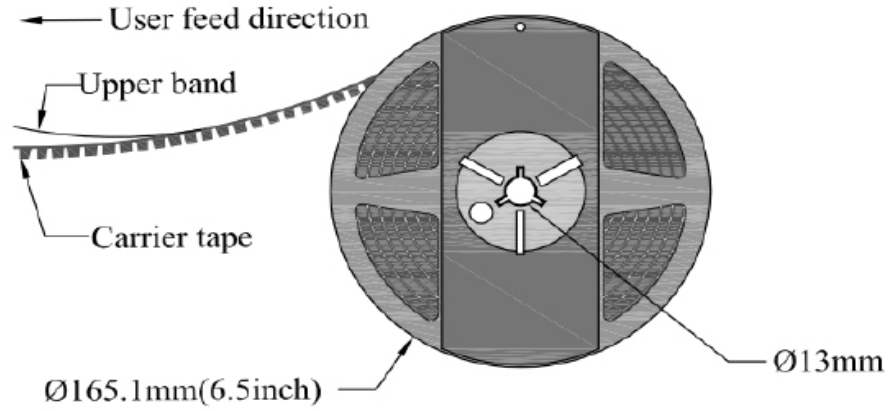



BOX PACKAGING

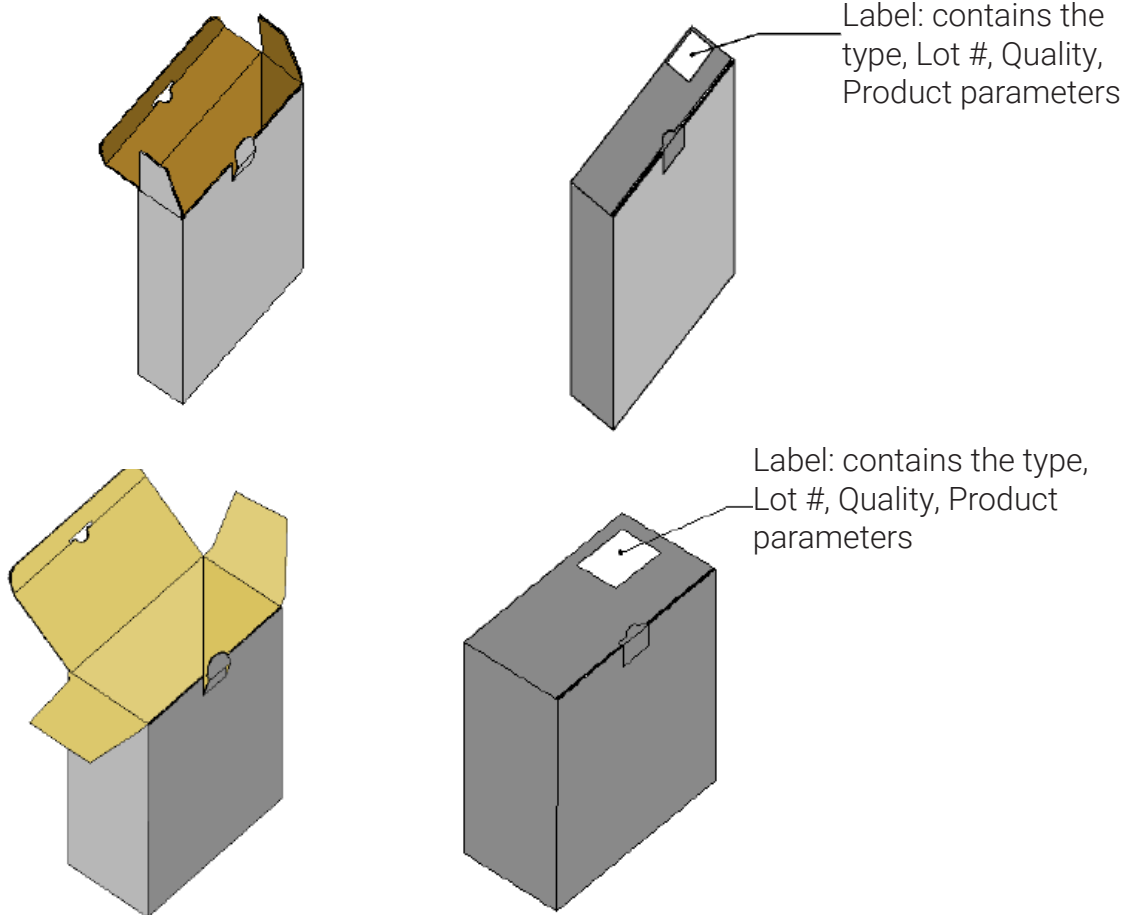

*Capacity 10 reels per box

LABEL

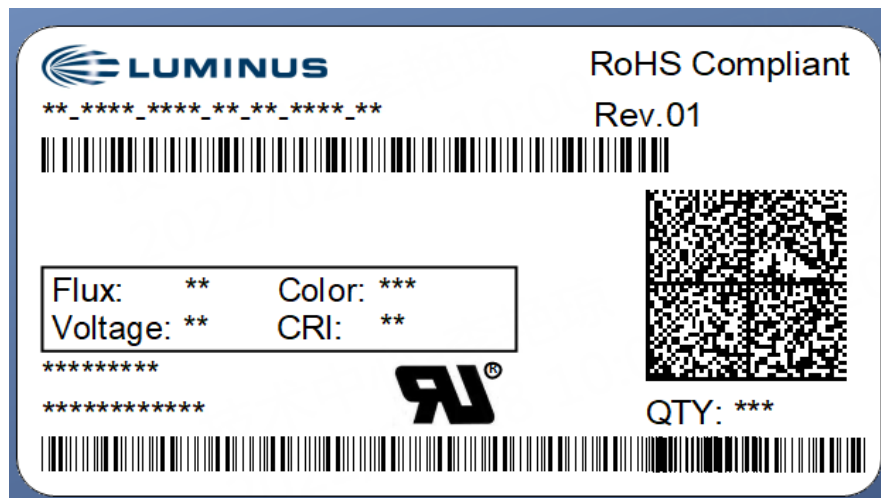



PRECAUTION FOR USE

STORAGE

1. This device is rated at MSL 3 per JEDEC J-STD-020 standard.
2. Recommended storage condition:
At 5 °C- 30 °C and relative humidity 60% RH in its original package
3. After this bag is opened, devices that will be applied to infrared reflow, vapor - phase reflow, or equivalent soldering process must be:
 - a) Completed within 168 hours
 - b) Stored at less than 60%RH
 - c) If not completely used within 168 hours, seal the remaining in the moisture barrier bag
4. Devices require baking before mounting, if 3 a) is not met.
5. If baking is required, devices must be baked under below conditions:
24 hours at 60C+/-5C

STATIC ELECTRICITY

1. The products are sensitive to static electricity, and care should be taken when handling them.
2. Static electricity or surge voltage will damage the LEDs. It is recommended to wear a anti-electrostatic wristband or an anti-electrostatic gloves when handling the LEDs.
3. All devices, equipment and machinery must be properly grounded. It is recommended that measures be taken against surge voltage to the equipment that mounts the LEDs.