

SFT-10-B

SFT-10-BP

Projection LED



Features

- 1.0 mm² LED emitting area
- Complement to SFT-10 Red Amber (RA) and Converted Green (CG) for best projection brightness and color gamut
- Drive current up to 5 A
- Standard 3535 SMT package
- Low thermal resistance $R_{th_Junction\ to\ Case} = 3.0^{\circ}C/W$
- Dominant wavelength: Blue 457nm, Blue pump 448nm
- Flat surface emission for high collection efficiency



Applications

- Suitable for micro-display sizes 0.3x" and 0.2x"
- Medical / Life Science
- Industrial
- Obstruction Lighting and Beacons
- Architectural Lighting
- Specifically engineered for stand alone, embedded, or battery-assisted projection display applications

Table of Contents

Ordering Information.	2
Binning Structure.	3
Absolute Maximum Ratings	4
Device Characteristics	5
Angular Distribution and Typical Spectrum.	7
Soldering Profile.	8
Mechanical Dimensions.	9
Tape and Reel Outline	11
Shipping Label	13
Notes	14
Revision History.	15



Ordering Information

Ordering Part Numbers¹

Color	Luminous Flux		Wavelength bin	Ordering Part Number
	Min. Flux Bin	Min. Power		
B	EPC	0.75 W	B2	SFT-10-B-F35-EPC
	EPD	0.85 W	B2	SFT-10-B-F35-EPD
BP	EPC	0.75 W	B0, B1	SFT-10-BP-F35-EPC
	EPD	0.85 W	B0, B1	SFT-10-BP-F35-EPD

Part Number Nomenclature

SFT	10	##	###	<Bin kit>
Product Family	Chip Area	Color	Package Configuration	Bin Kit
SFT: Surface-Mount Flat-Top	10: 1 mm ²	B: Blue BP: Blue Pump	F35: 3535 EMC SMD R35: 3535 EMC mounted on Star-Board ²	Refer to ordering part numbers in this document

Note:

1. Flux Bin listed is minimum bin shipped, higher bins may be included at Luminus' discretion.
2. Starboard Configuration R35 are available for small sample quantity only. For additional quantity, contact Luminus representative.



Binning Structure

All SFT-10 LEDs are tested for luminous flux/ dominant wavelength and placed into one of the following flux/wavelength bins. The binning structure is universally applied across each monochromatic color of the SFT-10 product line.

Flux Bins^{1,2}

Color	Luminous Flux Bin ³	Binning @ 0.7 A, T _c = 25°C ⁴	
		Minimum Power (W)	Maximum Power (W)
Blue	4C	0.75	0.85
	4D	0.85	0.95
	4E	0.95	1.05
	4F	1.05	1.15
	4G	1.15	1.25
	4H	1.25	1.35

Dominant Wavelength Bins²

Color	Wavelength Bin ^{3,5}	Binning @ 0.7 A, T _c = 25°C ⁴	
		Minimum Wavelength (nm)	Maximum Wavelength (nm)
Blue	B0	444	449
	B1	449	455
	B2	455	460

Note:

1. Luminus maintains a +/- 6% tolerance on flux measurements.
2. Products are production tested then sorted and packed by bin.
3. Individual bins are not orderable. Please refer to the Product Ordering information page for a list of orderable bin kits.
4. T_c = Case temperature.
5. The wavelength bin as marked on the product label may be followed by a letter which is for internal use only.



Absolute Maximum Ratings¹

	Symbol	Values	Unit
Forward Current (Single pulse 20 ms or Pulsed) ^{2,3,4}	$I_{f \text{ min}}$	0.2	A
	$I_{f \text{ max}}$	4.0	
Forward Current Pulsed ^{2,3,4} Frequency >240Hz, Duty <70%	$I_{fp \text{ min}}$	0.2	A
	$I_{fp \text{ max}}$	5.0	
Forward Surge Current (Pulsed) ^{2,3,4} Frequency >240Hz, duty cycle <10%, t=1ms	$I_{\text{surge max}}$	5.5	A
Storage Temperature	$T_{s \text{ min}}$	-40	°C
	$T_{s \text{ max}}$	100	
Junction Temperature	$T_{j \text{ max}}$	150	°C
ESD sensitivity ANSI/ESDA/JEDEC JS-001 (HBM, Class 2)	V_{ESD}	2000	V

Note:

1. All ratings are based on standard testing conditions at drive current 0.7 A, 20 ms single pulse at $T_c = 25^\circ\text{C}$.
2. In pulsed operation, rise time from 10% to 90% of forward current should be larger than 0.5 microseconds.
3. Product performance and lifetime data is specified at recommended forward drive current. Sustained operation at or near absolute minimum current may result in a reduction of device performance and device lifetime compared to recommended forward drive current.
4. Sustained operation above maximum current is not recommended and will result in a reduction of device lifetime.



Device Characteristics¹

Optical and Electrical Characteristics	Symbol	Blue	Blue Pump	Unit
Emitting Area	A_E	1.0	1.0	mm ²
Emitting Area Dimension		1.0 x 1.0	1.0 x 1.0	mm x mm
Reference Duty Cycle		100	100	%
Test Peak Drive Current	I_f	0.7	0.7	A
Peak Luminous Flux ²	Φ_V	38	40	lm
Peak Radiometric Flux ²	Φ_E	0.95	1.15	W
Forward Voltage	$V_{f \text{ min}}$	2.5	2.5	V
	V_f	3.0	3.0	
	$V_{f \text{ max}}$	3.6	3.6	
Dominant Wavelength	$\lambda_{d \text{ min}}$	449	444	nm
	$\lambda_{d \text{ typ}}$	455	448	
	$\lambda_{d \text{ max}}$	460	455	
Peak Wavelength	λ_p	452	443	nm
FWHM- Spectral bandwidth at 50% of Φ_V	$\Delta\lambda_{1/2}$	19	19	nm
Chromaticity Coordinates ³	CIE x	0.14	0.14	
	CIE y	0.04	0.04	
Thermal Characteristics				
Thermal Resistance (junction to case) ^{4,5}	$R_{th(j-c)}$	3.0		°C/W

Note:

- Product test condition: 0.7 A, 25°C case temperature.
- Typical flux at typical dominant wavelength.
- CIE 1931 chromaticity diagram coordinates, normalized to X+Y+Z=1.
- Thermal resistance values are based on modeled results correlated to measured $R_{th(j-c)}$ data using Forward Voltage sensitivity parametric method, compliant with JEDEC Standards JESD51-14.
- For optimal results, Luminus recommends customer PCB Design per guidelines from Luminus application note, "Design Guidelines for SFT Chipset Assembly".



Relative Radiometric Flux

Forward current: $\phi_f/\phi_f(0.7\text{ A}), T_c = 25^\circ\text{C}$

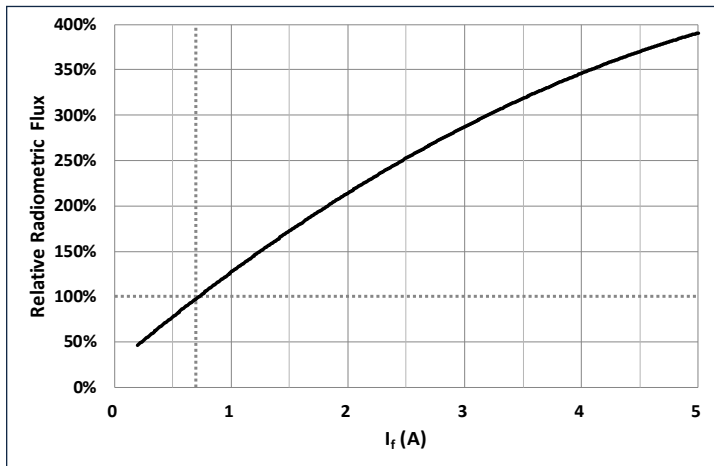

Temperature: $\phi_f/\phi_f(25^\circ\text{C}), I_f = 0.7\text{ A}$

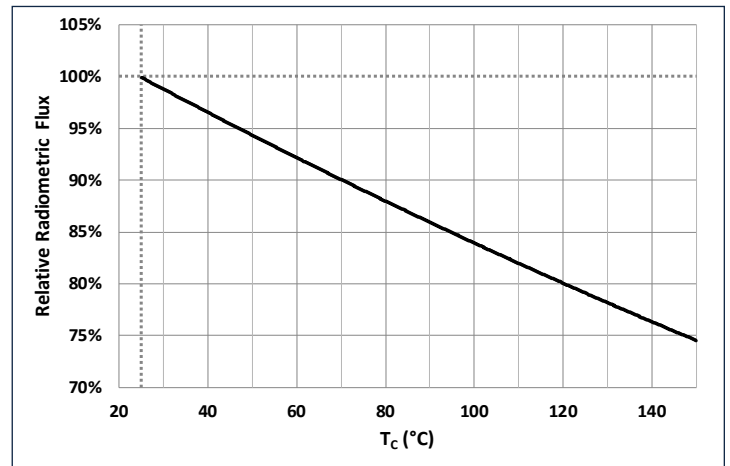

Forward Voltage

Forward current: $V_f = V(I_f), T_c = 25^\circ\text{C}$

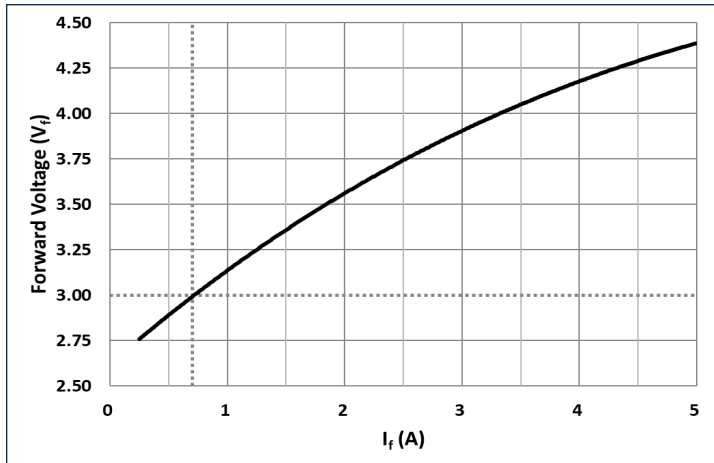

Temperature: $\Delta V_f = V(T_c) - V(25^\circ\text{C}), I_f = 0.7\text{ A}$

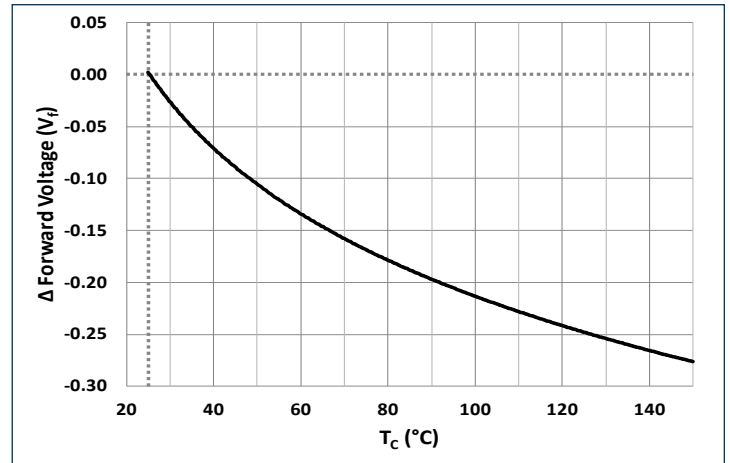

Dominant Wavelength Shift

Forward current: $\Delta\lambda_d = \lambda_d(I_f) - \lambda_d(0.7\text{ A}), T_c = 25^\circ\text{C}$

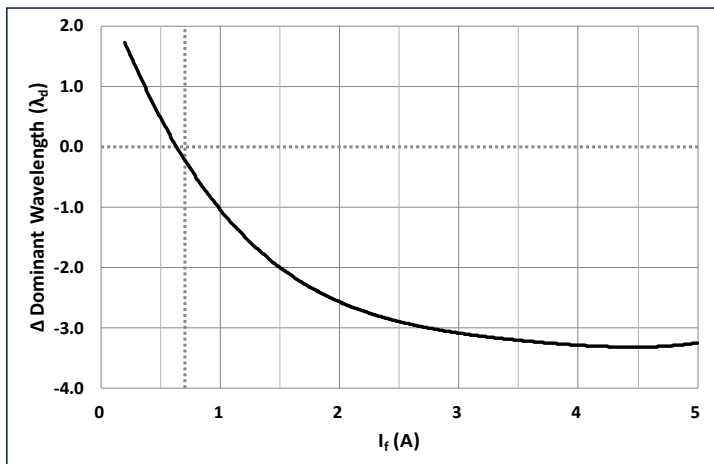

Temperature: $\Delta\lambda_d = \lambda_d(T_c) - \lambda_d(25^\circ\text{C}), I_f = 0.7\text{ A}$

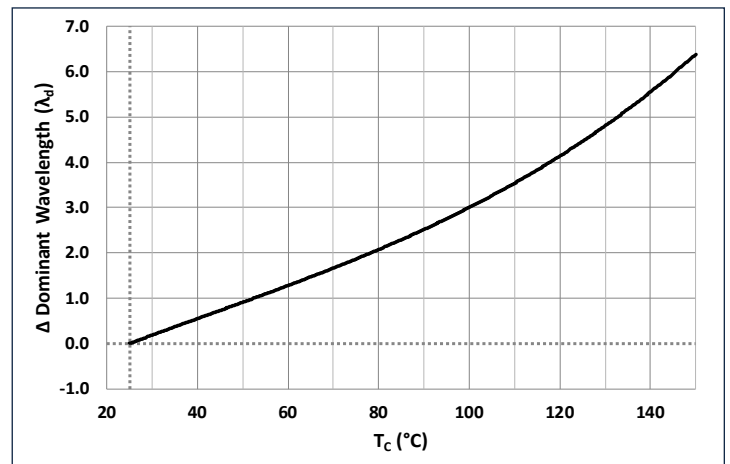



Angular Distribution and Typical Spectrum

Angular Intensity Distribution

$$I_{\text{ref}} = f(\Phi); T_c = 25^\circ\text{C}$$

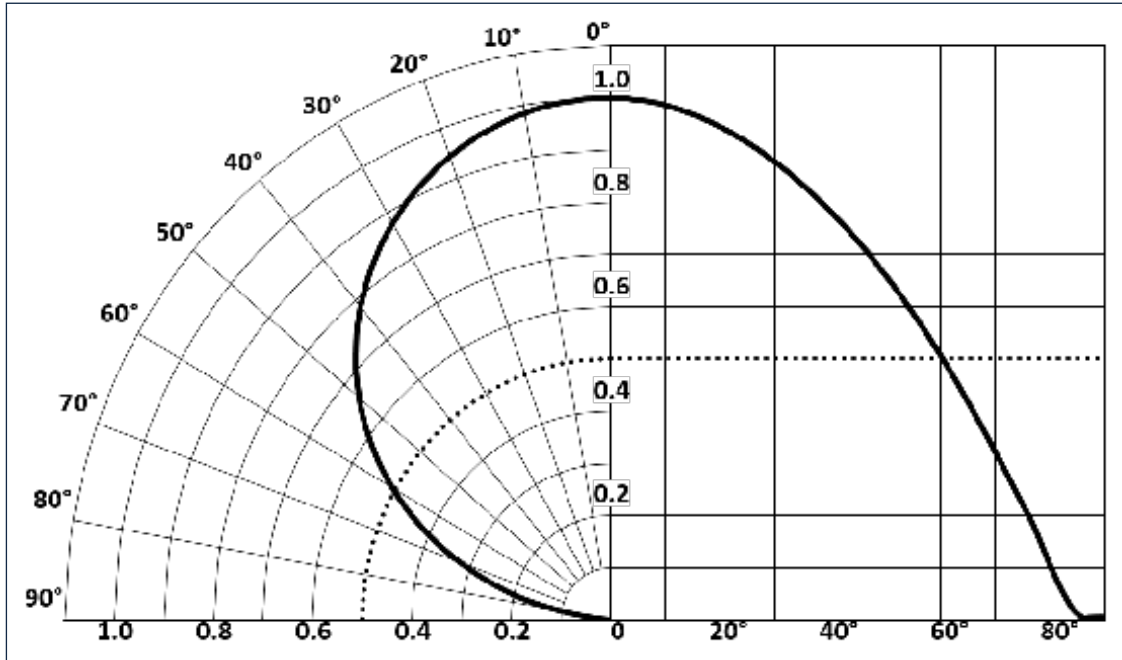

Typical Spectrum

$$\Phi_{\text{ref}} = f(\lambda); I_f = 0.7 \text{ A}; T_c = 25^\circ\text{C}$$

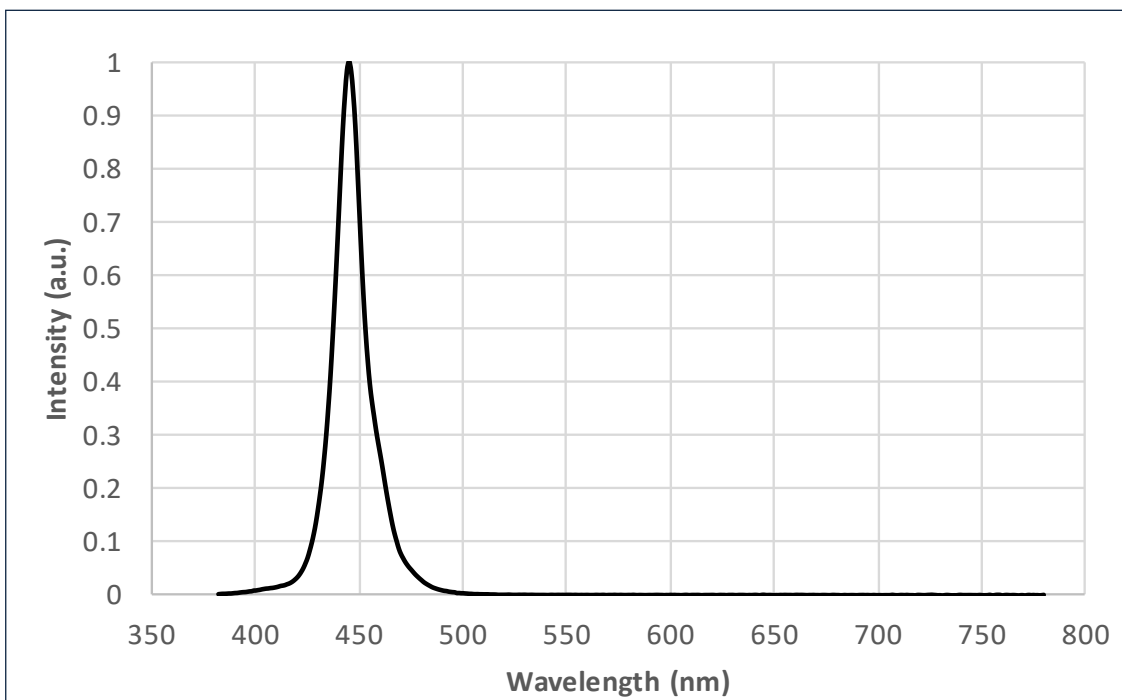



Soldering Profile

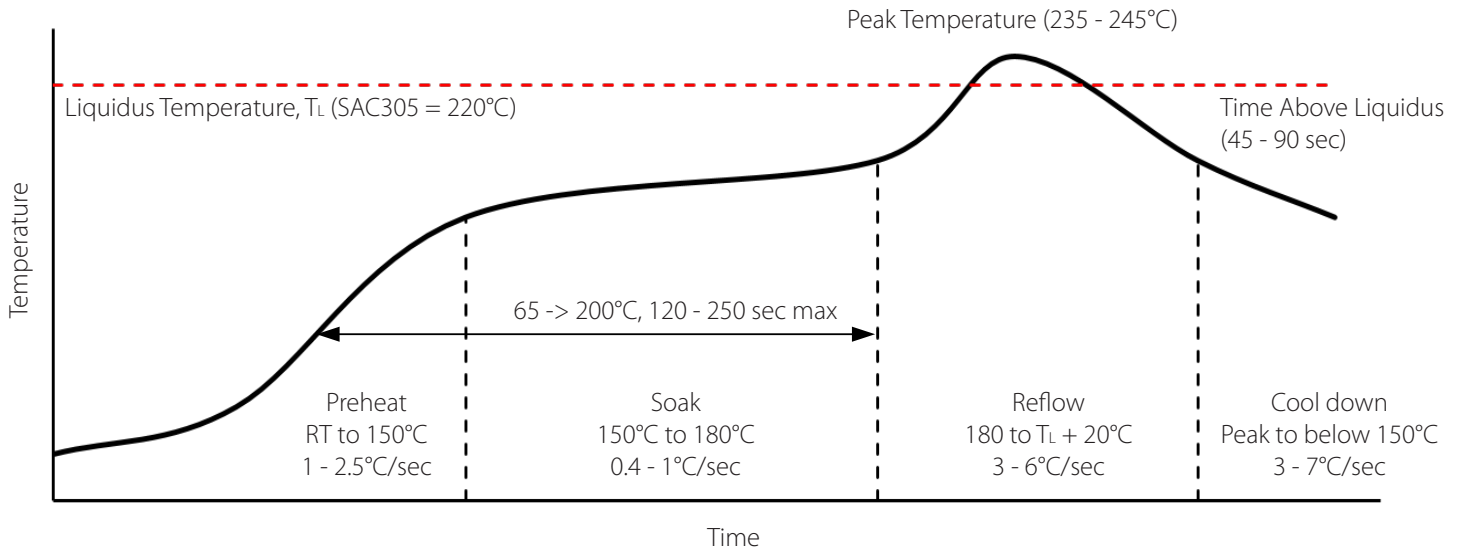

SMT Rework Guideline	Manual Hotplate Reflow	Hot Air Gun Reflow
Heating Time	< 60 sec	
Hotplate Temperature	< 245°C	< 150°C

Note:

- Product complies to Moisture Sensitivity Level 3 (MSL 3).
- The numbers in the table are specific to SAC305. Luminus recommends using an SAC305 solder paste with a no-clean flux for RoHS compliant products.
- During the pick and place process, ensure the pick-up tool does not touch any die components.
- Use of a multi-zone IR reflow oven with a nitrogen blanket is recommended.
- Time-temperature profile of the reflow process showing the four functional profile zones are defined in IPC-7801. Temperature is referenced to the center of the PCB.
- Luminus recommends to use the solder paste data sheet information as a starting point in time-temperature process development.
- These are general guidelines. Consult the solder paste manufacturer's datasheet for guidelines specific to the alloy and flux combination used in your application.
For more information, please refer to:
<https://luminusdevices.zendesk.com/hc/en-us/articles/360060306692-How-do-I-Reflow-Solder-Luminus-SMD-Components->
- For any technical questions about soldering process, please contact Luminus at techsupport@luminus.com.



Mechanical Dimensions

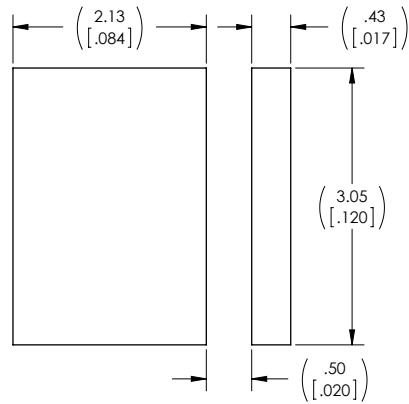
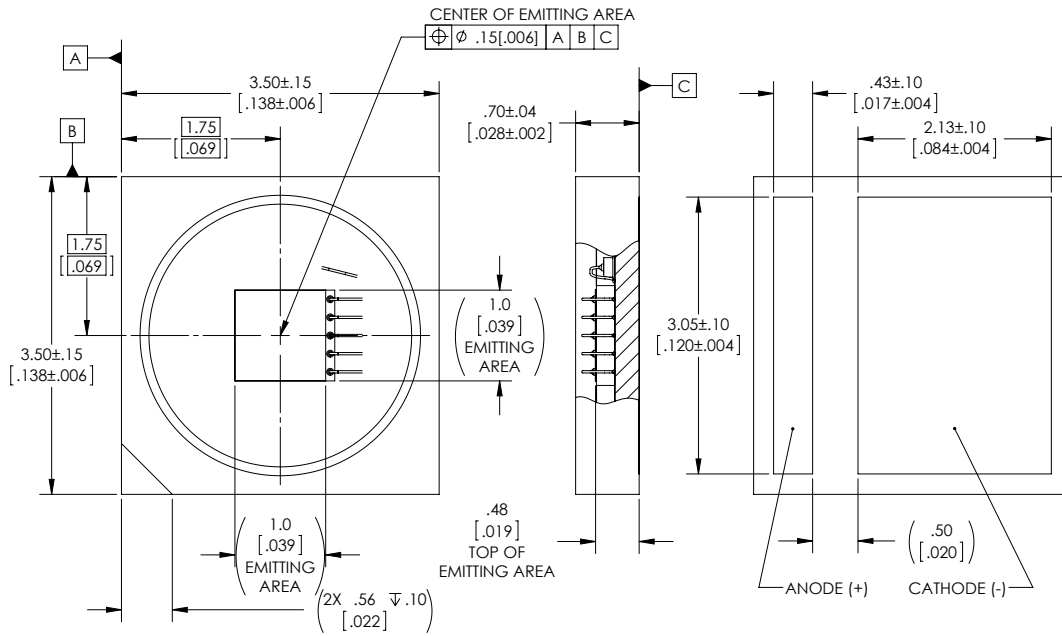

RECOMMENDED SOLDER PAD LAYOUT



Mechanical Dimensions

Starboard dimensions

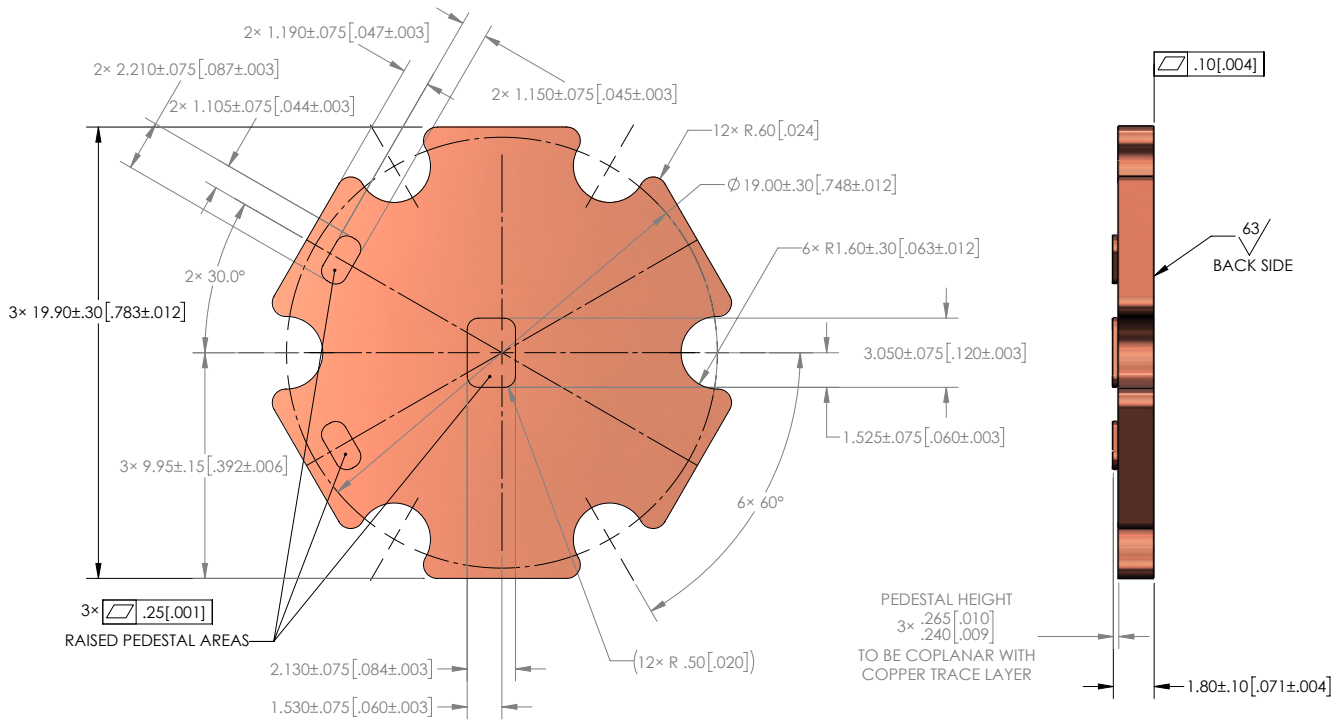
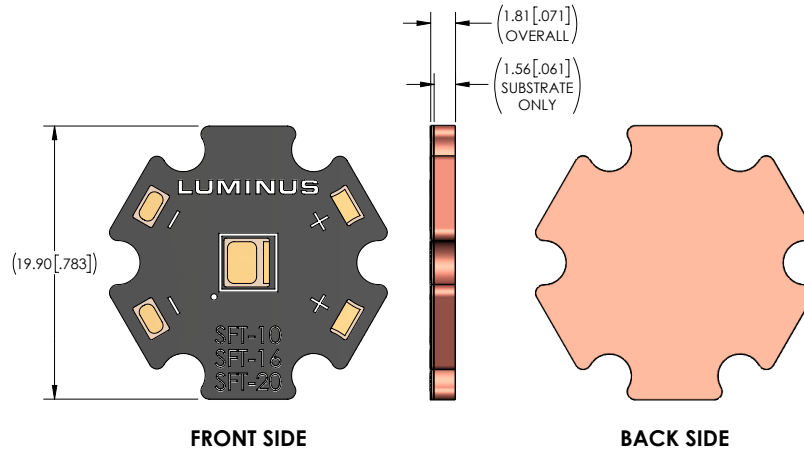

BASE WITH RAISED PEDESTAL AREAS



Tape and Reel Outline

Shipping Reel Outline

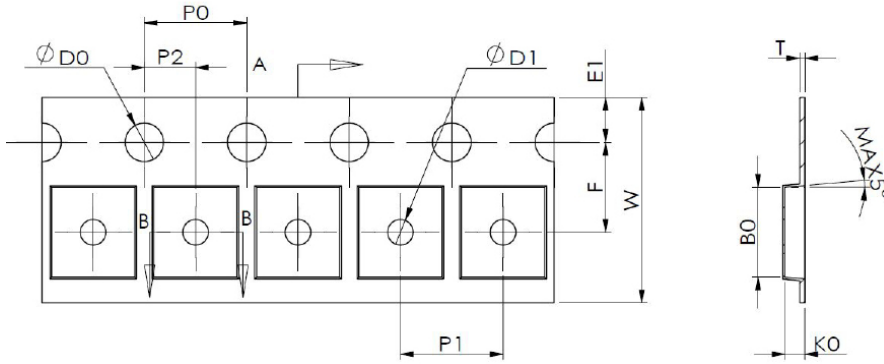

Parameter	Dimension (mm)
B0	4.00 +/- 0.10
K0	1.20 +/- 0.10
P0	4.00 +/- 0.10
P1	8.00 +/- 0.10
P2	2.00 +/- 0.05
T	0.30 +/- 0.05
E1	1.75 +/- 0.10
F	5.50 +/- 0.05
D0	1.55 +/- 0.05
D1	1.55 +/- 0.05
W	12.00 +/- 0.10

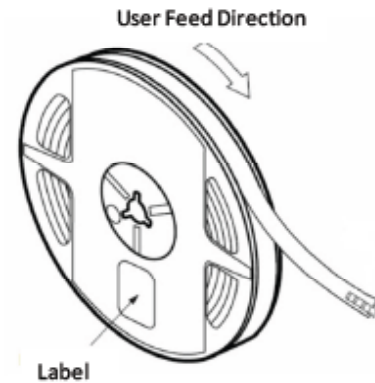
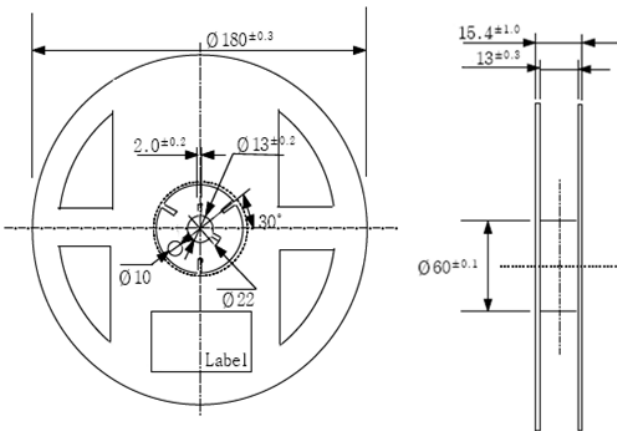

Note:

1. The quantity per reel is not orderable.
2. Minimum order quantity: 500 pcs.

Parameter	Quantity (pcs)
Pieces per reel	250
	500



Tape and Reel Outline

Reel Package

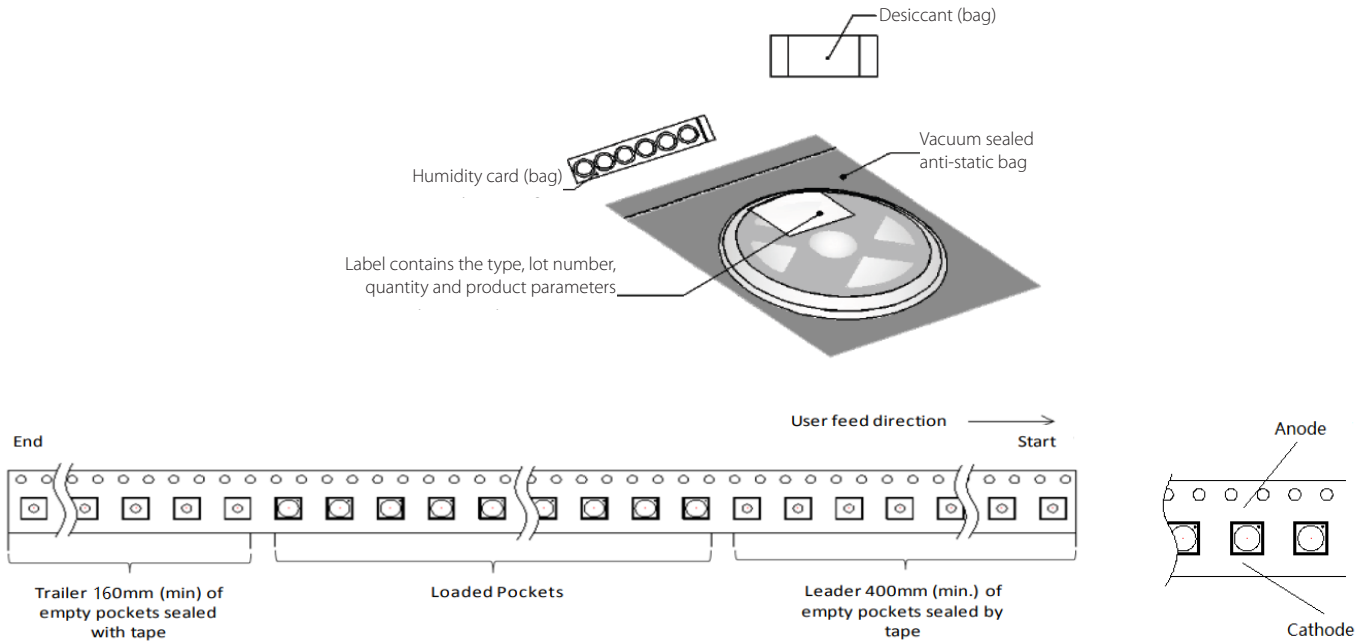

Box Packaging Information

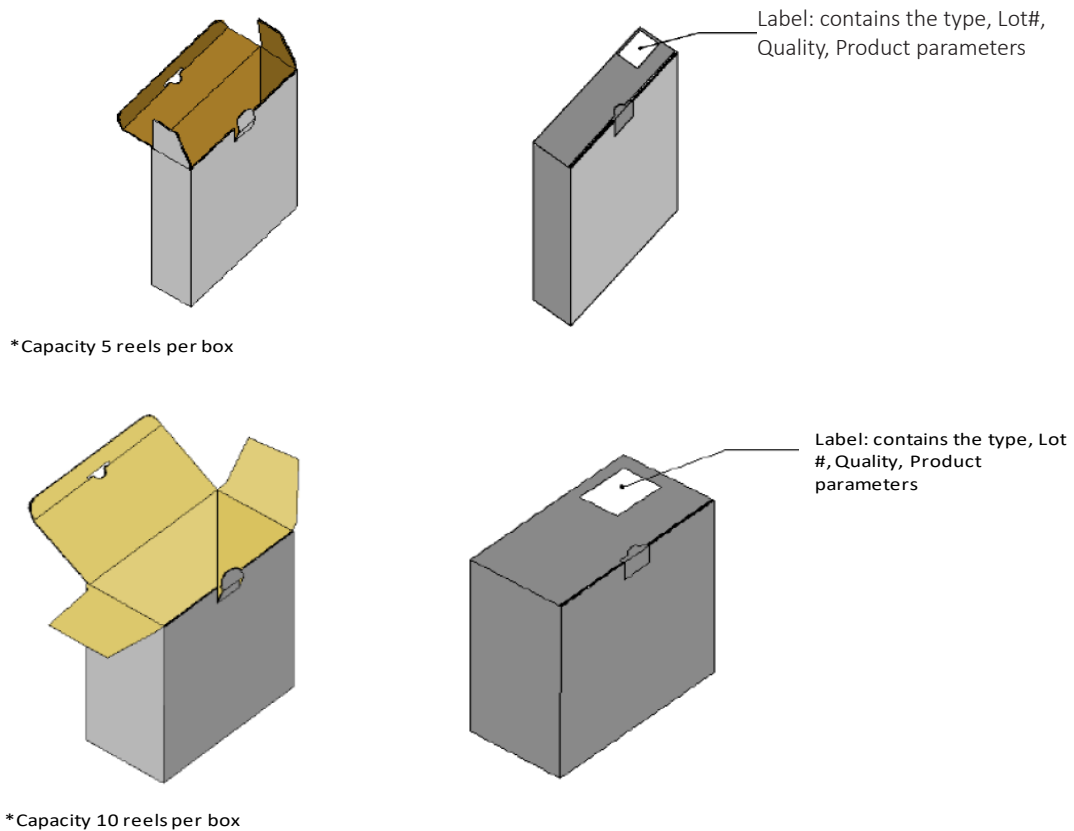



Shipping Label

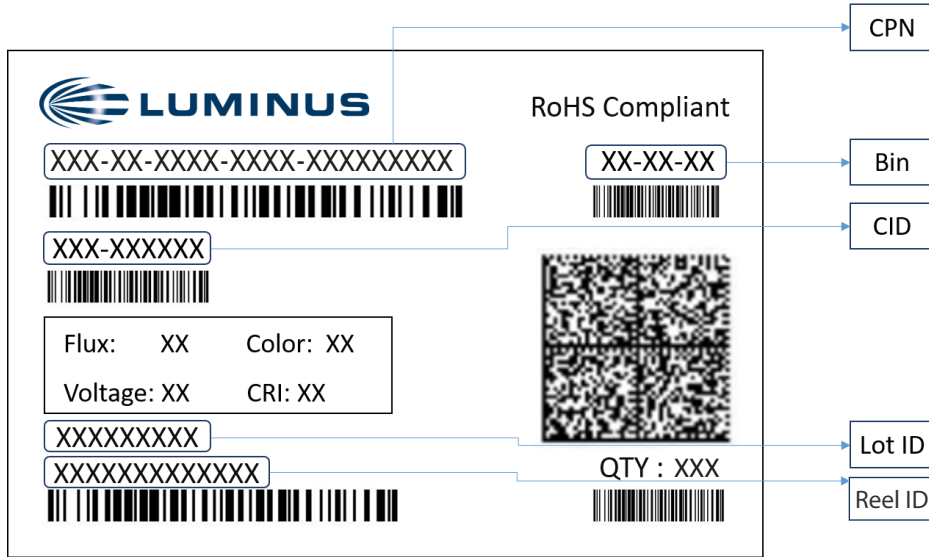

Label Fields:

- CPN: Luminus ordering part number
- CID: Customer's part number
- QTY: Quantity of devices in pack
- Flux: Bin as defined on page 3
- Voltage: NA
- Color: Bin as defined on page 3
- CRI: NA

Packing Configuration:

- Maximum of 500 devices per reel
- Partial reel may be shipped
- Each pack is enclosed in anti-static bag
- Shipping label is placed on top of each pack



Notes

Static Electricity

This product is sensitive to static electricity, and care should be taken when handling them. Static electricity or surge voltage will damage the LEDs. It is recommended to wear an anti-electrostatic wristband or anti-electrostatic gloves when handling the LEDs. All devices, equipment and machinery must be properly grounded. It is recommended that measures be taken to isolate LED processing equipment from potential sources of voltage surges.

Reference: APN-002815 Electrical Stress Damage to LEDs and How to Prevent It

Eye Safety

According to the test specification risk group IEC 62471: 2006-Non-GLS under 0.7 A, this product complies to Risk group 2 (RG2) Moderate risk.

Do not stare at operating lamp, may be harmful to the eyes.

For more information, please refer to: <https://luminusdevices.zendesk.com/hc/en-us/articles/10532958752397>



Revision History

Rev	Date	Description of Change
01	11/20/2023	Initial release as single color SFT-10. Replacing SFT-10 RGB datasheet PDS-002823.