

SFT-12R-WG (CRI > 90)

High Power White LEDs

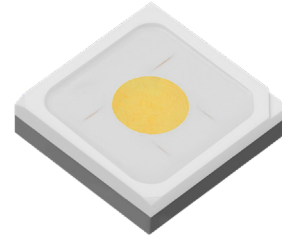

Features

With Luminus' advanced chip and packaging technologies, SFT-12R-W maximizes the Candela/Lumen K-Factor for high optical performance in directional lighting:

- A small emitter enables high intensity, long beam distance and small optics.
- A patented round emitter, in comparison with a square emitter, enables better uniformity and higher intensity in beam spots.
- A flat window, in comparison with a domed cover, allows the optics to be closer to the emitter to achieve higher intensity and longer beam distance.

In addition, Luminus phosphor-on-chip technology's high uniformity of color over radiation angle enables superior beam spot light quality.

- Package Size: 3535
- Maximum Drive Current: 3 A
- Color Temperature: 2700K - 5700K
- Color Rendering Index: > 90
- Low thermal resistance: 1.7°C/W
- ANSI-compatible chromaticity bins
- Electrically isolated thermal path
- 8 kV HBM ESD rating per ANSI/ESDA/JEDEC JS-001

Applications

- Stadium and Sports Field Lighting
- Roadway and Street Lighting
- Outdoor Area Lighting
- Landscape Lighting
- Garage and Canopy Lights
- High / Low Bay Industrial Lighting
- Track Light
- Spotlight
- Wall Washer
- Task Light

Table of Contents

Ordering Information.	2
Binning Structure.	3
Absolute Maximum Ratings	7
Characteristics	7
Angular Distribution and Typical Spectrum.	10
Mechanical Dimensions.	12
Soldering Profile.	13
Tape and Reel Outline.	14
Shipping Label	15
Packaging	16
Notes	17





Ordering Information

Ordering Part Numbers¹

CRI	CCT	Luminous Flux		Ordering Part Number		
		Minimum Flux Bin ¹	Minimum Flux ²	Chromaticity Bin Kit 2-Step Ellipse ³	Chromaticity Bin Kit 3-Step Ellipse ³	Chromaticity Bin Kit ANSI Centers ³
> 90	2700K	C2	172 lm	SFT-12R-WG27-AV2-C227E2	SFT-12R-WG27-AV2-C227E3	-
	3000K	C3	182 lm	SFT-12R-WG30-AV2-C330E2	SFT-12R-WG30-AV2-C330E3	-
		C4	192 lm	SFT-12R-WG30-AV2-C430E2	SFT-12R-WG30-AV2-C430E3	-
	3500K	C4	192 lm	SFT-12R-WG35-AV2-C435E2	SFT-12R-WG35-AV2-C435E3	-
	4000K	C5	202 lm	SFT-12R-WG40-AV2-C540E2	SFT-12R-WG40-AV2-C540E3	-
	5000K	C5	202 lm	-	SFT-12R-WG50-AV2-C550E3	SFT-12R-WG50-AV2-C5502
	5700K	C5	202 lm	-	SFT-12R-WG57-AV2-C557E3	SFT-12R-WG57-AV2-C5572
C6		214 lm	-	SFT-12R-WG57-AV2-C657E3	SFT-12R-WG57-AV2-C6572	

Part Number Nomenclature

SFT	12R	W<xyy>	AV2	<ffcccc>
Product Family	Chip Area	Color	Package Configuration	Bin Kit
S: Surface Mount F: Flat Window T: Single Emitter	12: 1.2 mm ² R: Round Shape	W: White <x> CRI Category Code G: CRI>90 <yy> Color Temperature 27: 2700K 57: 5700K	AV2: 3535 package code	<ff> Minimum Flux Bin, see 'Luminous Flux Bins' table for details <cccc> Chromaticity Bin Kit, see 'Chromaticity Bin Kit Codes' table for details

Notes:

- The Ordering Part Number specifies the Minimum Flux Bin in shipment; higher flux bins may be shipped without advance notice. Please refer to 'Luminous Flux Bins' table for details of all flux bins.
- Product test condition: $I_f = 700 \text{ mA}$, $T_j = 85^\circ\text{C}$.
- Shipments always adhere to the color bins specified in each Chromaticity Bin Kit. See 'Chromaticity Bin Kit Codes' table for the color bins included in each bin kit.



Binning Structure

Luminous Flux Bins^{1,2}

Flux Bin	Binning @ 700 mA			Correlated Minimum Flux (lm) @ $T_j = 85^\circ\text{C}^2$			
	$T_j = 85^\circ\text{C}$		$T_j = 25^\circ\text{C}$				
	Minimum Flux (lm)	Maximum Flux (lm)	Minimum Flux (lm)	1000 mA	1500 mA	2000 mA	3000 mA
C1	162	172	181	217	296	366	476
C2	172	182	193	230	315	389	506
C3	182	192	204	244	333	411	535
C4	192	202	215	257	351	434	564
C5	202	214	226	271	370	457	594
C6	214	226	240	287	392	484	629
C7	226	238	253	303	414	511	664

Forward Voltage Bins³

Voltage Bin	Binning @ 700 mA, $T_j = 85^\circ\text{C}$	
	Minimum Voltage (V)	Maximum Voltage (V)
VJ	2.7	2.9
VK	2.9	3.1

Notes:

- LEDs are measured at 25°C ambient temperature with 700 mA 20 ms single pulse. The measured values are correlated to values at 85°C junction temperature (T_j). Luminus maintains a $\pm 6\%$ tolerance on flux measurement.
- Flux values at other junction temperature (T_j) and/or forward current conditions are calculated and for reference only.
- Individual voltage bins are not orderable.



Binning Structure

Chromaticity Binning Coordinates (2-Step & 3-Step Ellipse)

CCT	Center Point		2-Step Ellipse		3-Step Ellipse		Angle
	CIE _x	CIE _y	a	b	a	b	
2700K	0.4582	0.4099	0.0054	0.0028	0.0081	0.0042	53.42°
3000K	0.4338	0.4030	0.0056	0.0027	0.0083	0.0041	53.20°
3500K	0.4080	0.3916	0.0062	0.0028	0.0093	0.0041	54.00°
4000K	0.3825	0.3798	0.0063	0.0027	0.0094	0.0040	53.43°
5000K	0.3447	0.3553	-		0.0081	0.0035	59.60°
5700K	0.3287	0.3417			0.0072	0.0032	59.09°

Chromaticity Binning Coordinates (ANSI Centers)

CCT	Bin	CIE _x	CIE _y	Bin	CIE _x	CIE _y	Bin	CIE _x	CIE _y	Bin	CIE _x	CIE _y
5000K	DA	0.3396	0.3511	DB	0.3456	0.3616	DC	0.3456	0.3616	DD	0.3446	0.3495
		0.3371	0.3490		0.3463	0.3687		0.3463	0.3687		0.3440	0.3427
		0.3366	0.3369		0.3376	0.3616		0.3551	0.3760		0.3515	0.3487
		0.3440	0.3427		0.3371	0.3490		0.3533	0.3620		0.3533	0.3620
		0.3446	0.3495		0.3396	0.3511		0.3498	0.3593		0.3498	0.3593
5700K	CA	0.3241	0.3373	CB	0.3241	0.3373	CC	0.3290	0.3469	CD	0.3333	0.3457
		0.3215	0.3350		0.3215	0.3350		0.3290	0.3538		0.3371	0.3490
		0.3222	0.3243		0.3207	0.3462		0.3376	0.3616		0.3366	0.3369
		0.3290	0.3300		0.3290	0.3538		0.3371	0.3490		0.3290	0.3300
		0.3289	0.3369		0.3290	0.3469		0.3333	0.3457		0.3290	0.3370



Binning Structure

Chromaticity Binning Diagram (Warm White)^{1,2,3}

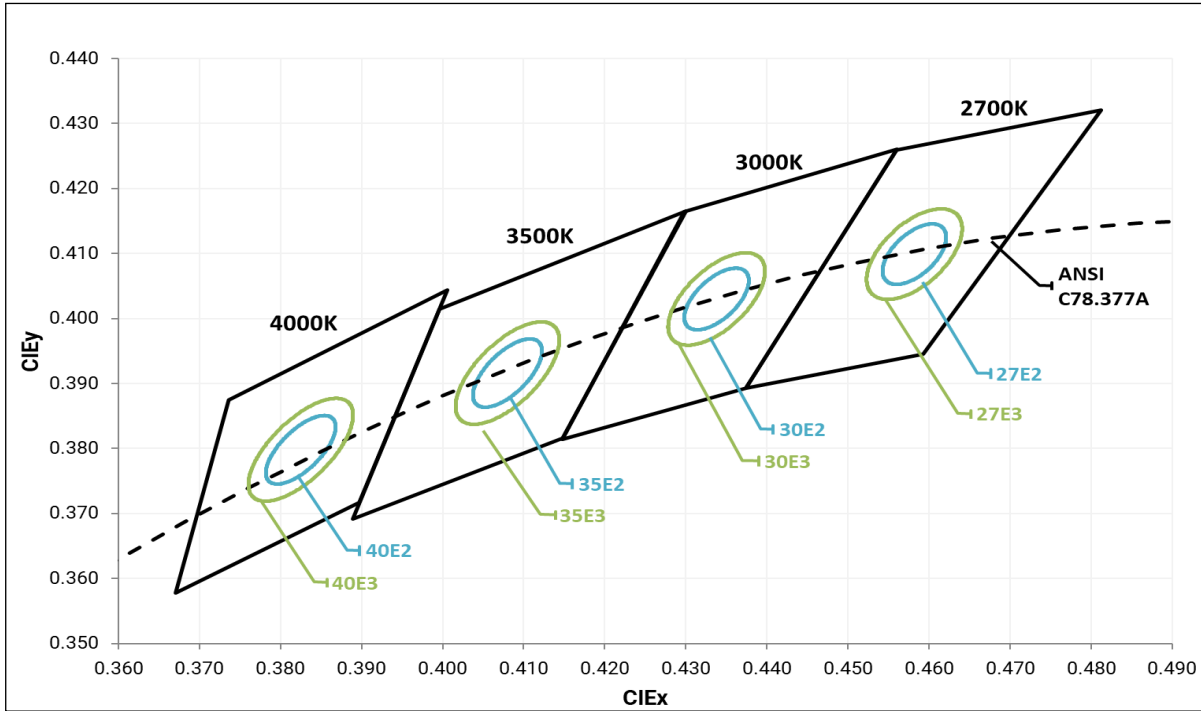

Chromaticity Binning Diagram (Cool White)^{1,2,3}

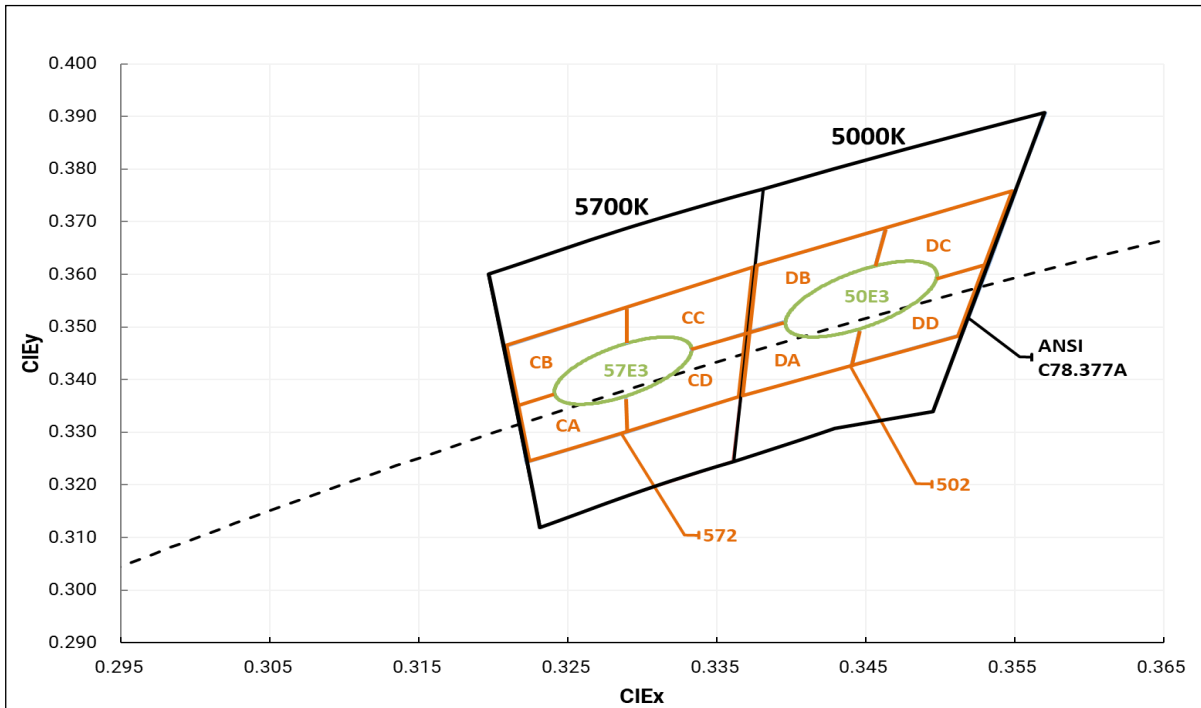



Binning Structure

Chromaticity Bin Kit Codes

CCT	2-Step Ellipse		3-Step Ellipse		ANSI Centers	
	Bin Kit Code	Chromaticity Bins	Bin Kit Code	Chromaticity Bins	Bin Kit Code	Chromaticity Bins
2700K	27E2	27E2	27E3	27E2, 27E3		
3000K	30E2	30E2	30E3	30E2, 30E3		
3500K	35E2	35E2	35E3	35E2, 35E3		
4000K	40E2	40E2	40E3	40E2, 40E3		
5000K			50E3	50E3	502	50E3, DA, DB, DC, DD
5700K			57E3	57E3	572	57E3, CA, CB, CC, CD

Notes:

1. LED chromaticity is measured and binned at 25°C ambient temperature with 700 mA 20 ms single pulse.
2. Luminus maintains a tolerance of ± 0.005 on Chromaticity (CIEx, CIEy) measurement.
3. Chromaticity binning is based on CIEx and CIEy coordinates only. CCT values shown in the datasheet are for informational purposes and do not represent binning criteria.



Absolute Maximum Ratings

Parameter		Symbol	Values	Unit
Forward Current	Minimum	$I_{f \min}$	0.1	A
	Maximum	$I_{f \max}$	3.0	
Surge Current (t < 10 ms, Duty Cycle < 10%)		I_s	4.0	
Reverse Voltage (@ $I_f = 10 \text{ mA}$)		V_r	5	V
Power Dissipation		P_D	11	W
Junction Temperature		T_j	150	°C
Operating Temperature Range		T_{opr}	-40 to 100	
Storage Temperature Range		T_{stg}	-40 to 100	
ESD withstand Voltage ANSI/ESDA/JEDEC JS-001 (HBM)		V_{ESD}	8	kV
ESD withstand Voltage ANSI/ESDA/JEDEC JS-002 (CDM)		V_{CDM}	1	

Characteristics

Parameter ($I_f = 700 \text{ mA}$, $T_j = 85^\circ\text{C}$)		Symbol	Value	Unit
Color Rendering Index ¹		CRI	> 90	
Forward Voltage	Minimum	$V_{f \min}$	2.7	V
	Typical	$V_{f \text{ typ}}$	2.9	
	Maximum	$V_{f \max}$	3.1	
Viewing Angle ²	2700K - 4000K	$2\theta_{1/2}$	115	°
	5000K - 5700K		117	
Temperature Coefficient of Voltage		$\Delta V_f / \Delta T$	-1.2	mV/°C
Electrical Thermal Resistance (Junction to Solder Point) ³		$R_{th \text{ JS elec}}$	1.7	°C/W

Notes:

- Luminus maintains a tolerance of ± 2 on Color Rendering Index (CRI) measurement.
- Please contact Luminus Sales regarding the details of Viewing Angle vs Chromaticity.
- Thermal measurements are in accordance with JEDEC 51-14.



Relative Luminous Flux vs Forward Current

$T_j = 85^\circ\text{C}$ (2700K - 4000K)

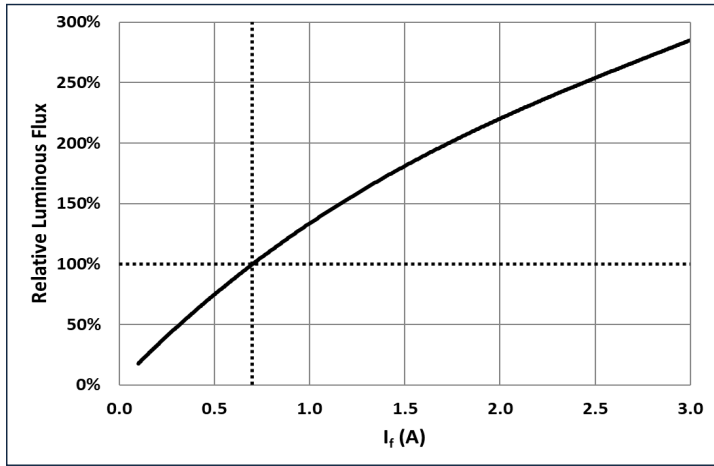

Relative Luminous Flux vs Temperature

$I_f = 0.7\text{ A}$ (2700K - 4000K)

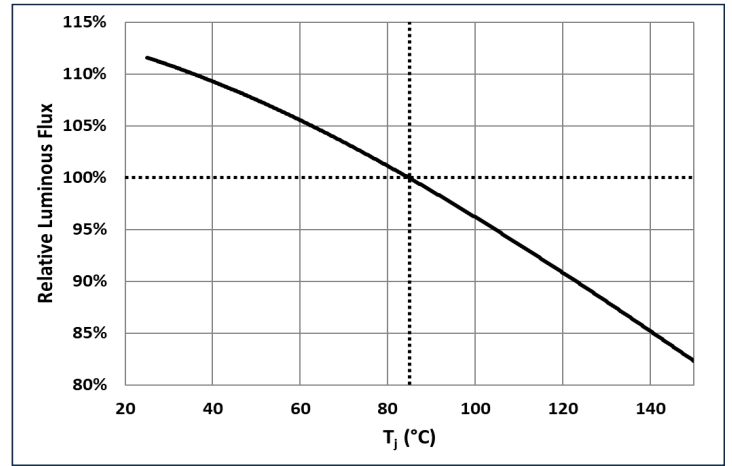

Forward Voltage vs Forward Current

$T_j = 85^\circ\text{C}$ (2700K - 4000K)

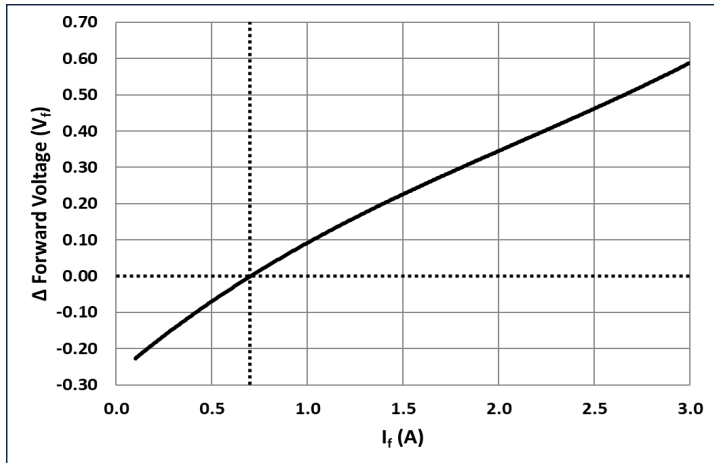

Forward Voltage vs Temperature

$I_f = 0.7\text{ A}$ (2700K - 4000K)

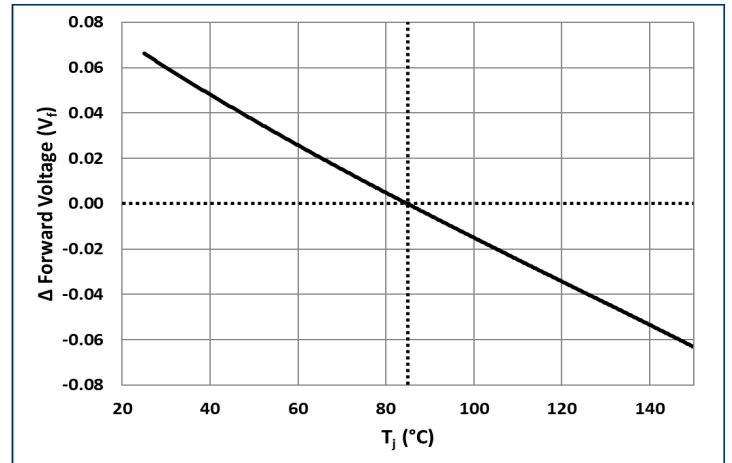

Relative Chromaticity vs Forward Current

$T_j = 85^\circ\text{C}$ (2700K - 4000K)

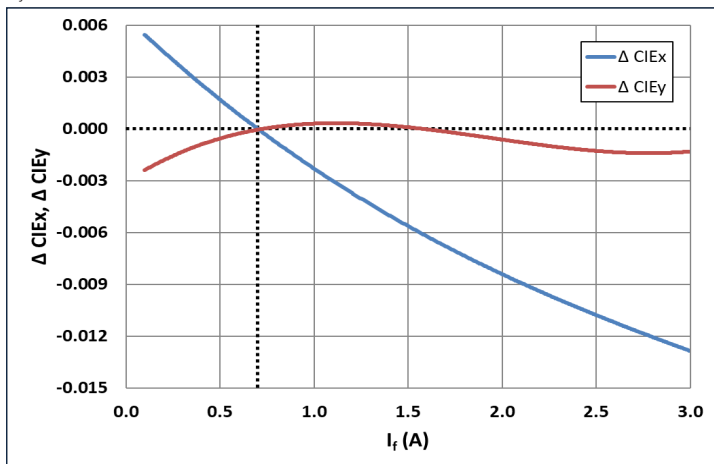

Relative Chromaticity vs Temperature

$I_f = 0.7\text{ A}$ (2700K - 4000K)

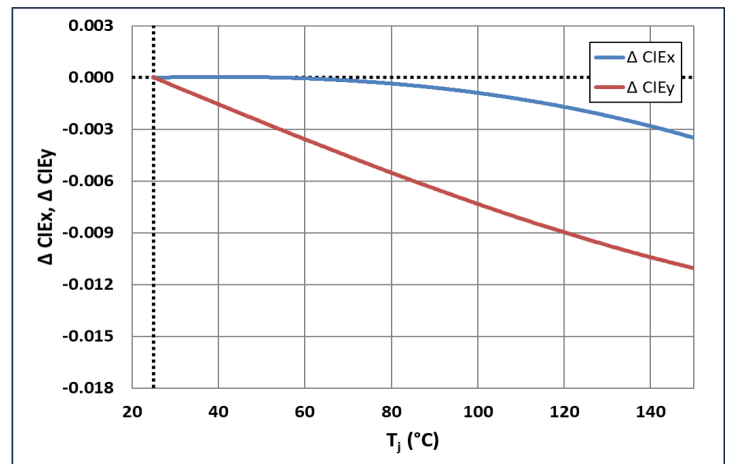



Relative Luminous Flux vs Forward Current

$T_j = 85^\circ\text{C}$ (5000K - 5700K)

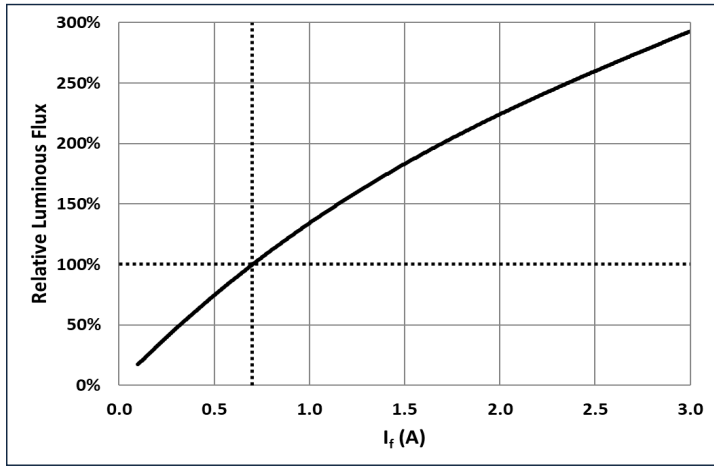

Relative Luminous Flux vs Temperature

$I_f = 0.7\text{ A}$ (5000K - 5700K)

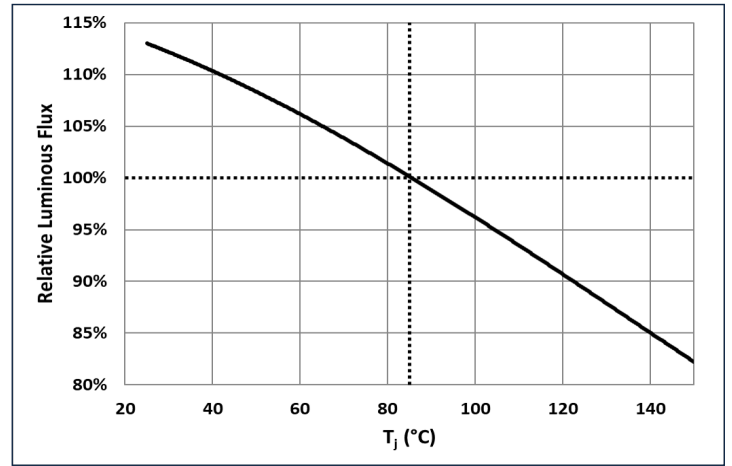

Forward Voltage vs Forward Current

$T_j = 85^\circ\text{C}$ (5000K - 5700K)

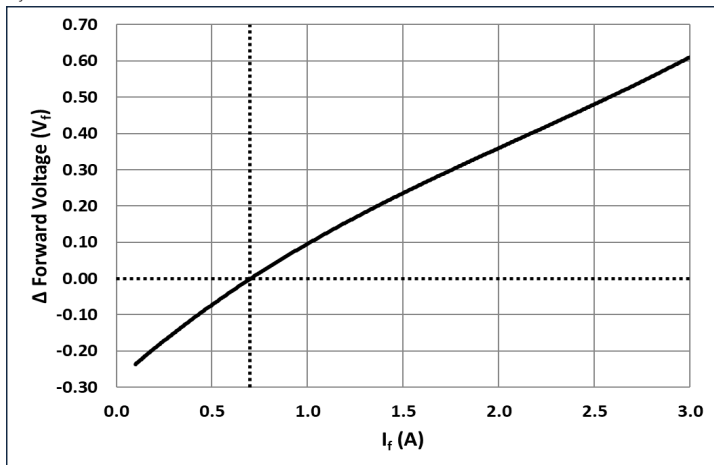

Forward Voltage vs Temperature

$I_f = 0.7\text{ A}$ (5000K - 5700K)

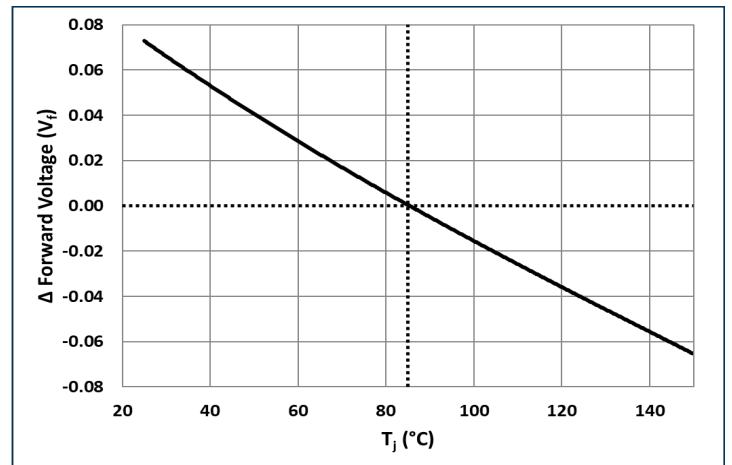

Relative Chromaticity vs Forward Current

$T_j = 85^\circ\text{C}$ (5000K - 5700K)

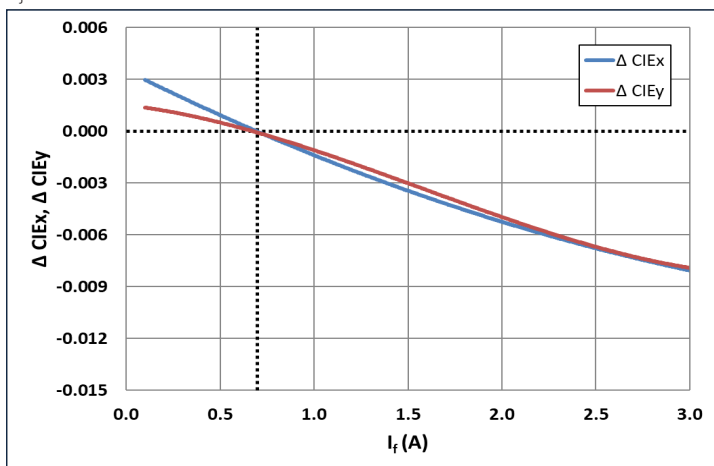

Relative Chromaticity vs Temperature

$I_f = 0.7\text{ A}$ (5000K - 5700K)

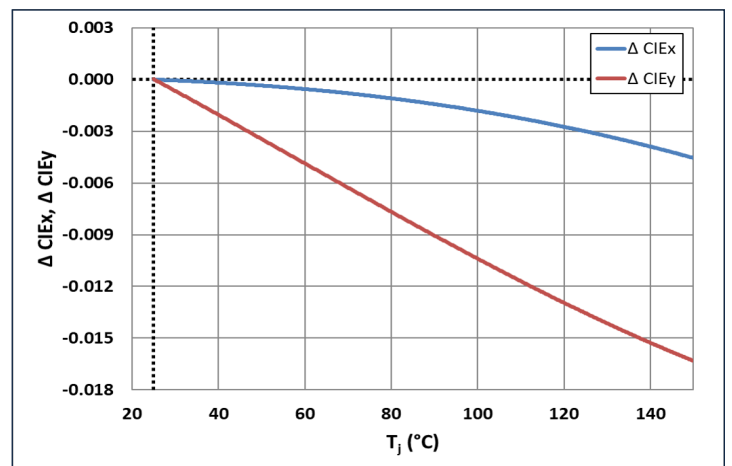



Angular Distribution and Typical Spectrum

Angular Distribution (2700K - 4000K)

$I_f = 0.7 \text{ A}; T_j = 25^\circ\text{C}$

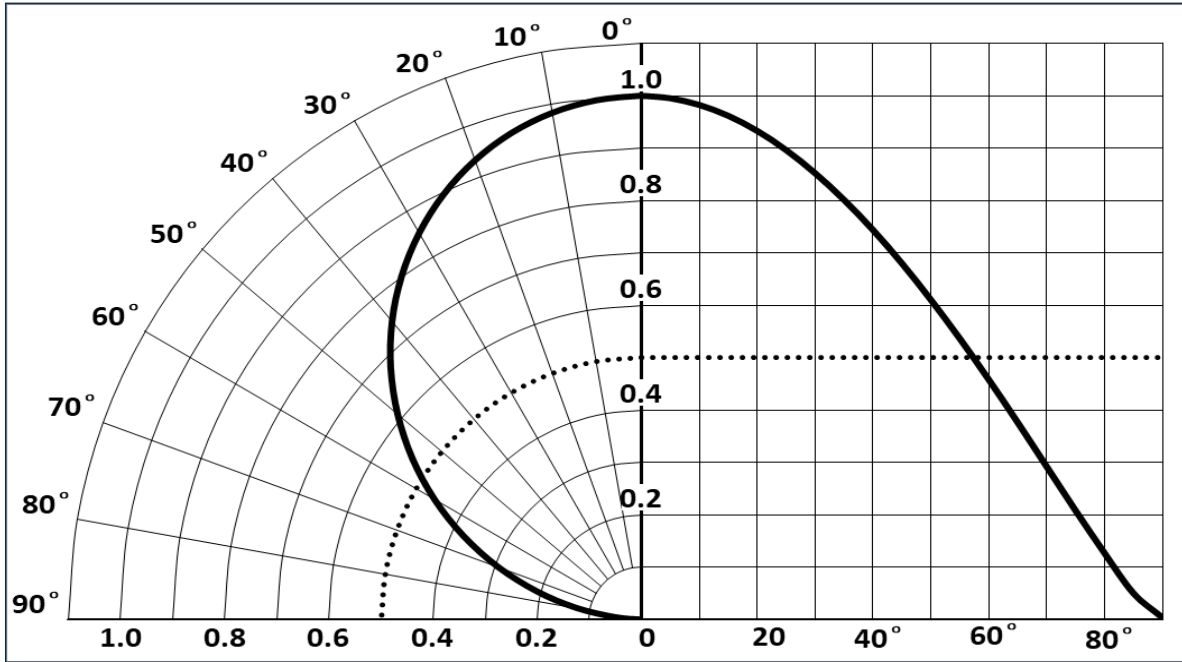

Relative Spectral Power Distribution (2700K - 4000K)

$I_f = 0.7 \text{ A}; T_j = 85^\circ\text{C}$

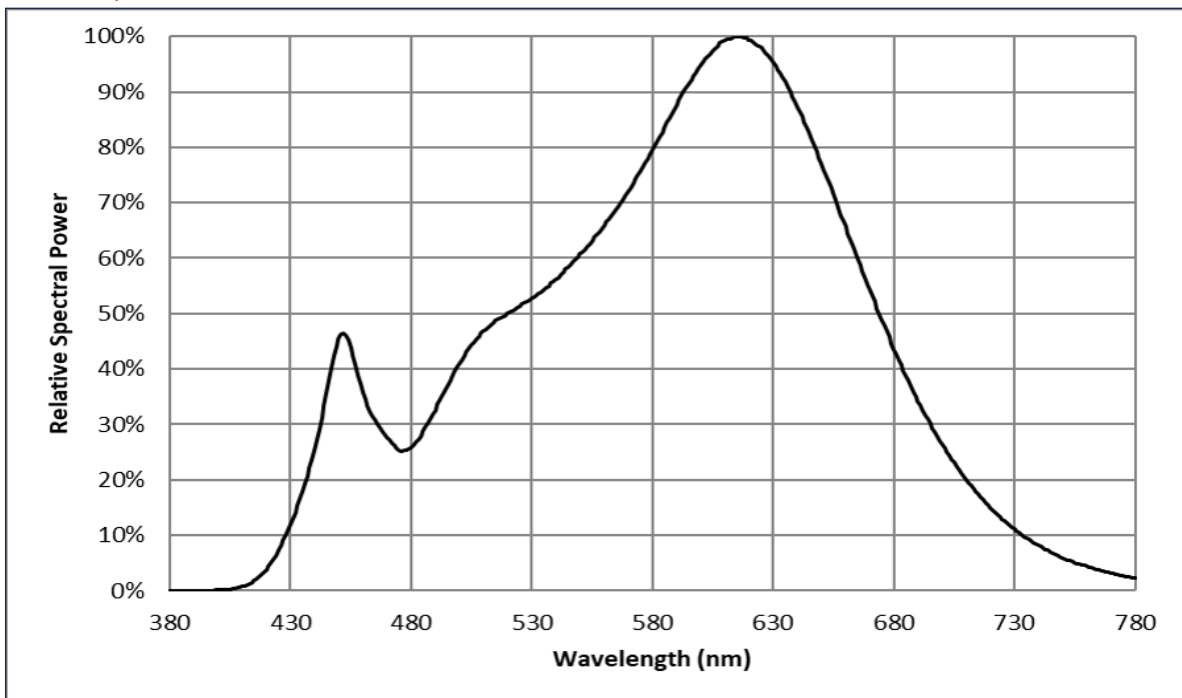



Angular Distribution and Typical Spectrum

Angular Distribution (5000K - 5700K)

$I_f = 0.7 \text{ A}; T_j = 25^\circ\text{C}$

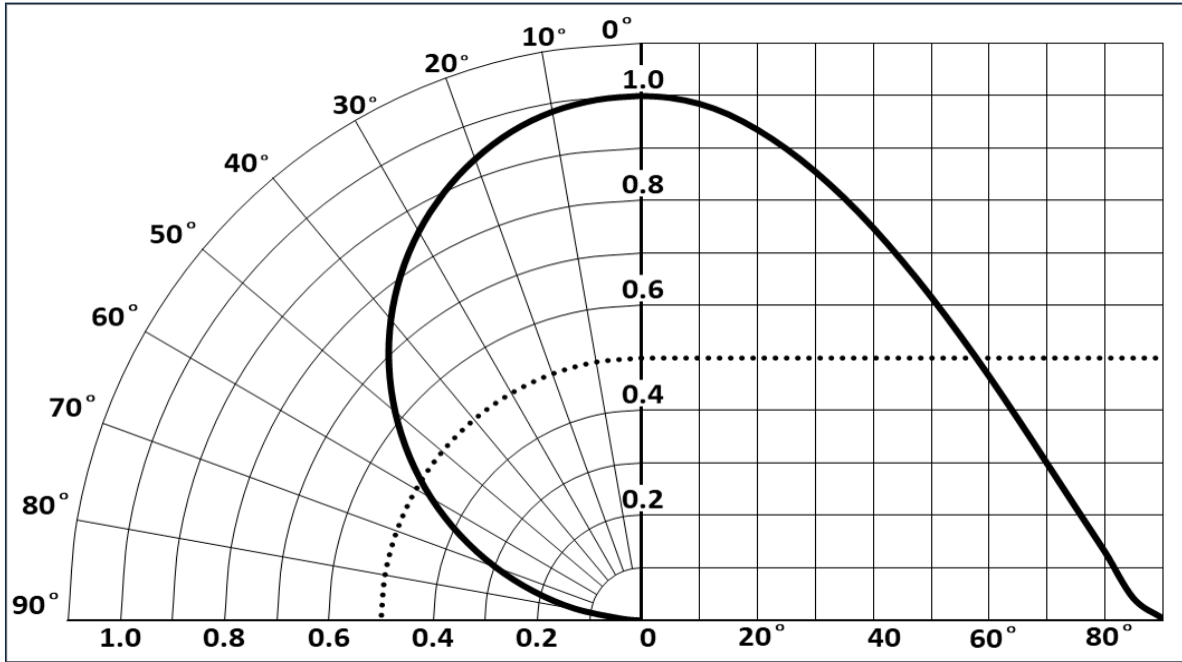

Relative Spectral Power Distribution (5000K - 5700K)

$I_f = 0.7 \text{ A}; T_j = 85^\circ\text{C}$

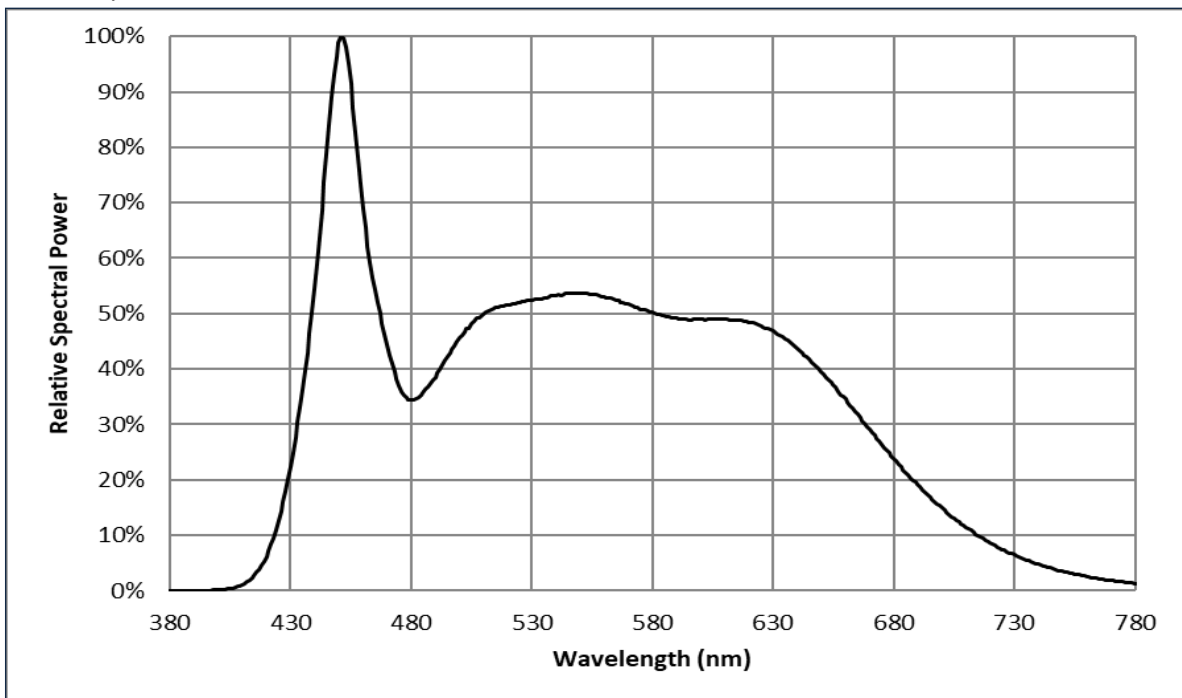



Mechanical Dimensions¹

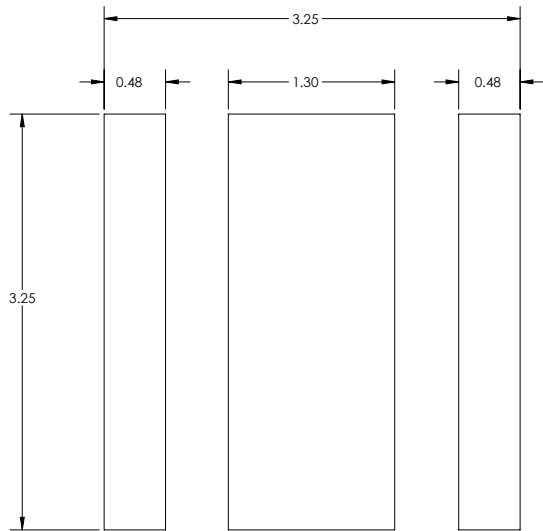
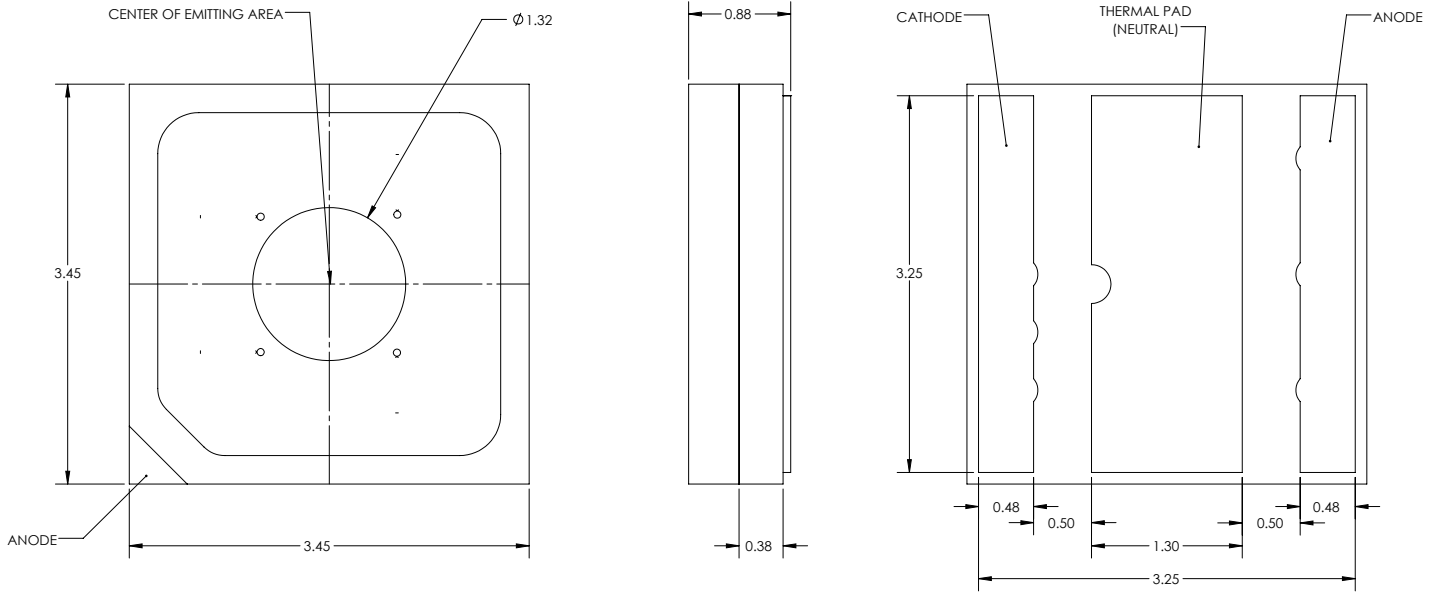

RECOMMENDED PCB SOLDER PAD DESIGN

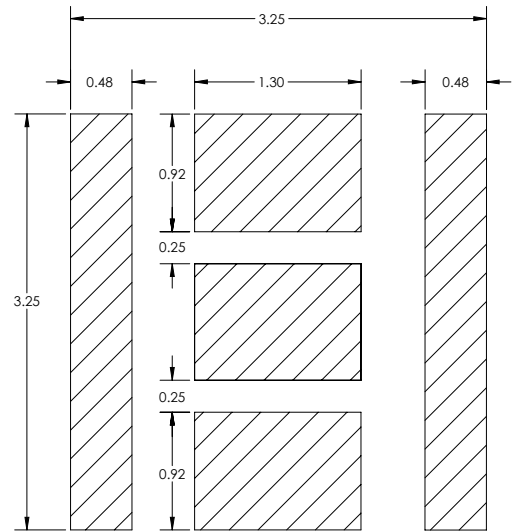

RECOMMENDED STENCIL PATTERN DESIGN

Note:

1. All dimensions are in millimeter ± 0.13 mm.



Soldering Profile

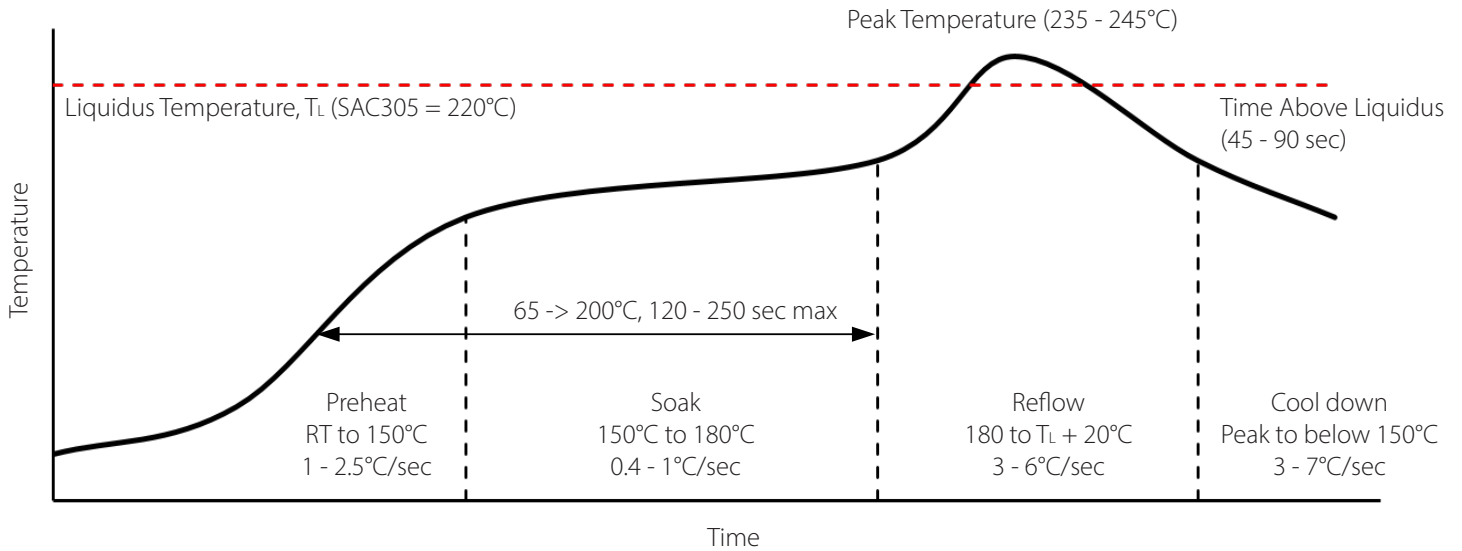

SMT Solder Rework Temperature Guidelines

Parameter	Manual Hotplate Reflow	Hot Air Gun Reflow
Heating Time	< 60 sec	
Hotplate Temperature	< 245°C	< 150°C

Notes:

- Product complies to Moisture Sensitivity Level 3 (MSL 3).
- The numbers in the table are specific to SAC305. Luminus recommends using an SAC305 solder paste with a no-clean flux for RoHS compliant products.
- During the pick and place process, axial forces on the dome (or window) should not exceed 0.5 Newtons (N).
- Use of a multi-zone IR reflow oven with a nitrogen blanket is recommended.
- Time-temperature profile of the reflow process showing the four functional profile zones are defined in IPC-7801. Temperature is referenced to the center of the PCB.
- Luminus recommends using the solder paste data sheet information as a starting point in time-temperature process development.
- These are general guidelines. Consult the solder paste manufacturer's datasheet for guidelines specific to the alloy and flux combination used in your application. For more information, please refer to: <https://luminusdevices.zendesk.com/hc/en-us/articles/360060306692-How-do-I-Reflow-Solder-Luminus-SMD-Components->
- For any technical questions about soldering process, please contact Luminus at techsupport@luminus.com.



Tape and Reel Outline

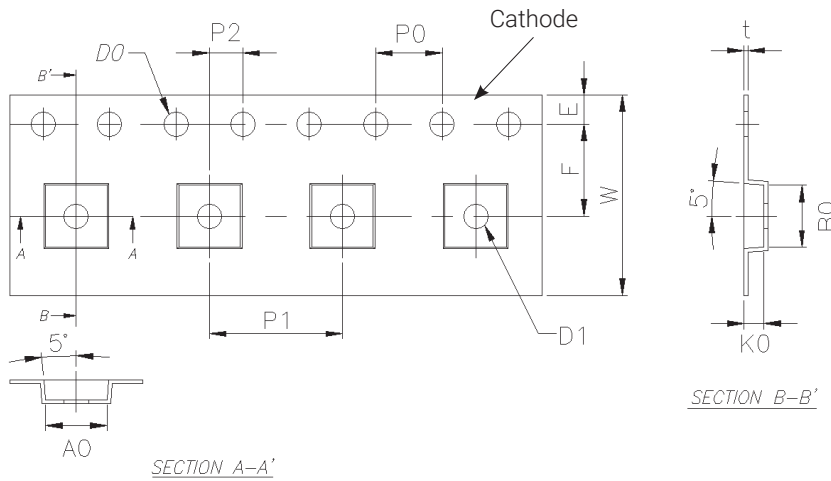

Parameter	Dimension (mm)
A0	3.70±0.10
B0	3.70±0.10
D0	1.50+0.10, -0
D1	1.50±0.10
E	1.75±0.10
F	5.50±0.10
K0	1.20±0.10
P0	4.00±0.10
P1	8.00±0.10
P2	2.00±0.10
t	0.23±0.05
W	12±0.3

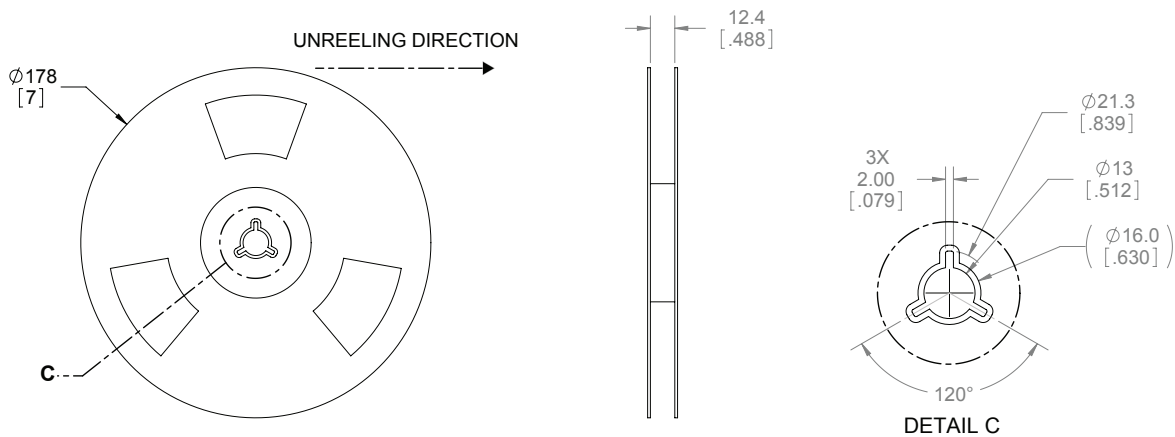

Notes:

1. Each Reel contains 500 units of LEDs.
2. Black ant-static tape material (Denka ECMB/ECAP3).
3. The accumulated tolerance for ten chain holes should be no more than 0.2 mm.
4. The tortuosity of 250 mm tape should be no more than 1 mm.
5. Leave minimum 800 mm with empty compartments sealed by cover tape for lead in.
6. Leave minimum 1200 mm with empty compartments sealed by cover tape for trailer.
7. All dimensions must comply to EIA-481-D
8. Final tape and reel packaging must meet the requirements of JEDEC-STD-033, LEVEL 2A.



Shipping Label

Label on Packaging Box

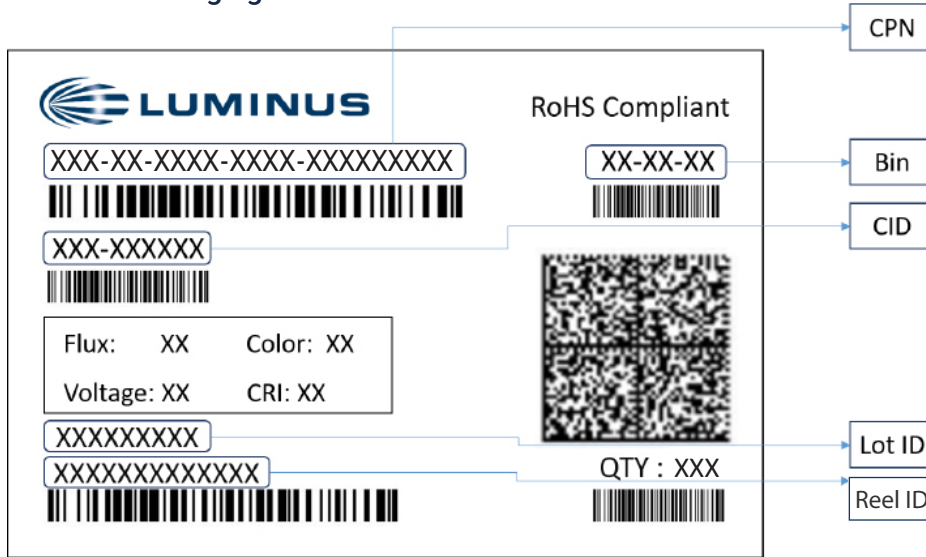

Label Fields:

- CPN:** Luminus ordering part number
- CID:** Customer's part number
- QTY:** Quantity of parts per reel
- Flux:** Bin as defined on page 3
- Voltage:** Bin as defined on page 3
- Color:** Bin as defined on page 4 - 6
- CRI:** NA
- Lot ID & Reel ID:** For Luminus internal use

Label on Reel

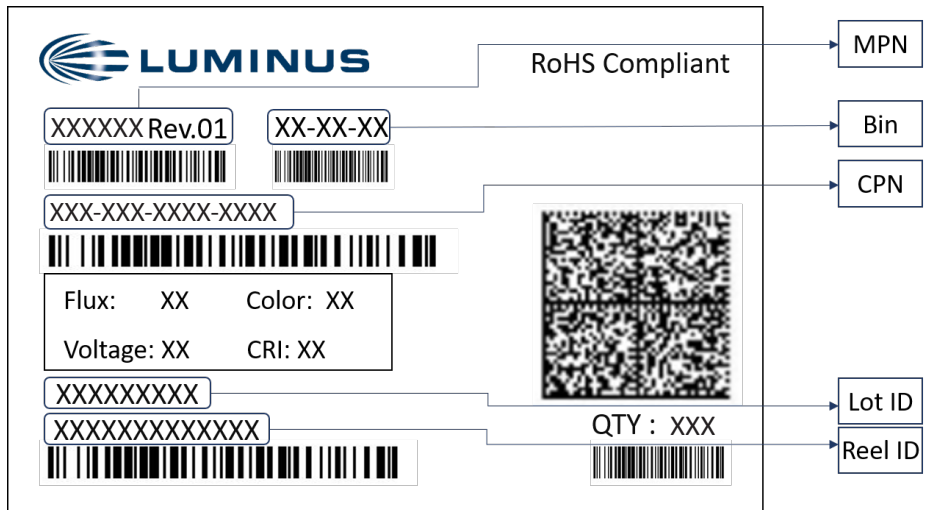

Label Fields:

- CPN:** Luminus ordering part number
- MPN:** For Luminus internal use
- QTY:** Quantity of parts per reel
- Flux:** Bin as defined on page 3
- Voltage:** Bin as defined on page 3
- Color:** Bin as defined on page 4 - 6
- CRI:** NA
- Lot ID & Reel ID:** For Luminus internal use



Packaging

Packaged Reel

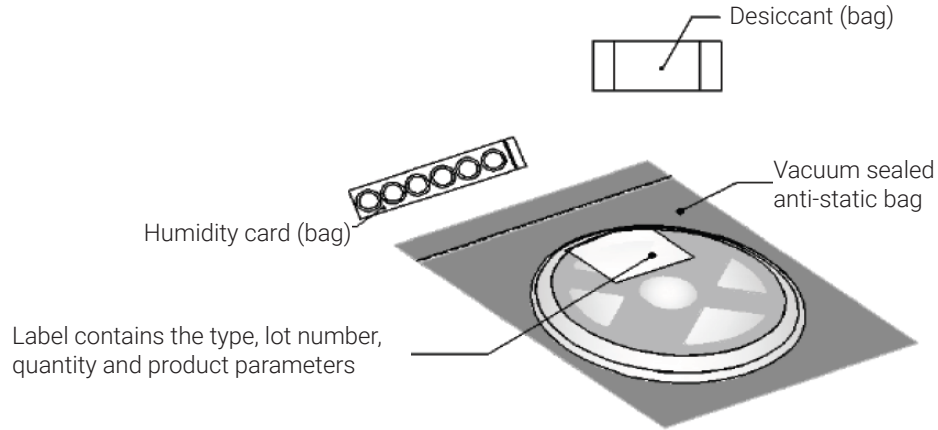

Packaging boxes

Box Size 1 - 5 reels per box
Size: 22.5 x 24.5 x 6.5 cm

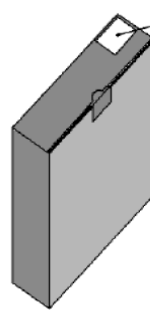
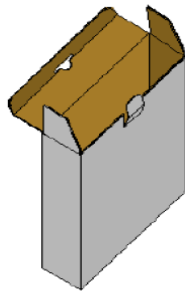

Label contains the type, lot number, quantity and product parameters

Box Size 2 - 10 reels per box
Size: 22.5 x 24.5 x 13 cm

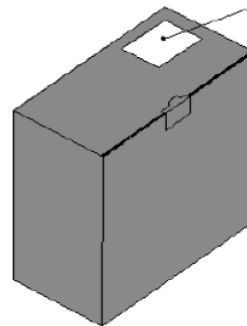
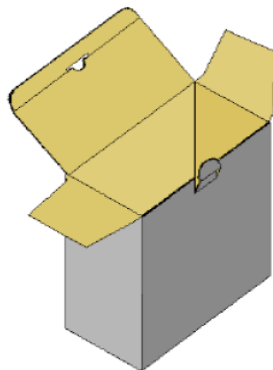

Label contains the type, lot number, quantity and product parameters

Packing Configuration:

- 500 units per reel
- Each reel is enclosed in anti-static bag
- Shipping label is placed on top of each reel
- Multiple labels are attached to the box (one label per reel inside the box)



Notes

Environmental Compliance

Luminus complies with RoHS and REACH. Luminus is committed to selling environmentally friendly and sustainable products. We do not use harmful or hazardous substances in our composites and products. Luminus will not intentionally add the following restricted materials to our products: lead, mercury, cadmium, hexavalent chromium, polybrominated biphenyls (PBB), or polybrominated diphenyl ethers (PBDE).

Static Electricity

1. The products are sensitive to static electricity, and care should be taken when handling them.
2. Static electricity or surge voltage will damage the LEDs. It is recommended to wear anti-electrostatic gloves or a wristband when handling the LEDs.
3. All devices, equipment and machinery must be properly grounded. It is recommended that measures be taken against surge voltage to the equipment that mounts the LEDs.

Reference: [APN-002815](#) Electrical Stress Damage to LEDs and How to Prevent It

Storage

Please follow J-STD-033D guidance on safe storage and bake treatment.

1. Before opening the package

The LEDs should be kept at a temperature lower than 40°C and relative humidity lower than 90%. The LEDs should be used within a year. When storing the LEDs, moisture proof package with absorbent material (silica gel) is recommended.

2. After opening the package

The LEDs should be kept at a temperature lower than 30°C and relative humidity lower than 60%. The LEDs should be soldered within 168 hours (7 days) after opening the moisture proof package.

If unused LEDs remain, they should be stored in moisture proof packages, such as sealed containers with moisture absorbent material (silica gel). It is also recommended to return the unused LEDs to the original moisture proof package and to seal it again.

If the moisture absorbent material (silica gel) vaporizes or passes the expiration date, baking treatment should be performed by using the following conditions : 60°C for 20 hours.

The LED's electrode and lead frame comprise a silver plated copper alloy. The silver surface may be affected by environments. Please avoid conditions which may cause the LEDs to corrode or discolor. The corrosion or discoloration might lower solderability or affect optical characteristics.

Please avoid rapid transition in ambient temperature, especially in high humidity environments where condensation can occur.