

SFT-14-B

SFT-14-BP

Projection LED

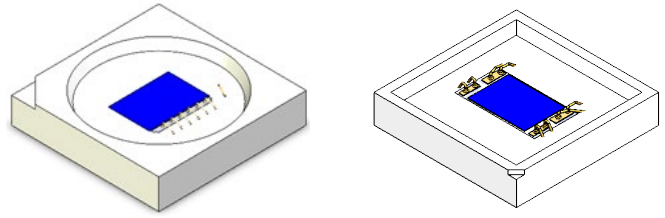

Features

- 1.4 mm² emitting area
- Complement to SFT-14 Red Amber (RA) and Converted Green (CG) for best projection brightness and color gamut
- Matched to 0.2" / 0.3" Pico projection applications
- Drive current up to 9.1 A
- Standard 3535 SMT packages
- Low thermal resistance: 1.6°C/W
- Dominant wavelength: Blue 459 nm, Blue Pump 448 nm.
- Flat surface emission for high collection efficiency



Applications

- Suitable for micro-display sizes 0.3x" and 0.2x"
- Medical / Life Science
- Industrial
- Transportation / Beacons
- High performance illumination
- Specifically engineered for stand alone, embedded, or battery-assisted projection display applications

Table of Contents

Ordering Information.	2
Binning Structure.	3
Characteristics	4
Angular Distribution and Typical Spectrum	9
Absolute Maximum Ratings.	11
Mechanical Dimensions.	12
Mechanical Characteristics.	14
Soldering Profile.	15
Tape and Reel Outline	16
Shipping Label	17
Packaging	18
Notes	19
Revision History.	20



Ordering Information

Ordering Part Numbers¹

Color	Radiometric Flux		Wavelength Bin ²	Ordering Part Number
	Minimum Flux Bin	Minimum Flux		
Blue	4E	1.30 W	B2, B6, B7	SFT-14-B-F35-EPE650
	4F	1.45 W	B2, B6, B7	SFT-14-B-F35-EPF650
Blue Pump	4F	1.45 W	B0, B1	SFT-14-BP-F35-EPF650
	4G	1.60 W	B0, B1	SFT-14-BP-F35-EPG650

Part Number Nomenclature

SFT

14

##

F35

<Bin kit>

Product Family	Chip Area	Color	Package Configuration	Bin Kit
SFT: Surface-Mount Flat-Top	14: 1.4 mm ²	B: Blue BP: Blue Pump	F35: 3535 EMC SMD See Mechanical Drawing section	Refer to ordering part numbers in this document

Notes:

1. Flux Bin listed is minimum bin shipped, higher bins may be included at Luminus' discretion.
2. B2 bin will be phased out once existing stock is depleted.



Binning Structure

Luminous Flux Bins^{1,2}

Flux Bin ³	Binning @ 0.98 A, T _c = 25°C ⁴	
	Minimum Flux (W)	Maximum Flux (W)
4E	1.30	1.45
4F	1.45	1.60
4G	1.60	1.75
4H	1.75	1.90

Dominant Wavelength Bins^{2,5}

Color	Wavelength Bin ³	Binning @ 0.98 A, T _c = 25°C ⁴	
		Minimum Wavelength (nm)	Maximum Wavelength (nm)
Blue Pump	B0	441	449
	B1	449	455
Blue	B2 (under EOL)	455	465
	B6	454	462
	B7	462	465

Notes:

1. Luminus maintains a +/- 6% tolerance on flux measurements.
2. Products are production tested then sorted and packed by bin.
3. Individual bins are not orderable.
4. T_c = Case temperature.
5. B2 bin will be phased out once existing stock is depleted.



Characteristics

Parameter ($I_f = 0.98 \text{ A}$, $T_c = 25^\circ\text{C}$)		Symbol	Blue	Blue Pump	Unit
Light Emitting Area		A_E	1.40	1.40	mm ²
Peak Luminous Flux ¹		Φ_V	45	40	lm
Peak Radiometric Flux ¹		Φ_E	1.50	1.75	W
Forward Voltage	Minimum	$V_{f \text{ min}}$	2.5	2.5	V
	Typical	$V_{f \text{ typ}}$	3.0	3.0	
	Maximum	$V_{f \text{ max}}$	3.6	3.6	
Dominant Wavelength	Minimum	$\lambda_{d \text{ min}}$	455	441	nm
	Typical	$\lambda_{d \text{ typ}}$	459	448	
	Maximum	$\lambda_{d \text{ max}}$	465	455	
FWHM		$\Delta\lambda_{1/2}$	19	19	nm
Chromaticity Coordinates (Full spectrum) ²		CIE x	0.15	0.15	
		CIE y	0.04	0.04	
Real Thermal Resistance (Junction to Case) ³		$R_{th \text{ JC real}}$	1.60		°C/W
Electrical Thermal Resistance (Junction to Case) ^{3,4}		$R_{th \text{ JC elec}}$	0.72		°C/W

Notes:

1. Typical flux at typical dominant wavelength.
2. CIE 1931 chromaticity diagram coordinates, normalized to X+Y+Z=1.
3. Thermal measurements are in accordance with JEDEC 51-14.
4. For optimal results, Luminus recommends customer PCB Design per guidelines from Luminus application note, "Design Guidelines for SFT Chipset Assembly".



Characteristics (Standard Test Condition)

Relative Luminous Flux - Blue

Forward Current: $\phi_v/\phi_v(0.98\text{ A})$ Single pulse 20 ms, $T_c = 25^\circ\text{C}$

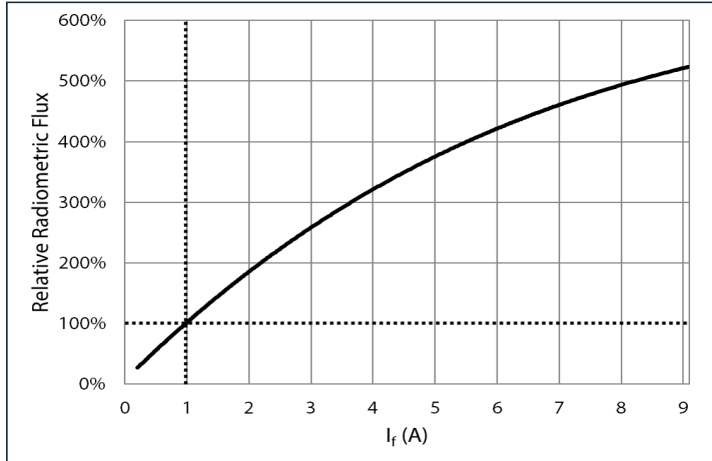

Temperature: $\phi_v/\phi_v(25^\circ\text{C})$ Single pulse 20 ms, $I_f = 0.98\text{ A}$

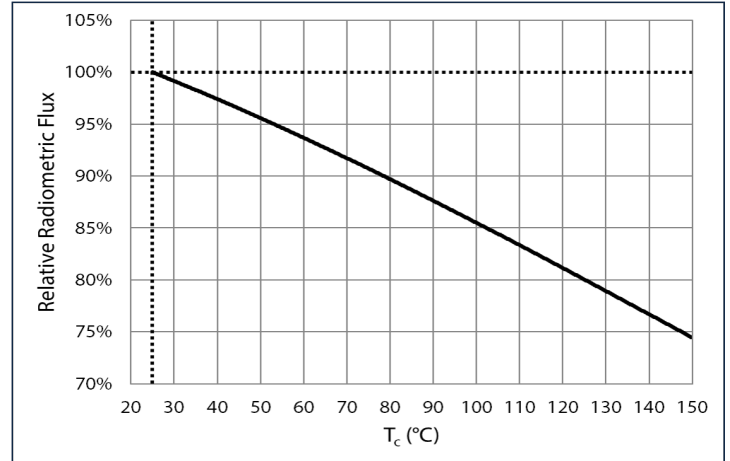

Forward Voltage - Blue

Forward Current: $\Delta V_f = V_f(I_f) - V_f(0.98\text{ A})$ Single pulse 20 ms, $T_c = 25^\circ\text{C}$

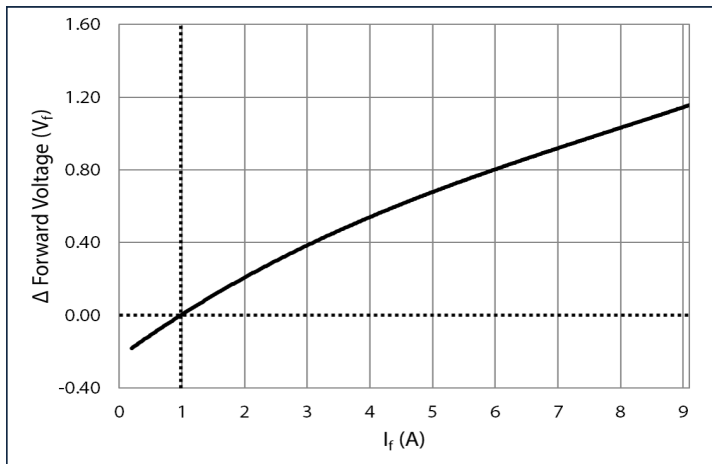

Temperature: $\Delta V_f = V_f(T_c) - V_f(25^\circ\text{C})$ Single pulse 20 ms, $I_f = 0.98\text{ A}$

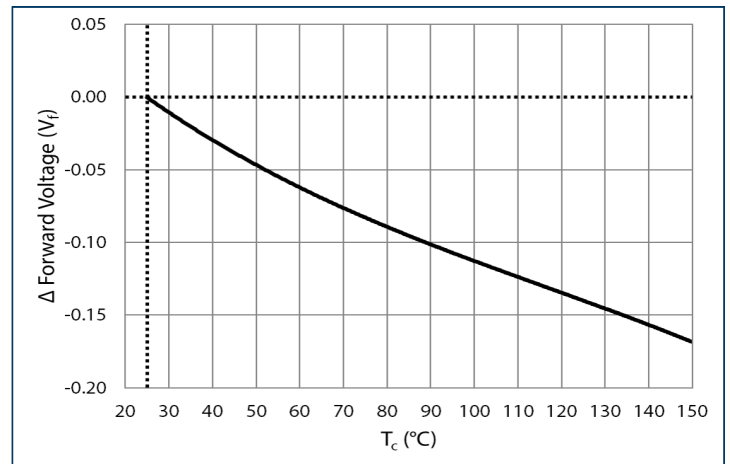

Dominant Wavelength Shift- Blue

Forward Current: $\Delta \lambda_d = \lambda_d(I_f) - \lambda_d(0.98\text{ A})$ Single pulse 20 ms, $T_c = 25^\circ\text{C}$

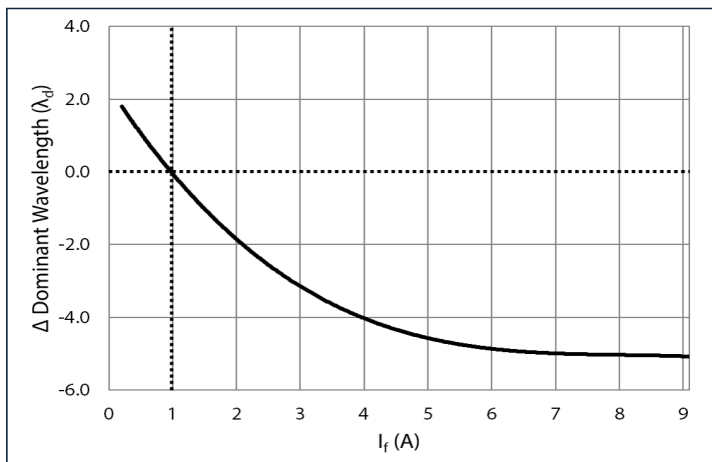

Temperature: $\Delta \lambda_d = \lambda_d(T_c) - \lambda_d(25^\circ\text{C})$ Single pulse 20 ms, $I_f = 0.98\text{ A}$

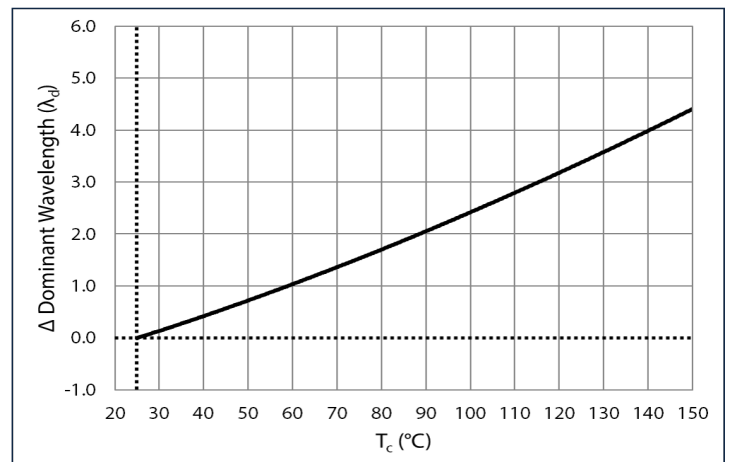



Characteristics (Standard Test Condition)

Relative Luminous Flux - Blue Pump

Forward Current: $\phi_v/\phi_v(0.98\text{ A})$ Single pulse 20 ms, $T_c = 25^\circ\text{C}$

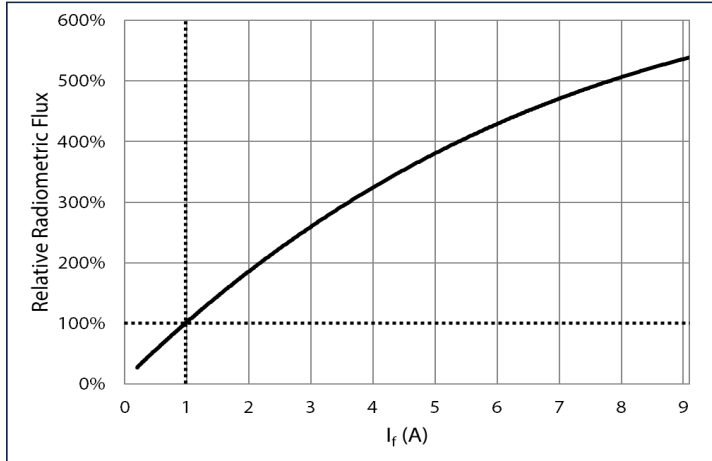

Temperature: $\phi_v/\phi_v(25^\circ\text{C})$ Single pulse 20 ms, $I_f = 0.98\text{ A}$

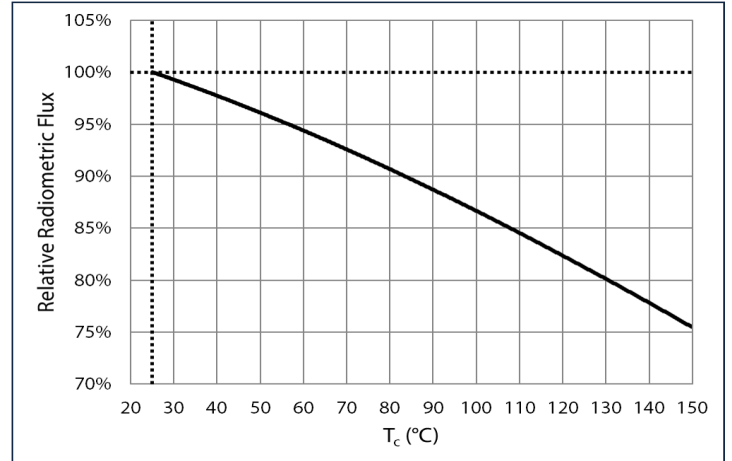

Forward Voltage - Blue Pump

Forward Current: $\Delta V_f = V_f(I_f) - V_f(0.98\text{ A})$ Single pulse 20 ms, $T_c = 25^\circ\text{C}$

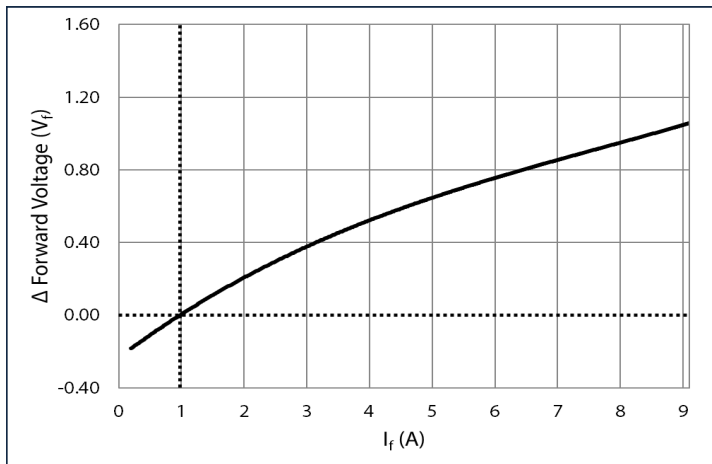

Temperature: $\Delta V_f = V_f(T_c) - V_f(25^\circ\text{C})$ Single pulse 20 ms, $I_f = 0.98\text{ A}$

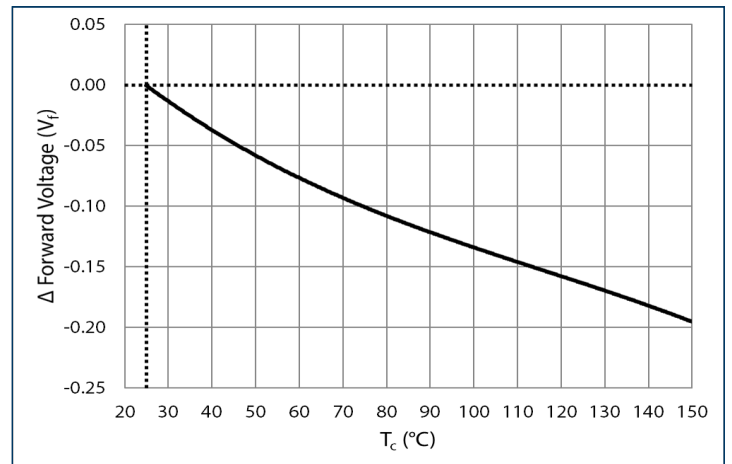

Dominant Wavelength Shift- Blue Pump

Forward Current: $\Delta \lambda_d = \lambda_d(I_f) - \lambda_d(0.98\text{ A})$ Single pulse 20 ms, $T_c = 25^\circ\text{C}$

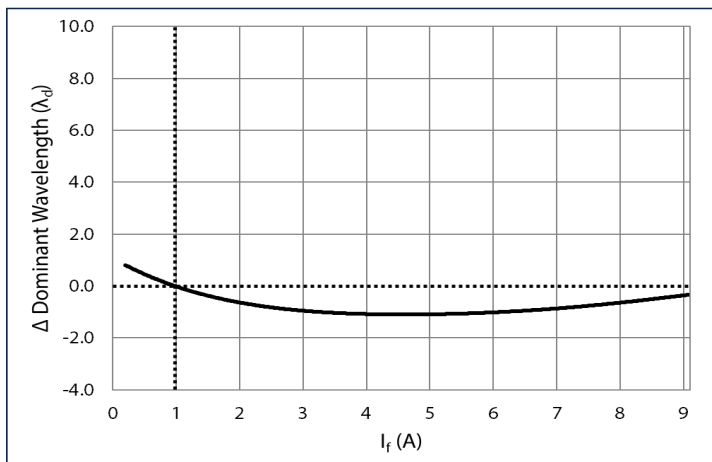

Temperature: $\Delta \lambda_d = \lambda_d(T_c) - \lambda_d(25^\circ\text{C})$ Single pulse 20 ms, $I_f = 0.98\text{ A}$

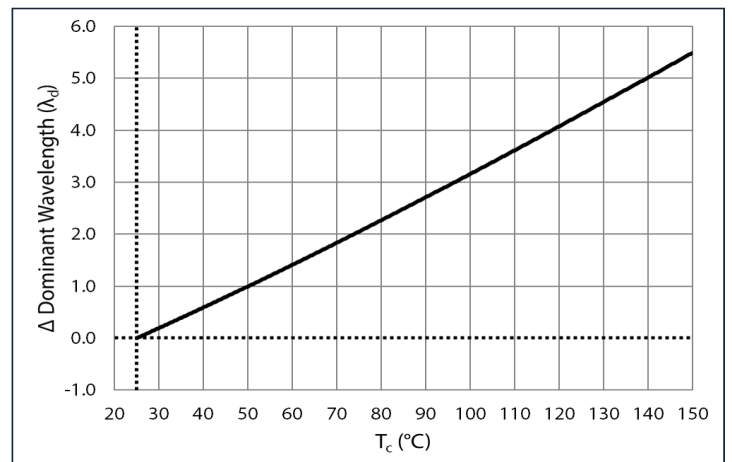



Characteristics (Reference test condition)

Relative Luminous Flux - Blue

Forward Current: $\phi_v/\phi_v(0.98\text{ A})$ Single pulse 1 ms, $T_c = 25^\circ\text{C}$

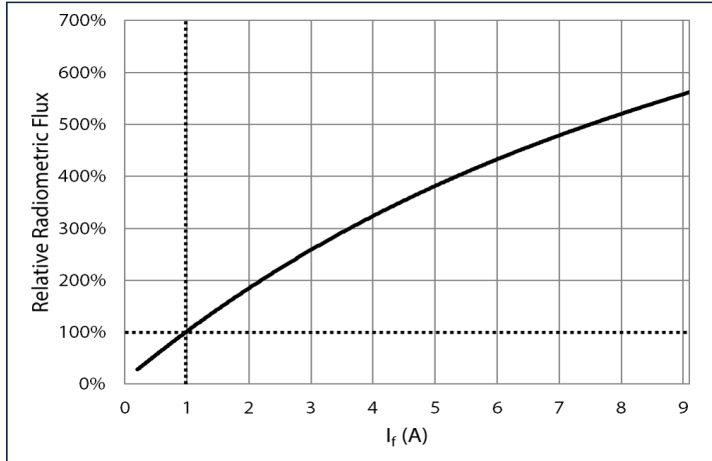

Temperature: $\phi_v/\phi_v(25^\circ\text{C})$ Single pulse 1 ms, $I_f = 0.98\text{ A}$

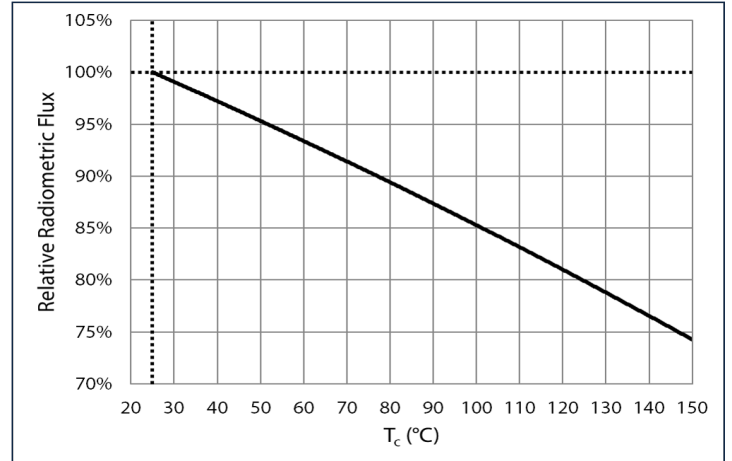

Forward Voltage - Blue

Forward Current: $\Delta V_f = V_f(I_f) - V_f(0.98\text{ A})$ Single pulse 1 ms, $T_c = 25^\circ\text{C}$

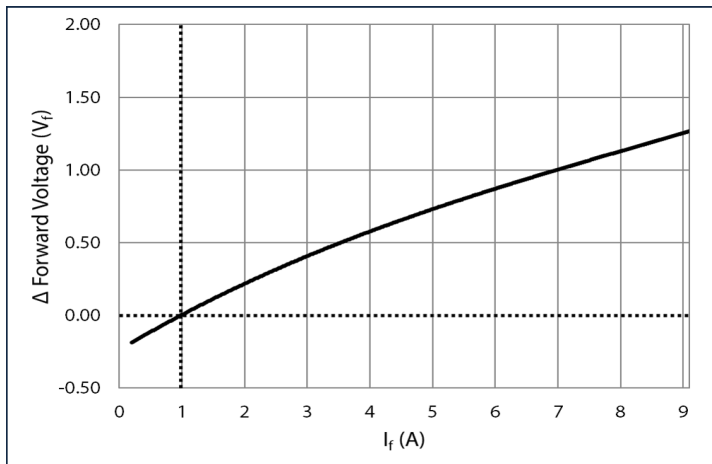

Temperature: $\Delta V_f = V_f(T_c) - V_f(25^\circ\text{C})$ Single pulse 1 ms, $I_f = 0.98\text{ A}$

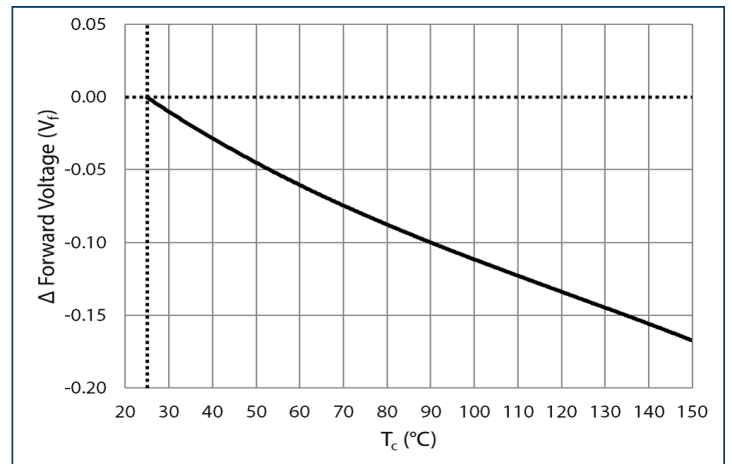

Dominant Wavelength Shift- Blue

Forward Current: $\Delta \lambda_d = \lambda_d(I_f) - \lambda_d(0.98\text{ A})$ Single pulse 1 ms, $T_c = 25^\circ\text{C}$

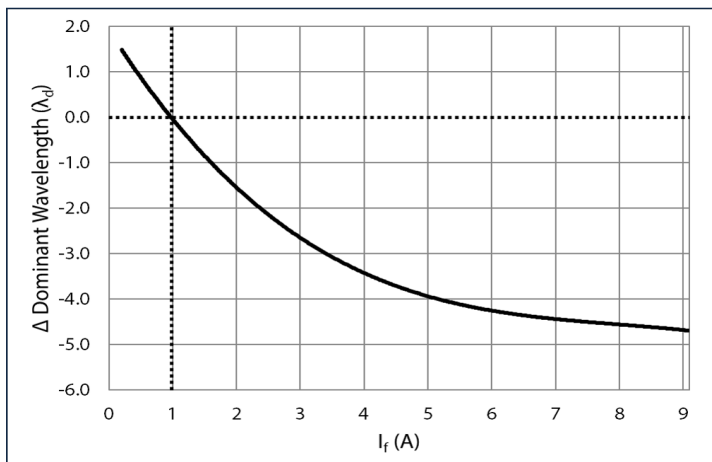

Temperature: $\Delta \lambda_d = \lambda_d(T_c) - \lambda_d(25^\circ\text{C})$ Single pulse 1 ms, $I_f = 0.98\text{ A}$

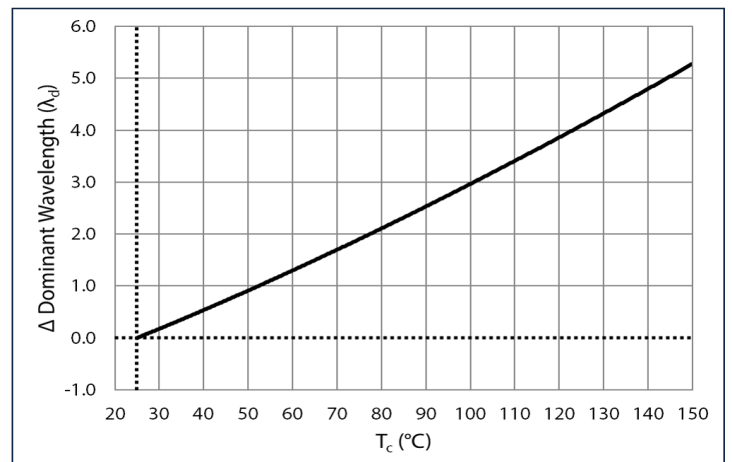



Characteristics (Reference test condition)

Relative Luminous Flux - Blue Pump

Forward Current: $\phi_v/\phi_v(0.98\text{ A})$ Single pulse 1 ms, $T_c = 25^\circ\text{C}$

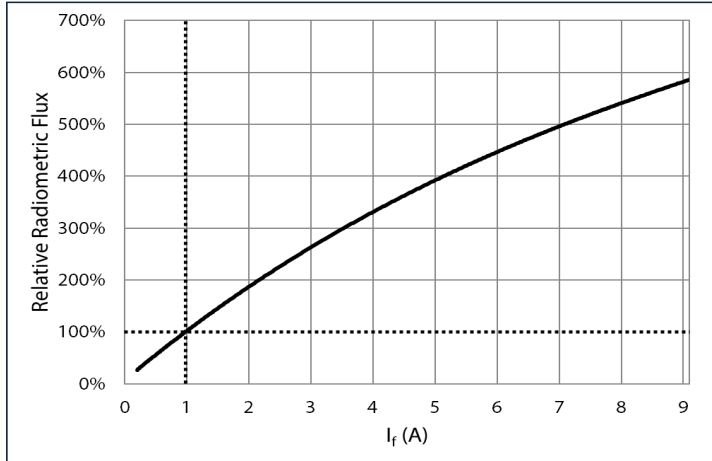

Temperature: $\phi_v/\phi_v(25^\circ\text{C})$ Single pulse 1 ms, $I_f = 0.98\text{ A}$

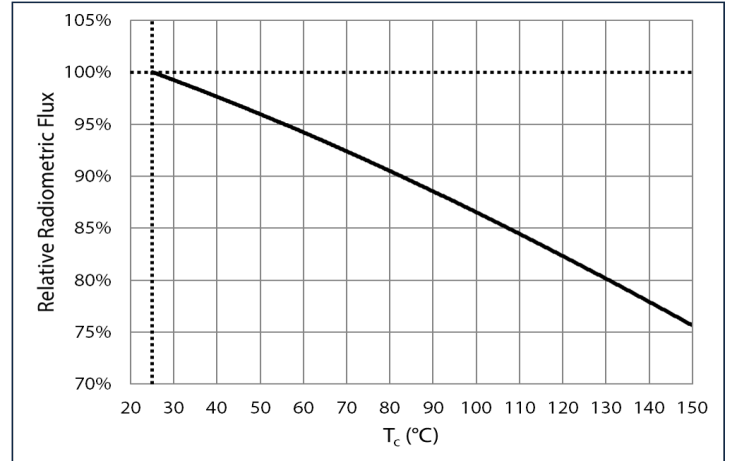

Forward Voltage - Blue Pump

Forward Current: $\Delta V_f = V_f(I_f) - V_f(0.98\text{ A})$ Single pulse 1 ms, $T_c = 25^\circ\text{C}$

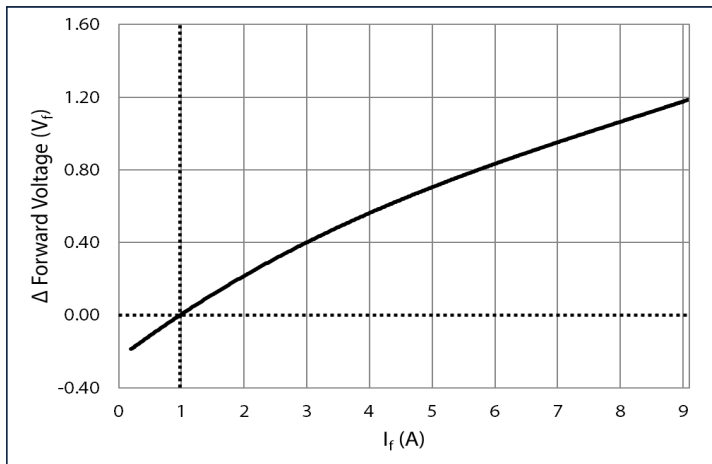

Temperature: $\Delta V_f = V_f(T_c) - V_f(25^\circ\text{C})$ Single pulse 1 ms, $I_f = 0.98\text{ A}$

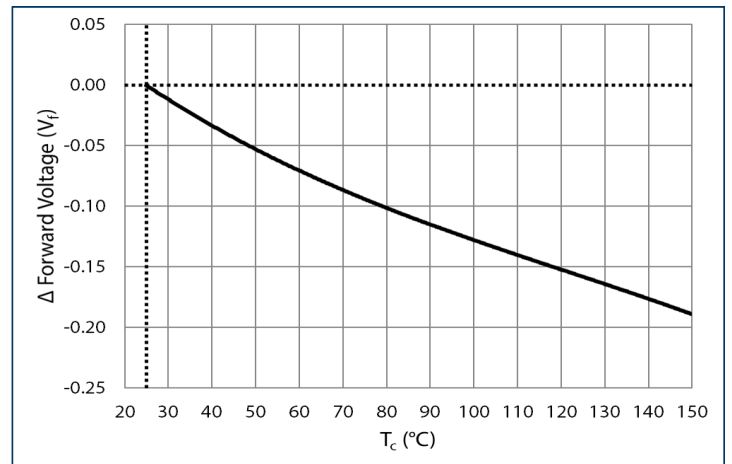

Dominant Wavelength Shift- Blue Pump

Forward Current: $\Delta \lambda_d = \lambda_d(I_f) - \lambda_d(0.98\text{ A})$ Single pulse 1 ms, $T_c = 25^\circ\text{C}$

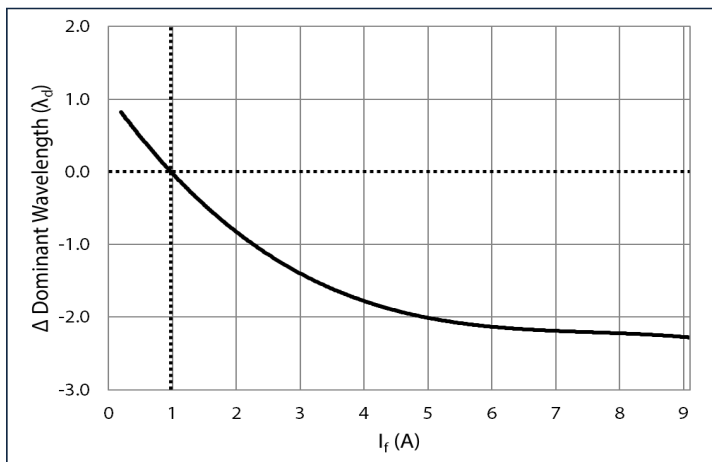

Temperature: $\Delta \lambda_d = \lambda_d(T_c) - \lambda_d(25^\circ\text{C})$ Single pulse 1 ms, $I_f = 0.98\text{ A}$

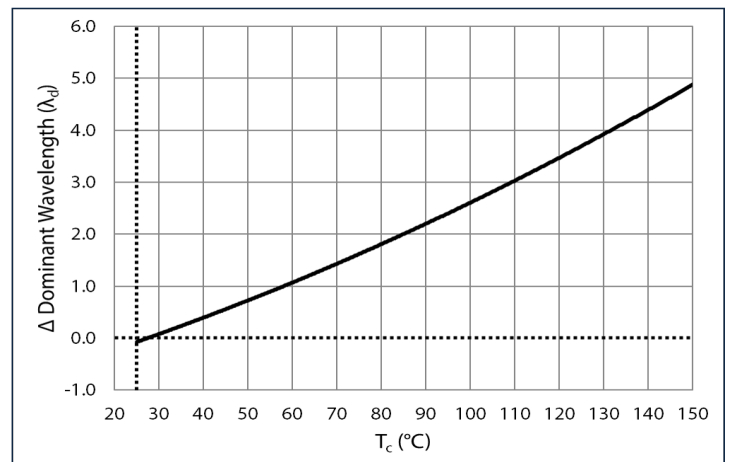



Angular Distribution and Typical Spectrum

Angular Distribution - Blue

$I_f = 0.98 \text{ A}; T_c = 25^\circ\text{C}$

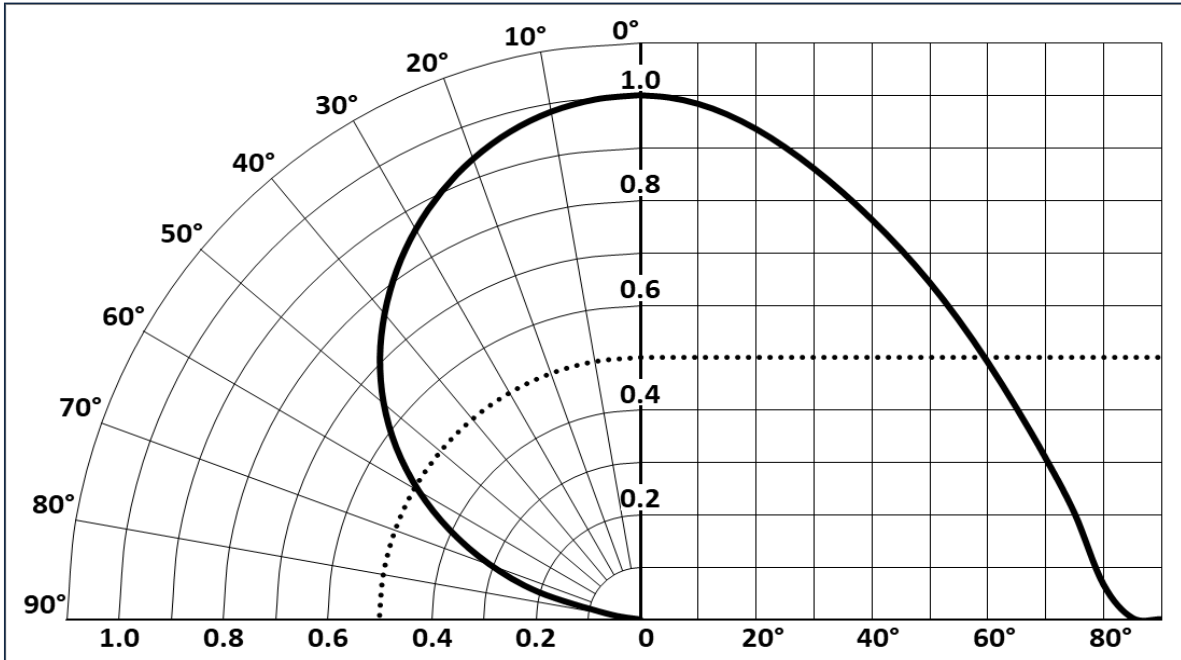

Angular Distribution - Blue Pump

$I_f = 0.98 \text{ A}; T_c = 25^\circ\text{C}$

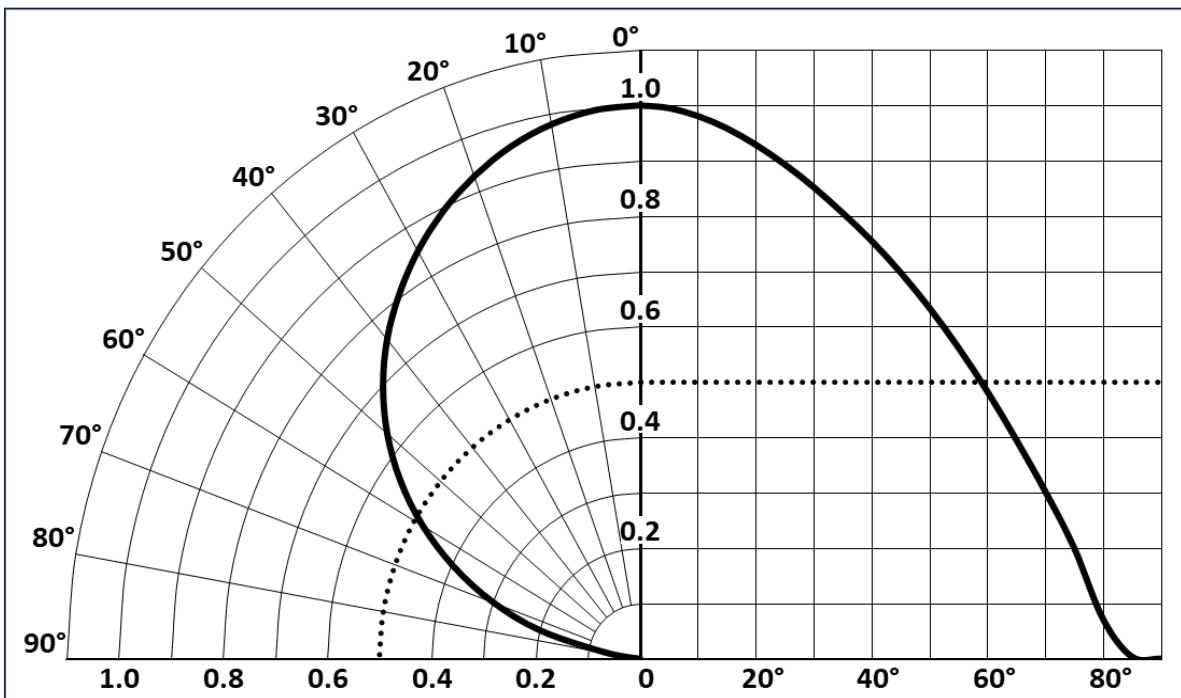



Angular Distribution and Typical Spectrum

Relative Spectral Power Distribution - Blue

$I_f = 0.98 \text{ A}$; $T_c = 25^\circ\text{C}$

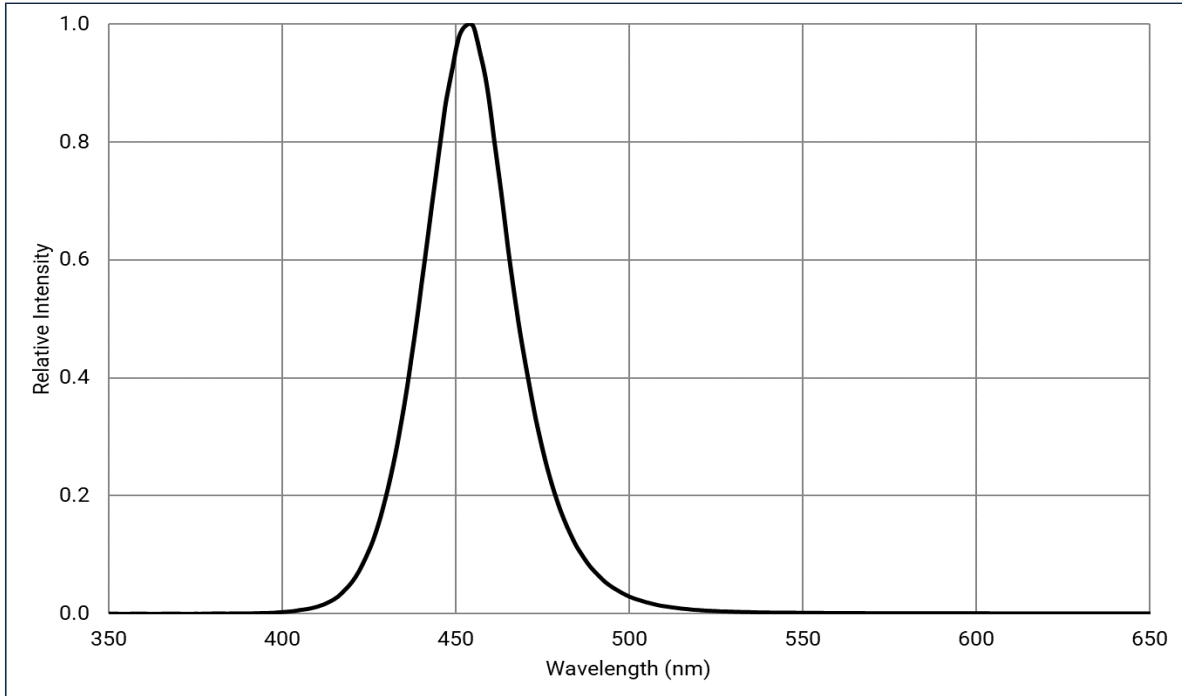

Relative Spectral Power Distribution - Blue Pump

$I_f = 0.98 \text{ A}$; $T_c = 25^\circ\text{C}$

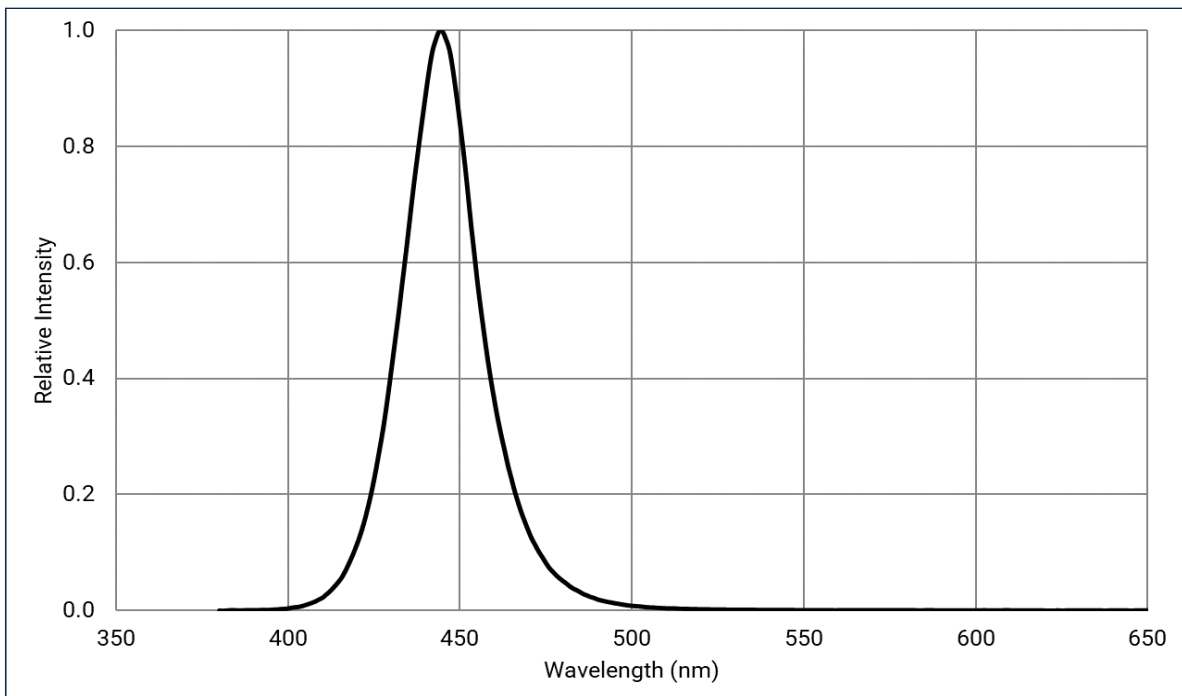



Absolute Maximum Ratings¹

Parameter		Symbol	Values	Unit
Forward Current (Pulsed) ² (Frequency > 240 Hz, Duty < 70%)	Minimum	$I_{f \text{ pulse min}}$	0.2	A
	Maximum	$I_{f \text{ pulse max}}$	9.1	
Forward Current (CW) ^{3,4}	Minimum	$I_{f \text{ CW min}}$	0.2	
	Maximum	$I_{f \text{ CW max}}$	7.7	
Forward Surge Current (Pulsed) ^{2,3,4} Frequency > 240 Hz, duty cycle < 10% or t = 1 ms		I_s	9.8	A
Junction Temperature		T_j	150	°C
Storage Temperature Range		T_{stg}	-40 to 100	°C
ESD withstand Voltage ANSI/ESDA/JEDEC JS-001 (HBM, Class 2)		V_{ESD}	2	kV

Notes:

1. All ratings are based on standard testing conditions at drive current 0.98 A, 20 ms single pulse at $T_c = 25^\circ\text{C}$.
2. In pulsed operation, rise time from 10% to 90% of forward current should be larger than 0.5 microseconds.
3. Product performance and lifetime data is specified at recommended forward drive current. Sustained operation at or near absolute minimum current may result in a reduction of device performance and device lifetime compared to recommended forward drive current.
4. Sustained operation above maximum current is not recommended and will result in a reduction of device lifetime.



Mechanical Dimensions - Square cavity

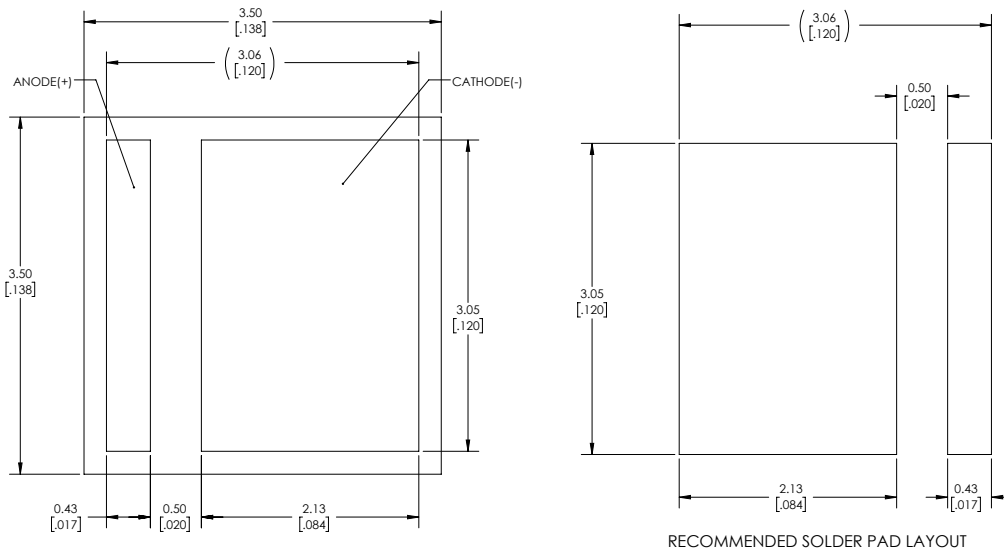
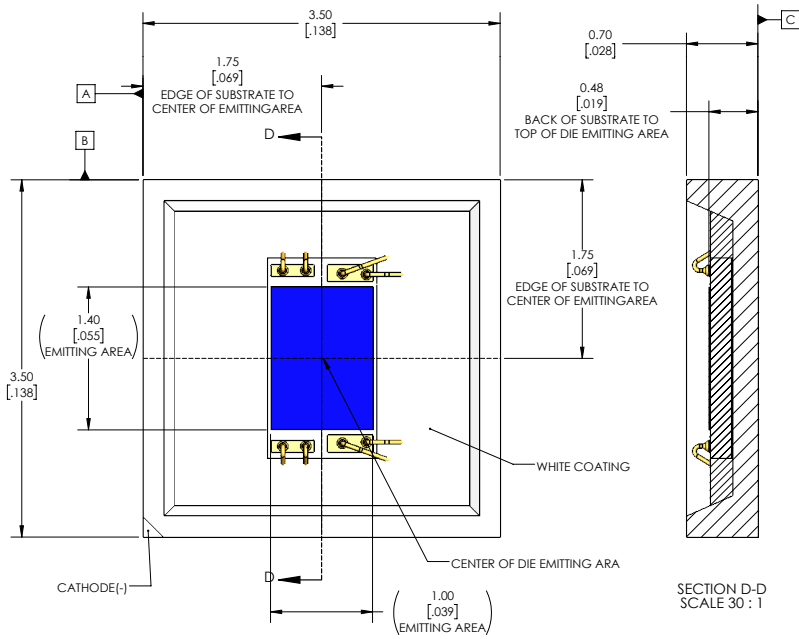



Mechanical Characteristics

JEDEC Moisture Sensitivity¹

Level	Floor Life	
	Time	Conditions
3	168 Hours	≤30°C / 60% RH

Notes:

1. Please note that the above MSL level based on the MSL qualification rating.



Soldering Profile

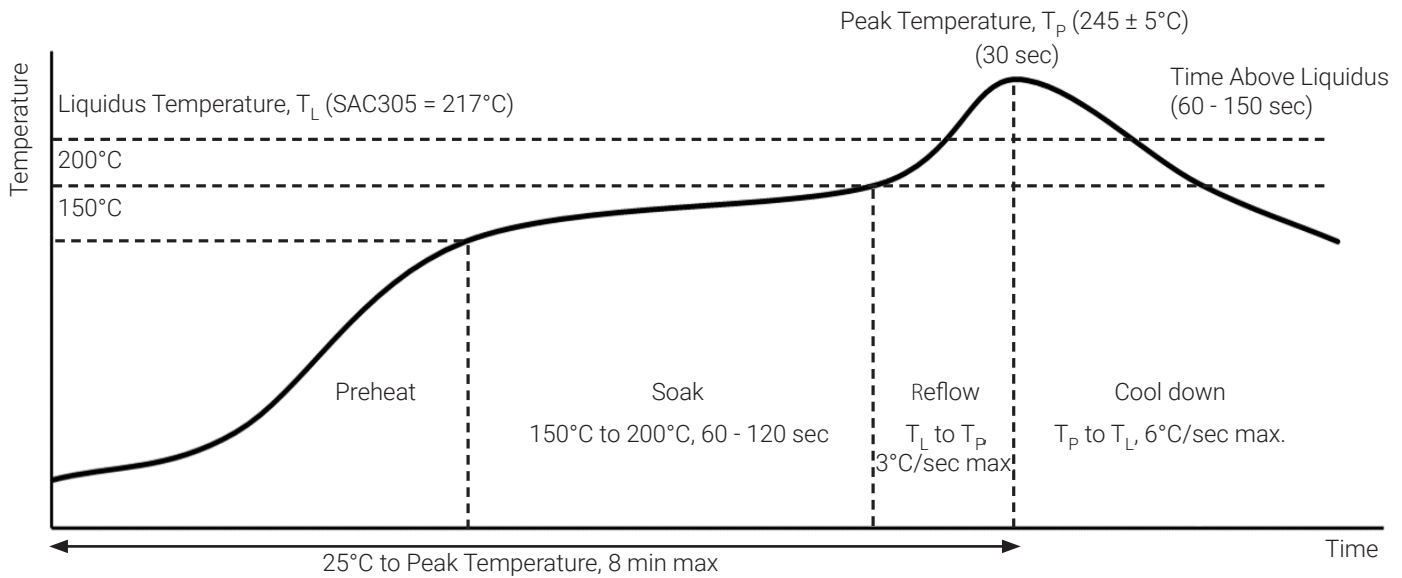

SMT Solder Rework Temperature Guidelines

Parameter	Manual Hotplate Reflow	Hot Air Gun Reflow
Heating Time	< 60 sec	
Hotplate Temperature	< 245°C	< 150°C

Notes:

- The numbers in the table are specific to SAC305. Luminus recommends using an SAC305 solder paste with a no-clean flux for RoHS compliant products.
- Use of a multi-zone IR reflow oven with a nitrogen blanket is recommended.
- Time-temperature profile of the reflow process showing the four functional profile zones are defined in IPC-7801. All the temperatures refer to the application PCB measured adjacent to the package body.
- The actual profile shall be optimized per the PCB design and configuration.
- Key visual and LED performance characteristics to consider include solder bridging, solder voiding, solder balling, LED component placement or shifting, potential contamination that may impact light emissions, and the functional performance of the LED.
- Luminus recommends to use the solder paste data sheet information as a starting point in time-temperature process development.
- These are general guidelines. Consult the solder paste manufacturer's datasheet for guidelines specific to the alloy and flux combination used in your application. For more information, please refer to: <https://luminusdevices.zendesk.com/hc/en-us/articles/360060306692-How-do-I-Reflow-Solder-Luminus-SMD-Components->
- For any technical questions about soldering process, please contact Luminus at techsupport@luminus.com.



Tape and Reel Outline

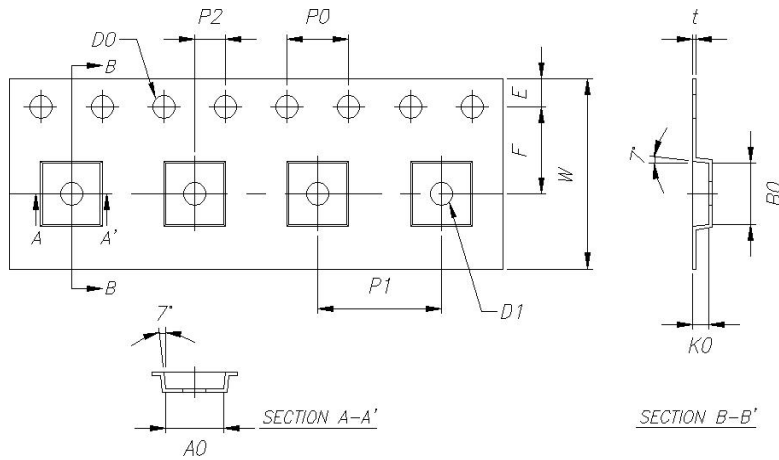

Parameter	Dimension (mm)
B0	4.00 ± 0.10
K0	1.20 ± 0.10
P0	4.00 ± 0.10
P1	8.00 ± 0.10
P2	2.00 ± 0.05
T	0.30 ± 0.05
E1	1.75 ± 0.10
F	5.50 ± 0.05
D0	1.55 ± 0.05
D1	1.55 ± 0.05
W	12.00 ± 0.10

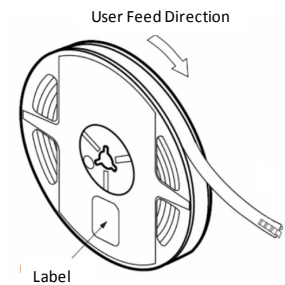
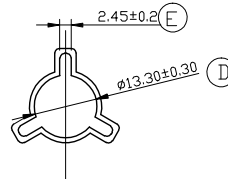
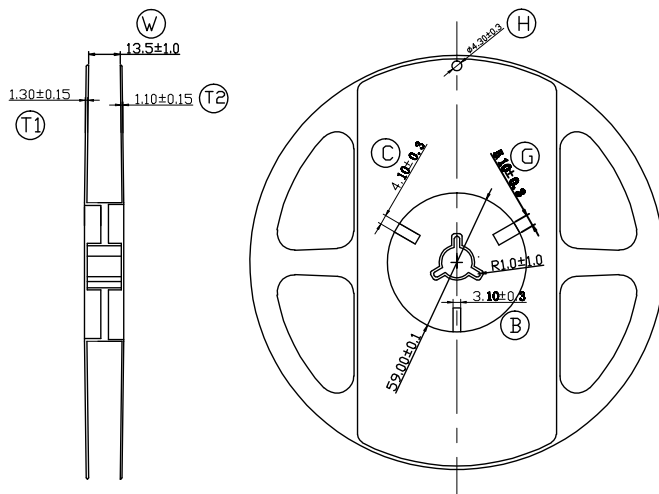

Parameter	Quantity (pcs)
Pieces per reel	250
	500

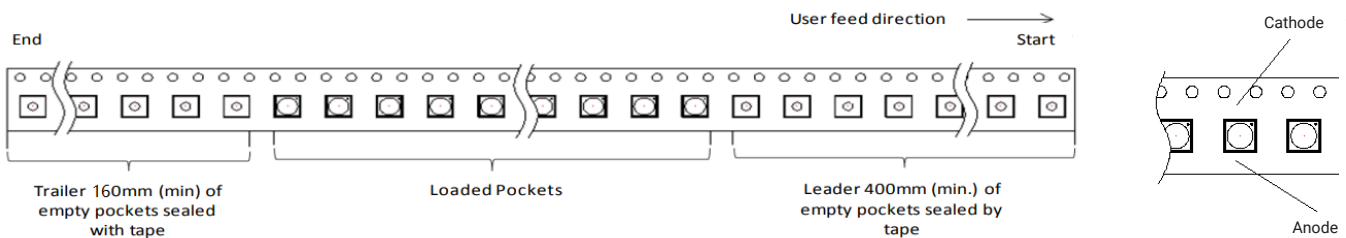

Notes:

1. The quantity per reel is not orderable.
2. Minimum order quantity: 500 pcs.



Shipping Label

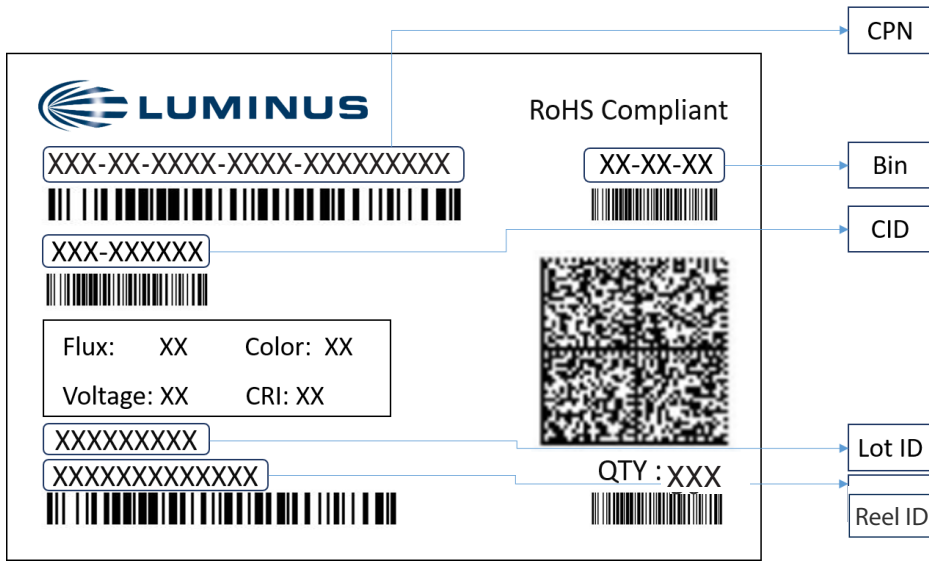

Label Fields:

- CPN: Luminus ordering part number
- CID: Customer's part number
- QTY: Quantity of parts per reel
- Flux: Bin as defined on page 3
- Voltage: N/A
- Color: Bin as defined on page 3
- CRI: N/A
- Lot ID & Reel ID: For Luminus internal use

Packing Configuration:

- Maximum of 500 devices per reel
- Each reel is enclosed in anti-static bag
- Shipping label is placed on top of each reel
- Partial reel may be shipped



Packaging

Packaged Reel

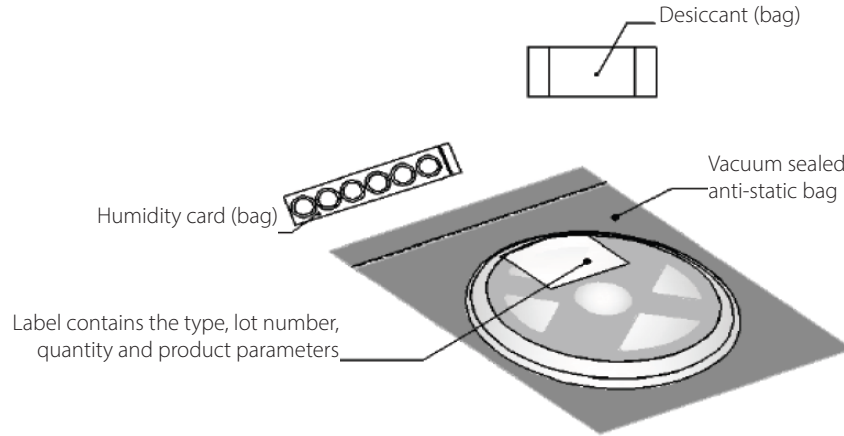

Packaging boxes

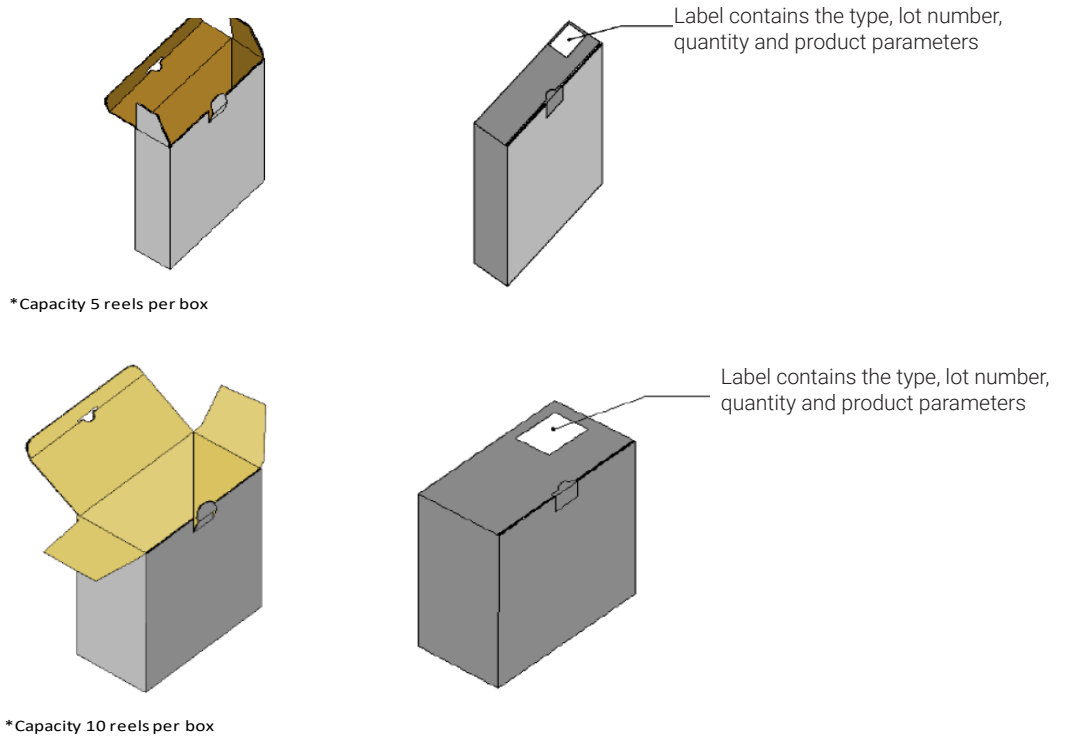



Notes

Environmental Compliance

Luminus complies with RoHS and REACH. Luminus is committed to selling environmentally friendly and sustainable products. We do not use harmful or hazardous substances in our composites and products. Luminus will not intentionally add the following restricted materials to our products: lead, mercury, cadmium, hexavalent chromium, polybrominated biphenyls (PBB), or polybrominated diphenyl ethers (PBDE).

Static Electricity

1. The products are sensitive to static electricity, and care should be taken when handling them.
2. Static electricity or surge voltage will damage the LEDs. It is recommended to wear anti-electrostatic gloves or wristband when handling the LEDs.
3. All devices, equipment and machinery must be properly grounded. It is recommended that measures be taken against surge voltage to the equipment that mounts the LEDs.

Reference: [APN-002815](#) Electrical Stress Damage to LEDs and How to Prevent It

Storage

Please follow J-STD-033D guidance on safe storage and bake treatment.

Mechanical Handling

1. xFx series: During the pick and place process, ensure the pick-up tool does not touch any die components.
2. xBx and xSx series: During the pick and place process, axial forces on the dome (or window) should not exceed 0.5 Newtons (N).
3. PT series: During the pick and place process, ensure the pick-up tool does not touch any die components. This profile applies when attaching surface mount components.
4. SBT series: During the pick and place process, axial forces on the dome (or window) should not exceed 0.5 Newtons (N). Vapor phase soldering is not recommended as the package is not hermetic.

Eye Safety

According to the test specification risk group IEC 62471: 2006-Non-GLS under 0.98 A, this product complies to Risk group 2 (RG2) Moderate risk.

Do not stare at operating lamp, may be harmful to the eyes.

For more information, please refer to: <https://luminusdevices.zendesk.com/hc/en-us/articles/10532958752397>



Revision History

Rev	Date	Description of Change
01	05/11/2026	Initial release.
02	05/22/2026	Updated typo on Dominant wavelength bins table on page 3.