

# SP-2835-12XY

## Mid Power LED

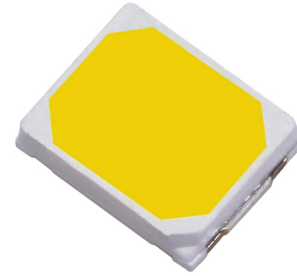

Luminus 2835 Mid-Power LEDs stand as the optimal choice for commercial lighting applications where balancing cost-effectiveness with high performance is paramount. These LEDs prioritize maximum lumens per Watt and Lumens per dollar, making them a leading solution for budget-conscious and efficiency-driven commercial lighting projects.

### Features

- 0.2W, 3V Class Mid Power LED
- Available in CCTs from 2700K to 6500K and CRIs of 80 and 90
- Industry-standard package for seamless integration into new and existing designs
- Industrial-grade package design for demanding indoor and outdoor environments
- Coating process for superior sulfur resistance



### Applications

- Ceiling lamps
- Down Lights
- Task Lighting
- Retrofit Lamps
- Panel Lighting
- Accent Lighting
- Linear Lighting
- Architectural Lighting
- Landscape Lighting
- Exterior Flood Lights

### Table of Contents

Ordering Information. ....	2
Binning Structure. ....	4
Absolute Maximum Ratings. ....	6
Characteristics. ....	7
Angular Distribution and Typical Spectrum. ....	9
Mechanical Dimensions. ....	11
Soldering Profile. ....	12
Tape and Reel Outline. ....	13
Shipping Label. ....	16
Notes. ....	17
Revision History. ....	18



## Ordering Information

### Ordering Part Numbers<sup>1,2,3,4</sup>

Minimum CRI	CCT	Luminous Flux		Ordering Part Number
		Minimum Flux (lm)	Maximum Flux (lm)	
80K	2700K	33	35	SP-2835-12XY-27-80K
90K		31	33	SP-2835-12XY-27-90K
80K	3000K	35	37	SP-2835-12XY-30-80K
90K		33	35	SP-2835-12XY-30-90K
80K	3500K	35	37	SP-2835-12XY-35-80K
90K		33	35	SP-2835-12XY-35-90K
80K	4000K	37	39	SP-2835-12XY-40-80K
90K		35	37	SP-2835-12XY-40-90K
80K	4500K	37	39	SP-2835-12XY-45-80K
90K		35	37	SP-2835-12XY-45-90K
80K	5000K	37	39	SP-2835-12XY-50-80K
90K		35	37	SP-2835-12XY-50-90K
80K	5700K	37	39	SP-2835-12XY-57-80K
90K		35	37	SP-2835-12XY-57-90K
80K	6500K	37	39	SP-2835-12XY-65-80K
90K		35	37	SP-2835-12XY-65-90K

**Notes:**

1. Test condition :  $I_f = 60 \text{ mA}$ ,  $T_c = 25^\circ\text{C}$ .
2. Ordering Part Numbers specify the full distribution of forward voltage (Vf) bins.
3. Standard ordering uses 5-step chromaticity binning (M5). For 3-step binning (M3), contact your Luminus sales representative for availability.
4. 'K' suffix denotes KSF based narrow-band red phosphor – delivers high CRI and superior color quality.



## Ordering Information

### Part Number Nomenclature

**SP**

**2835**

**12XY**

**###**

**##**

Product Family	Package Type	Package Configurator	Nominal CCT <sup>1</sup>	Minimum CRI
<b>SP:</b> 0.2W Class Mid Power Led	<b>2835:</b> 2.8 mm x 3.5 mm	<b>12XY:</b> Package code	<b>27:</b> 2700K <b>30:</b> 3000K <b>35:</b> 3500K <b>40:</b> 4000K <b>45:</b> 4500K <b>50:</b> 5000K <b>57:</b> 5700K <b>65:</b> 6500K	<b>80K:</b> CRI>80, KSF <b>90K:</b> CRI>90, KSF

**Note:**

1. Correlated Color Temperatures (CCT)



## Binning Structure

### Flux Bins<sup>1</sup>

Flux Bin	Binning @ 60 mA/20 ms pulse, $T_c = 25^\circ\text{C}$	
	Minimum Flux (lm)	Maximum Flux (lm)
X7A	31	33
X8A	33	35
X9A	35	37
X10A	37	39

### Forward Voltage Bins

Voltage Bin	Binning @ 60 mA/20 ms pulse, $T_c = 25^\circ\text{C}$	
	Minimum Voltage (V)	Maximum Voltage (V)
Y1-1	2.6	2.7
Y1-2	2.7	2.8
Y1-3	2.8	2.9
Y1-4	2.9	3.0

**Note:**

1. Products are production tested then sorted and packed by bin.



## Binning Structure

### Chromaticity Binning Diagram

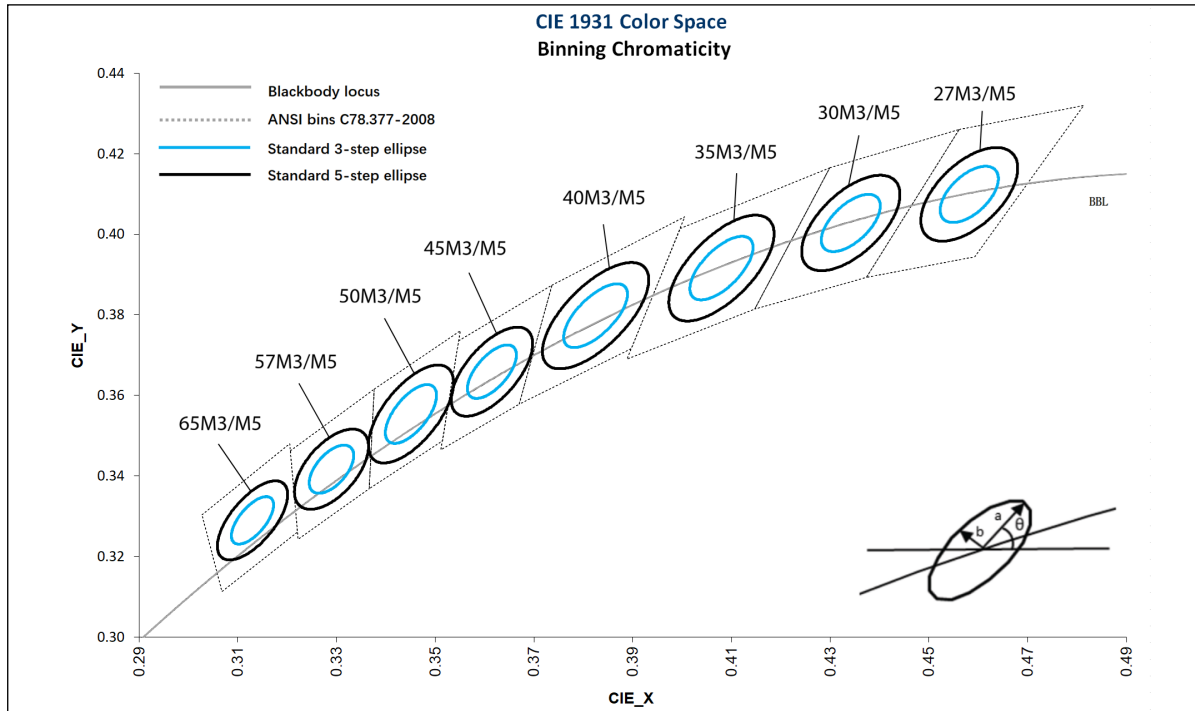

### Chromaticity Bin Definition<sup>1</sup> ( $I_f = 60 \text{ mA}$ , $T_c = 25^\circ\text{C}$ )

CCT	Center point		3-step Bin		5-step Bin		Angle (deg)
	x	y	a	b	a	b	$\Phi$
2700K	0.4582	0.4099	0.00810	0.00420	0.01350	0.00700	53.42
3000K	0.4342	0.4028	0.00834	0.00408	0.01390	0.00680	53.13
3500K	0.4080	0.3916	0.00927	0.00414	0.01545	0.00690	54.00
4000K	0.3825	0.3798	0.00939	0.00402	0.01565	0.00670	53.43
4500K	0.3615	0.3659	0.00756	0.00338	0.01260	0.00563	57.58
5000K	0.3451	0.3554	0.00822	0.00354	0.01370	0.00590	59.37
5700K	0.3290	0.3417	0.00671	0.00330	0.01118	0.00550	58.35
6500K	0.3130	0.3290	0.00669	0.00285	0.01115	0.00475	58.34

**Note:**

1. The correlated color temperature (CCT) measurement tolerance is  $\pm 150 \text{ K}$ .



## Absolute Maximum Ratings

Parameter	Symbol	Values	Unit
Forward Current	$I_f$	360	mA
Pulse Forward Current <sup>1</sup>	$I_{fp}$	450	mA
Power Dissipation	$P_d$	200	mW
Reverse Voltage	$V_r$	5	V
Junction Temperature	$T_j$	125	°C
Case Temperature	$T_c$	105	°C
Operating Temperature Range	$T_{opr}$	-40~+85	°C
Storage Temperature Range	$T_{stg}$	-40~+85	°C
Electrostatic Discharge, HBM, Class 3B in accordance with ANSI/ESDA/JEDEC JS-001	$V_{ESD}$	2000	V

**Notes:**

1. Frequency 10 kHz, duty ratio ≤10 %.
2. LEDs are rated for operation up to the specified maximum forward current and temperatures. Exceeding these limits can reduce device lifetime. To ensure LED longevity and prevent accelerated flux degradation, follow the Maximum Forward Current vs. Case Temperature derating curves provided in this data sheet.



## Characteristics

Parameter		Symbol	Value	Unit
Forward Voltage ( $I_f=60$ mA/20 ms pulse, $T_c=25^\circ\text{C}$ )	Minimum	$V_{f \text{ min}}$	2.6	V
	Maximum	$V_{f \text{ max}}$	3.0	
Reverse Current ( $V_r= -5$ V)		$I_{r \text{ max}}$	10	uA
Viewing Angle		$2\theta_{1/2}$	120	°
Typical Electrical Thermal Resistance (junction to case) <sup>1,2</sup>		$R_{\text{th J-C}}$	29	°C/W

**Notes:**

1. Thermal resistance measurement is in accordance with JEDEC 51-14.
2. Typical Electrical Thermal Resistance is defined as the ratio between temperature difference (junction to case) and electrical input power.



**Relative Luminous Flux vs Forward Current**

$T_c = 25^\circ\text{C}$

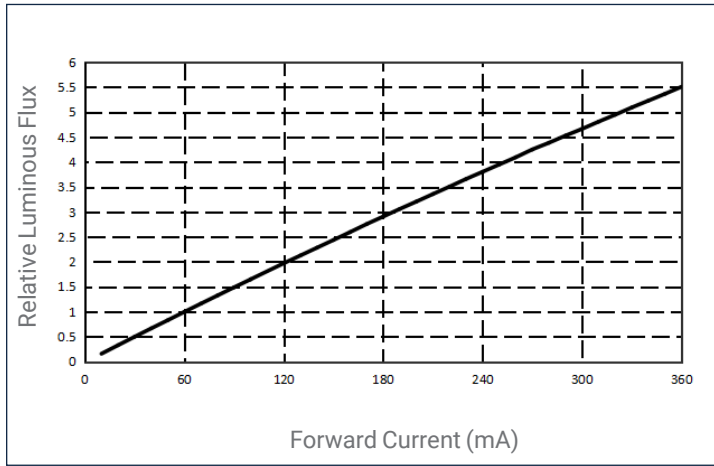

**Relative Light Output vs Case Temperature**

$I_f = 60\text{ mA}$

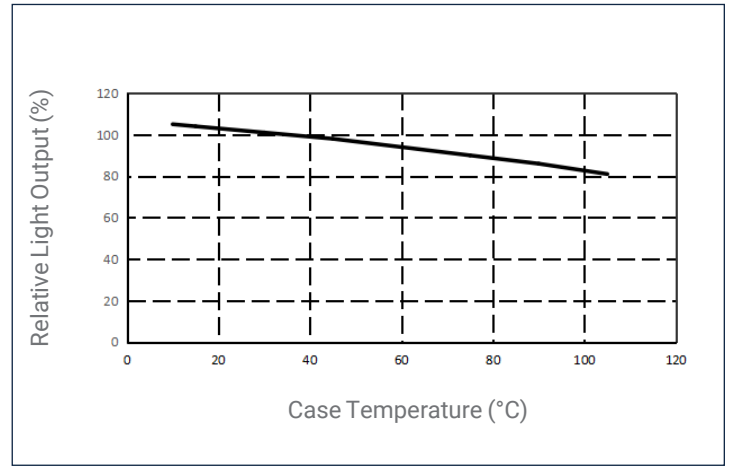

**Forward Current vs Forward Voltage**

$T_c = 25^\circ\text{C}$

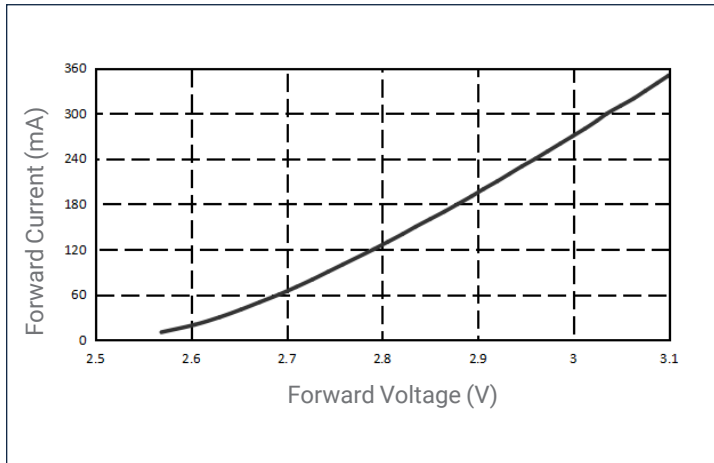

**Forward Voltage vs Case Temperature**

$I_f = 60\text{ mA}$

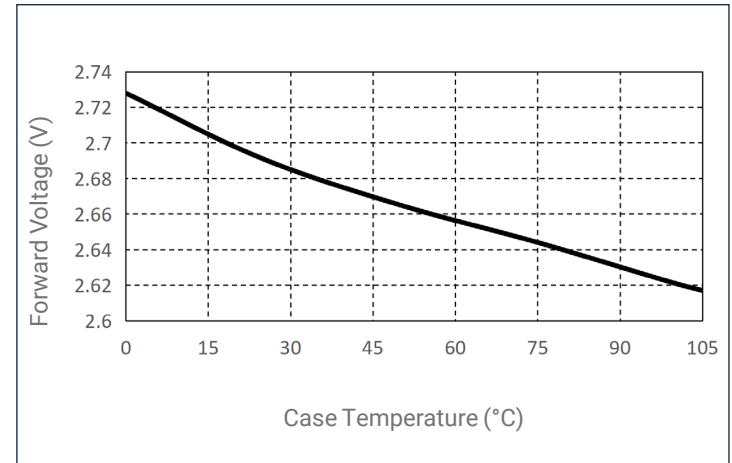

**Maximum Forward Current vs Case Temperature**

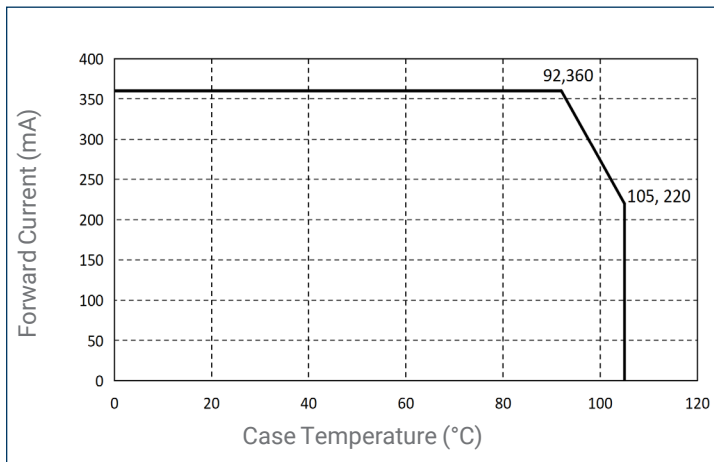



## Angular Distribution and Typical Spectrum

### Angular Distribution

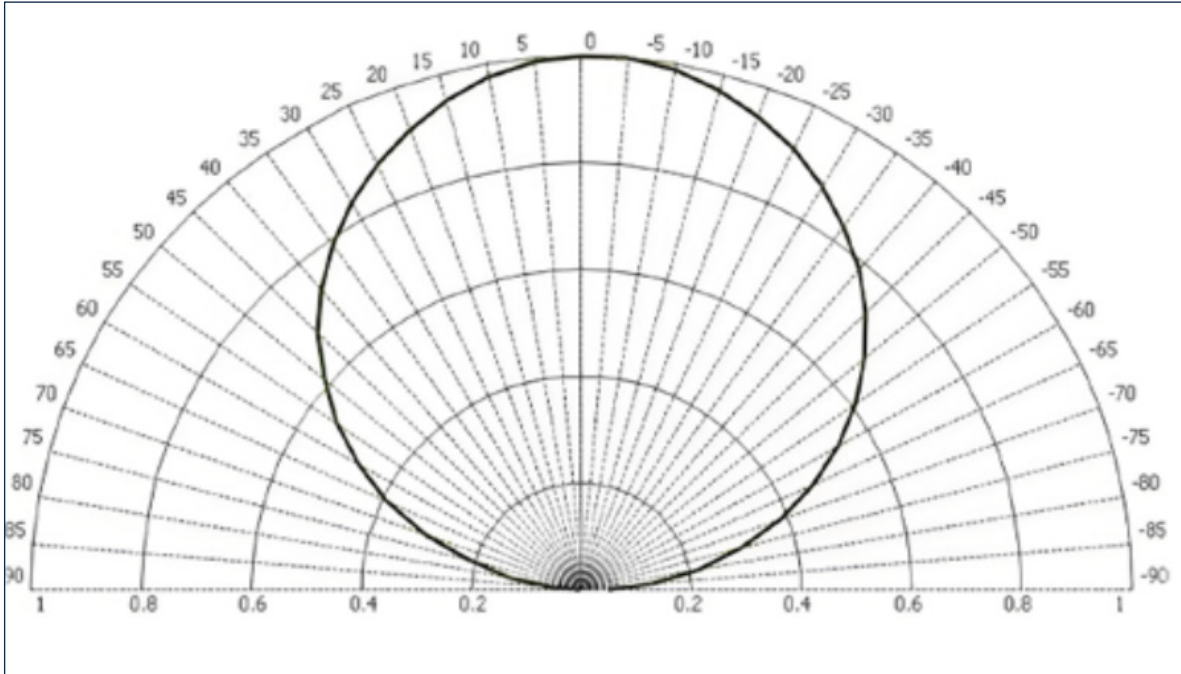

### Relative Spectral Power Distribution

$\Phi_{ref} = f(\lambda)$ ,  $I_f = 60$  mA, 20 ms single pulse,  $T_c = 25^\circ\text{C}$ , CRI 80

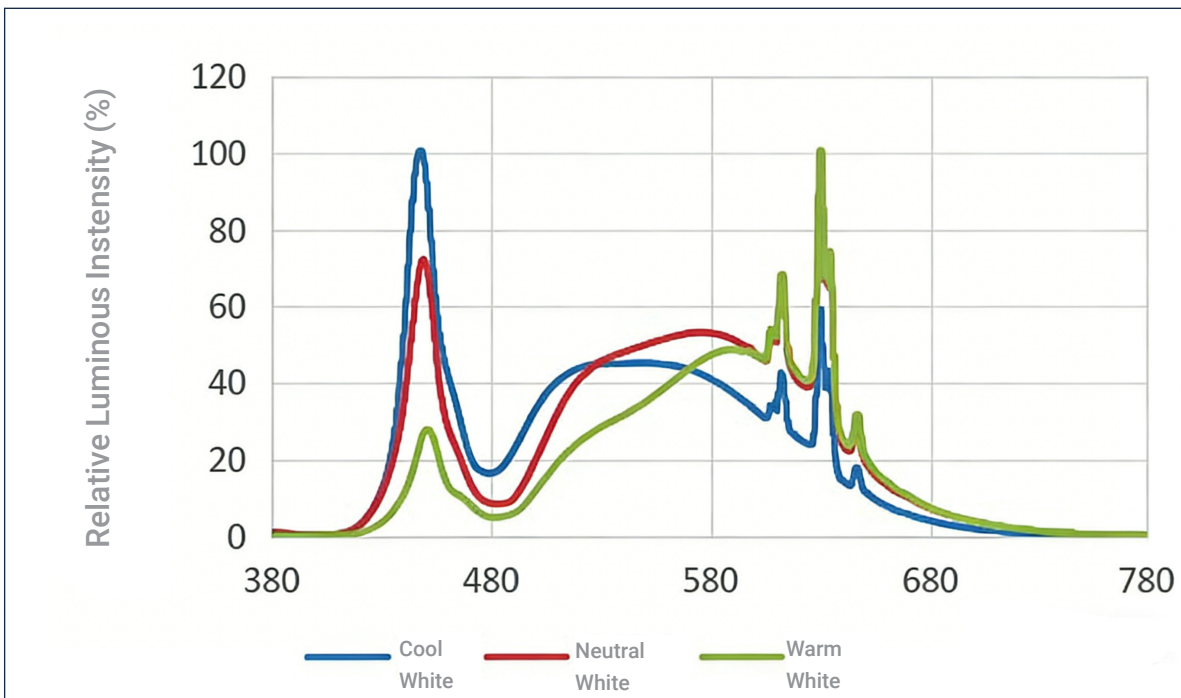



## Typical Spectrum

### Relative Spectral Power Distribution

$\Phi_{ref} = f(\lambda)$ ,  $I_f = 60$  mA, 20 ms single pulse,  $T_c = 25^\circ\text{C}$ , CRI 90

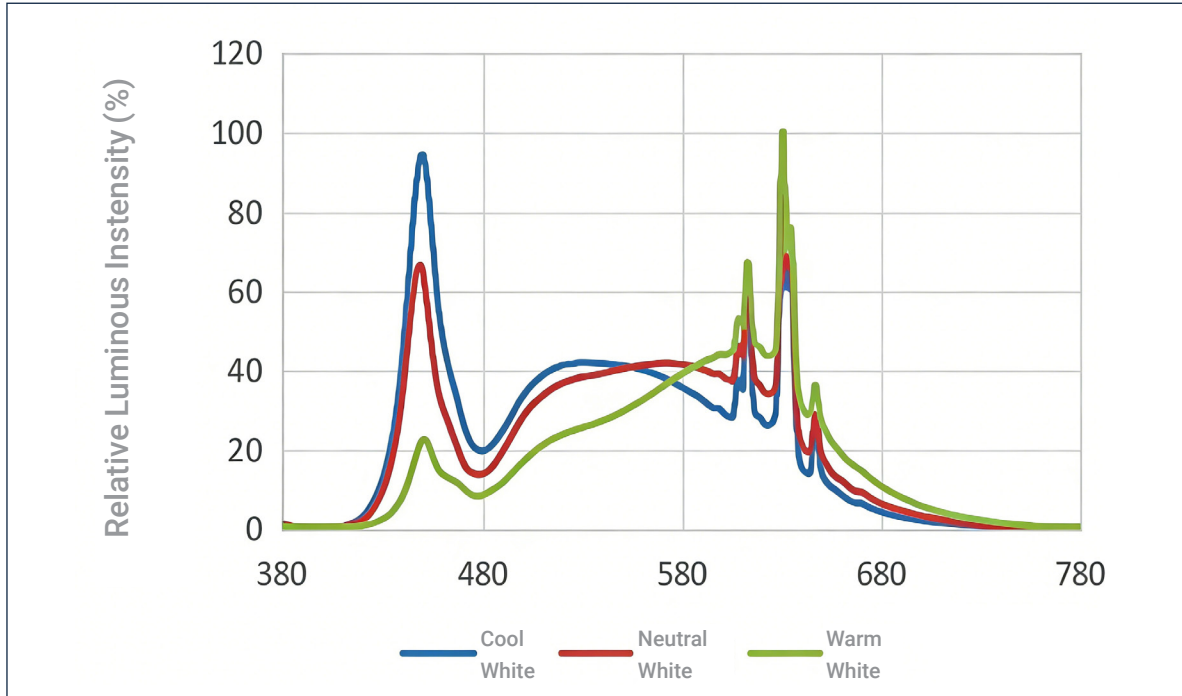



## Mechanical Dimensions<sup>1,2</sup>

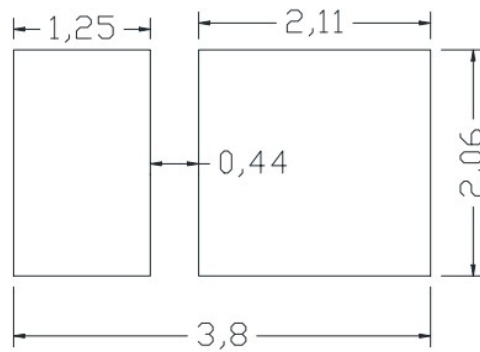
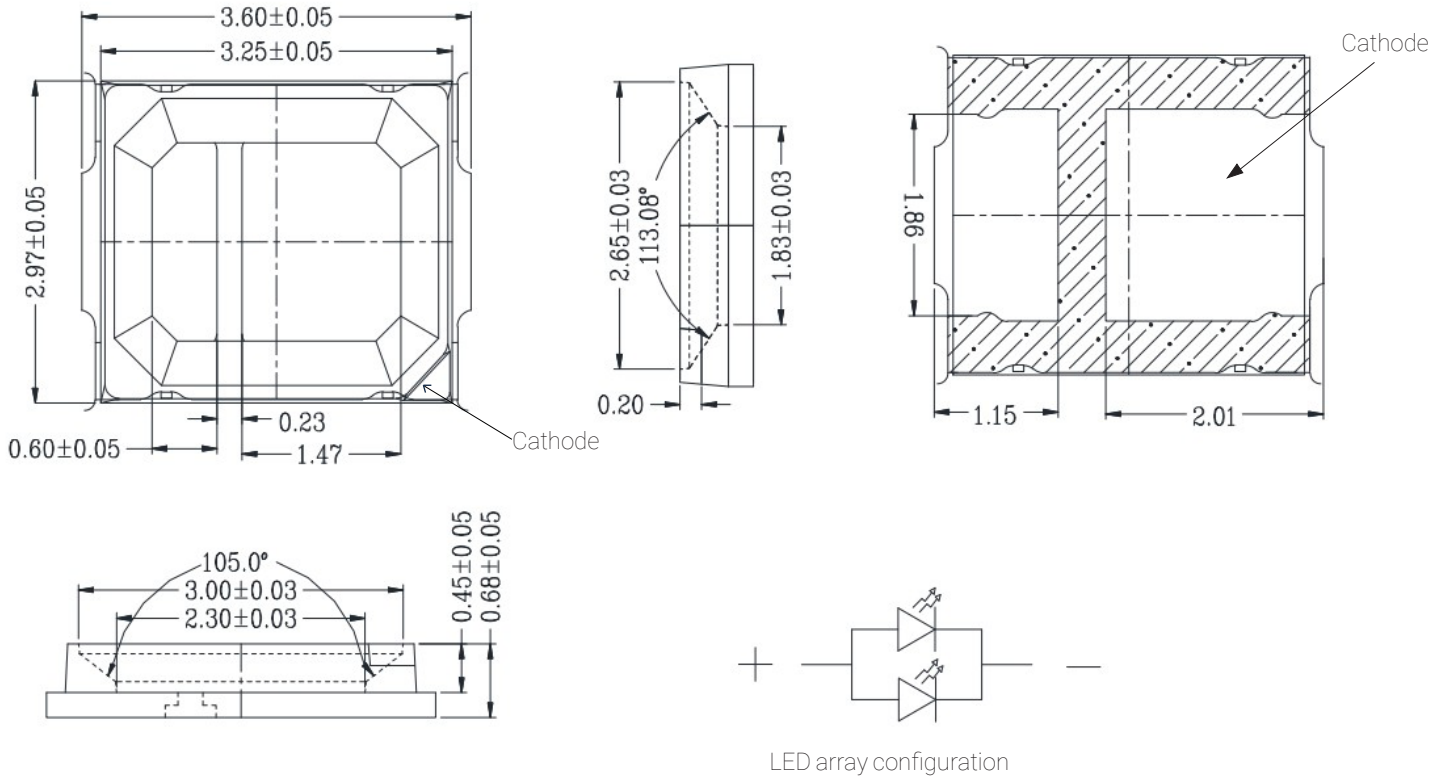

Recommended Solder Pad Design

### Notes:

1. All dimensions are in millimeter  $\pm 0.15$  mm, unless otherwise noted.
2. Lead finish: Silver plated.



## Soldering Profile

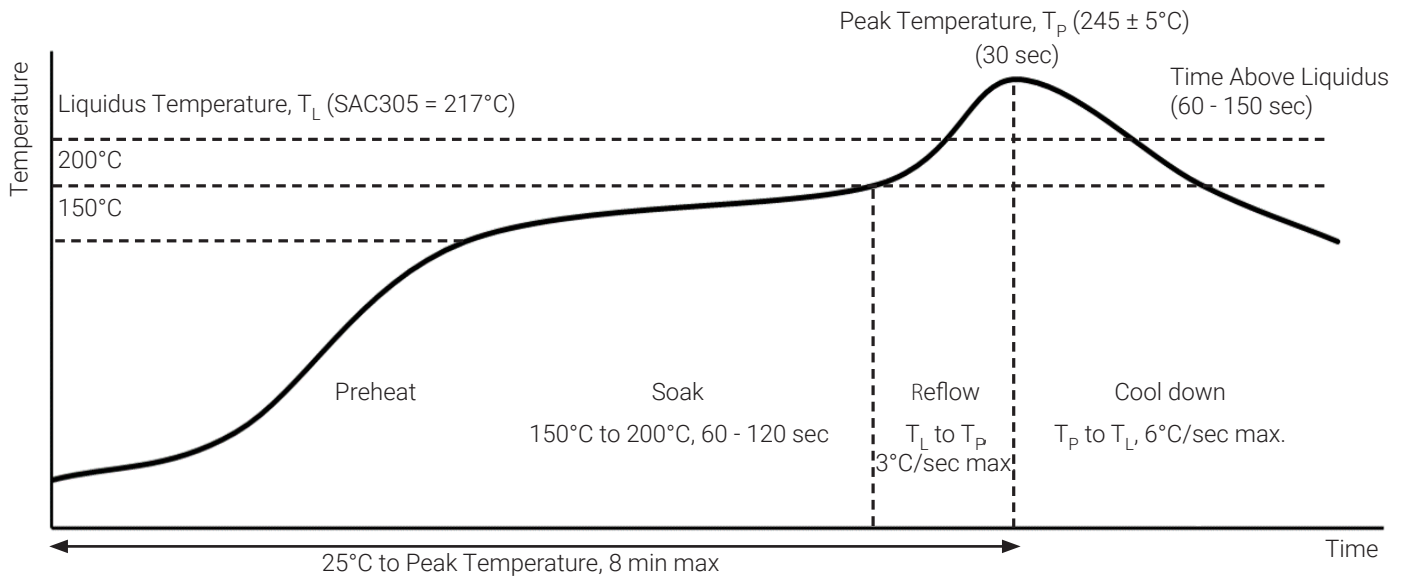

### SMT Solder Rework Temperature Guidelines

Parameter	Manual Hotplate Reflow	Hot Air Gun Reflow
Heating Time	< 60 sec	
Hotplate Temperature	< $245^\circ\text{C}$	< $150^\circ\text{C}$

#### Notes:

- The numbers in the table are specific to SAC305. Luminus recommends using an SAC305 solder paste with a no-clean flux for RoHS compliant products.
- Use of a multi-zone IR reflow oven with a nitrogen blanket is recommended.
- Time-temperature profile of the reflow process showing the four functional profile zones are defined in IPC-7801. All the temperatures refer to the application PCB measured adjacent to the package body.
- The actual profile shall be optimized per the PCB design and configuration.
- Key visual and LED performance characteristics to consider include solder bridging, solder voiding, solder balling, LED component placement or shifting, potential contamination that may impact light emissions, and the functional performance of the LED.
- Luminus recommends to use the solder paste data sheet information as a starting point in time-temperature process development.
- These are general guidelines. Consult the solder paste manufacturer's datasheet for guidelines specific to the alloy and flux combination used in your application. For more information, please refer to: <https://luminusdevices.zendesk.com/hc/en-us/articles/360060306692-How-do-I-Reflow-Solder-Luminus-SMD-Components->
- For any technical questions about soldering process, please contact Luminus at [techsupport@luminus.com](mailto:techsupport@luminus.com).



## Tape and Reel Outline

### Tape Package Dimensions

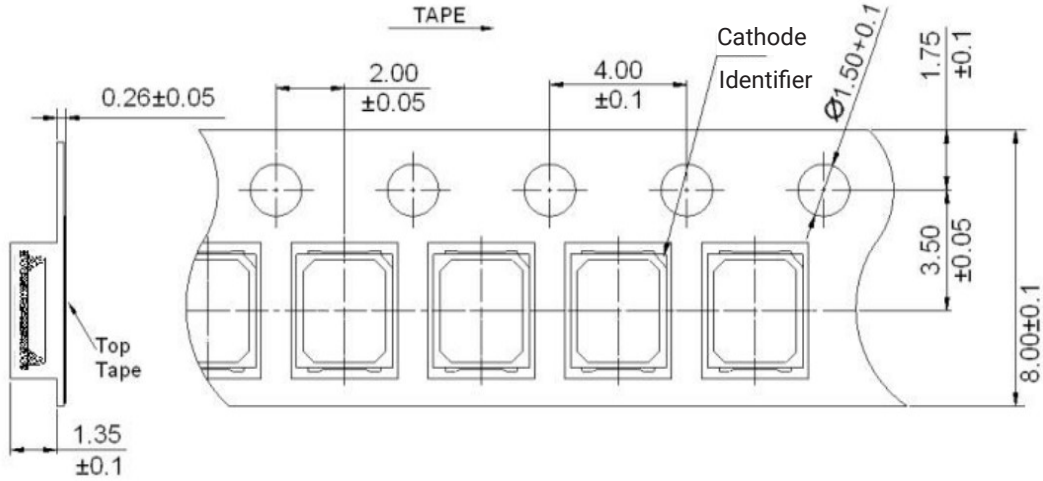

#### Notes:

1. Quantity: Max 4,000/16,000 pcs per reel. "R1" for 16,000 pcs/reel and "R2" for 4,000 pcs/reel at the end of part number.
2. Cumulative Tolerance: Cumulative Tolerance/10 pitches to be  $\pm 0.2$  mm.
3. Adhesion Strength of Cover Tape Adhesion strength to be 0.1-0.7 N when the cover tape is turned off from the carrier tape at the angle of  $10^\circ$  to the carrier tape.
4. Package: P/N, Manufacturing data Code No. and Quantity to be indicated on a damp proof package.
5. All dimensions are in millimeter.



## Tape and Reel Outline

### Reel Package Dimensions<sup>1</sup>

4,000 pcs/reel - R2

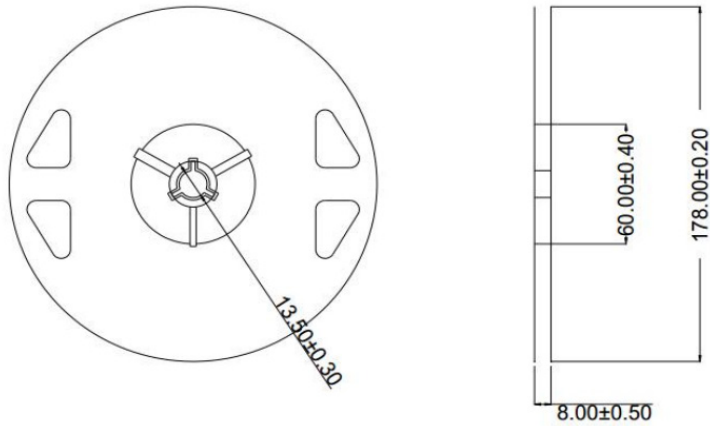

16,000 pcs/reel - R1

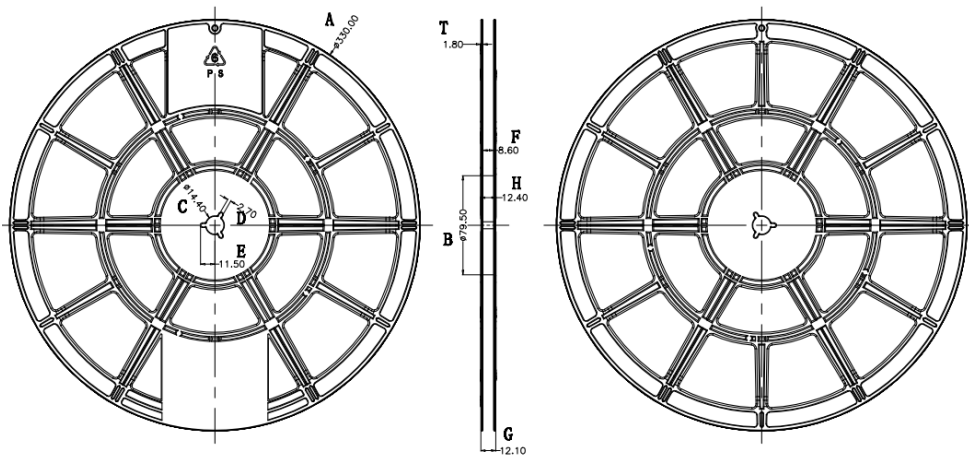

A±0.2	B±0.5	C±0.2	D±0.2	E±0.2	F±0.3	G±0.5	H±0.5	T±0.2
∅330	∅79.5	∅14.4	2.7	11.5	8.6	12.1	12.4	1.8

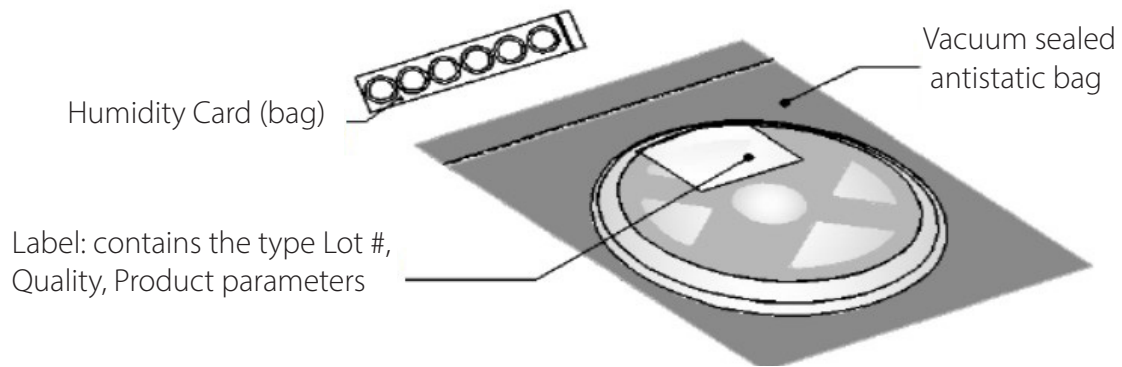
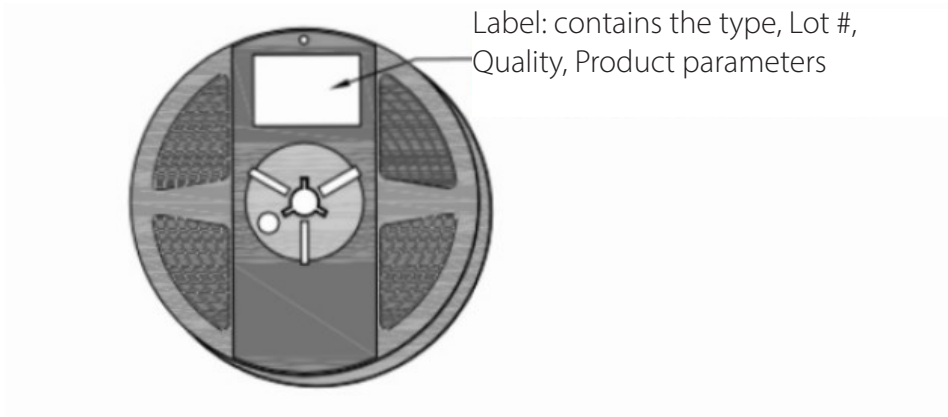

**Note:**

1. All dimensions are in millimeter.



## Shipping Label

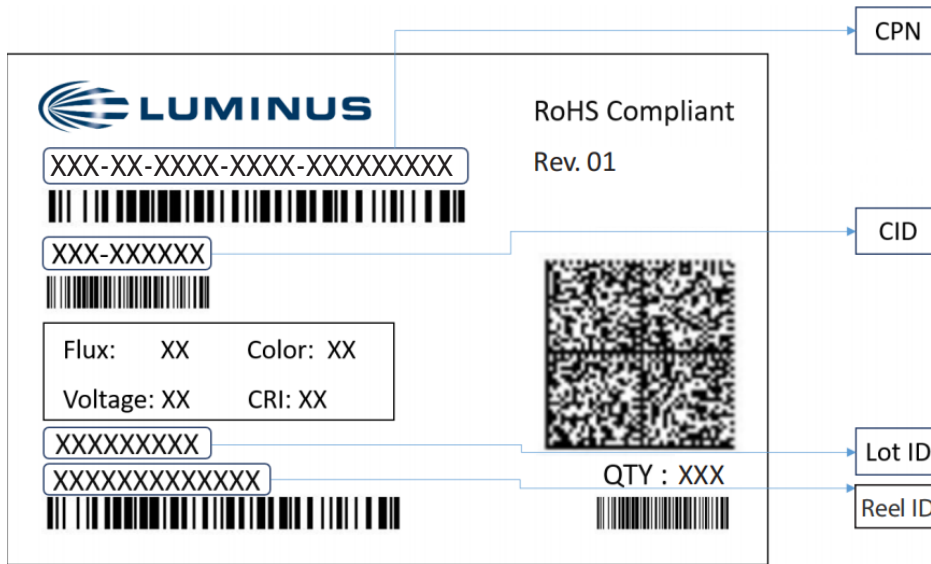

### Label Fields:

- CPN: Luminus ordering part number
- CID: Customer's part number (this is a non-essential item)
- QTY: Quantity of parts per reel
- Flux: Bin as defined on page 4
- Voltage: Bin as defined on page 4
- Color: Bin as defined on page 5
- CRI: NA
- Lot ID & Reel ID: For Luminus internal use

### Packing Configuration:

- 4,000/16,000 units per reel
- Each reel is placed in an anti-static moisture barrier bag
- Partial reel may be shipped
- Shipping label is placed on top of each packaging box



## Notes

### Static Electricity

1. The products are sensitive to static electricity, and care should be taken when handling them.
2. Static electricity or surge voltage will damage the LEDs. It is recommended to wear an anti-electrostatic wristband or an anti-electrostatic gloves when handling the LEDs.
3. All devices, equipment and machinery must be properly grounded. It is recommended that measures be taken against surge voltage to the equipment that mounts the LEDs.

### Storage

1. Moisture Sensitivity Rating:
    - The LEDs have an MSL 3 (Moisture Sensitivity Level) rating.
    - Adhere to the guidelines specified in JEDEC J-STD-033 for safe handling.
  2. Temperature and Humidity:
    - Store the LEDs in an environment with the following conditions:
      - Temperature: Lower than 30°C (86°F)
      - Relative Humidity: Lower than 85%
      - Maintaining these conditions helps prevent moisture-related issues.
  3. Moisture-Proof Packaging:
    - When storing the LEDs, use moisture-proof packaging.
    - Include absorbent material (such as silica gel) within the package further protects against moisture ingress.
- By following these guidelines, you can ensure the longevity and reliability of the LEDs.



## Revision History

Rev	Date	Description of Change
01	10/22/2025	Initial release
02	12/26/2025	Update maximum current
03	01/30/2026	Update flux bins and characteristic plots
04	03/12/2026	Update features and maximum forward current