

# SST-20-WG (CRI > 90)

## High Power White LEDs

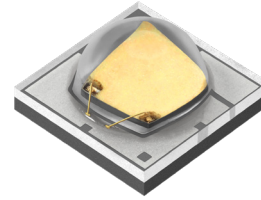

### Features

- High CRI, high-efficacy white LEDs for high-performance directional lighting applications.
- The vertical chip features high lumen density and small emitting angle, ideal for maximizing the light intensity and reducing the optics size in optical beam shaping.
- The phosphor-on-chip technology delivers high color uniformity over radiation angle, enabling superior light quality for beam spots.
- LM-80 10,000-hr test data available, excellent TM-21 lifetime and color stability
- Maximum Drive Current: 2.0 A
- Color Temperature: 4000K, 5000K, 5700K
- Color Rendering Index: > 90
- Low thermal resistance: 1.6°C/W
- ANSI-compatible chromaticity bins
- Electrically isolated thermal path
- 8 kV HBM ESD rating per ANSI/ESDA/JEDEC JS-001



### Applications

- Wall Washer
- Track Light
- Spotlight
- Task Light
- Miniature Recessed Lights
- Landscape Lighting
- Portable Lighting
- Stage & Studio Lighting

### Table of Contents

Ordering Information.....	2
Binning Structure.....	3
Absolute Maximum Ratings.....	6
Product Characteristics.....	6
Soldering Profile.....	9
Mechanical Dimensions.....	10
Tape and Reel Outline.....	12
Shipping Label.....	13
Packaging.....	14
Notes.....	15



## Ordering Information

### Ordering Part Numbers<sup>1</sup>

CRI	CCT	Luminous Flux		Solder Pad Type <sup>3</sup>	Ordering Part Numbers
		Minimum Flux Bin <sup>1</sup>	Minimum Flux <sup>2</sup>		Chromaticity Bin Kit ANSI Centers <sup>4</sup>
> 90	4000K	C8	238 lm	A	SST-20-WG40-A2-C8402
				B	SST-20-WG40-B2-C8402
		C9	250 lm	A	SST-20-WG40-A2-C9402
				B	SST-20-WG40-B2-C9402
	5000K	C9	250 lm	A	SST-20-WG50-A2-C9502
				B	SST-20-WG50-B2-C9502
		D1	265 lm	A	SST-20-WG50-A2-D1502
				B	SST-20-WG50-B2-D1502
	5700K	C9	250 lm	A	SST-20-WG57-A2-C9572
				B	SST-20-WG57-B2-C9572
		D1	265 lm	A	SST-20-WG57-A2-D1572
				B	SST-20-WG57-B2-D1572

### Part Number Nomenclature

SST

20

W<yxx>

<p#>

<ffccc>

Product Family	Chip Area	Color	Package Configuration	Bin Kit
<b>S:</b> Surface Mount <b>S:</b> Dome Lensed <b>T:</b> Single Emitter	<b>20:</b> 2.0 mm <sup>2</sup>	<b>W:</b> White <b>&lt;y&gt;</b> CRI Category Code <b>G:</b> CRI>90 <b>&lt;xx&gt;</b> Color Temperature <b>40:</b> 4000K <b>57:</b> 5700K	<b>&lt;p&gt;</b> Solder Pad Configuration <b>A:</b> type A - see page 10 <b>B:</b> type B - see page 11 <b>&lt;#&gt;</b> Chip Generation <b>2:</b> Gen 2	<b>&lt;ff&gt;</b> Minimum Flux Bin, see 'Luminous Flux Binning' table for details <b>&lt;ccc&gt;</b> Chromaticity Bin Kit, see 'Chromaticity Bin Kit Codes' table for details

#### Note:

- The Ordering Part Number specifies the Minimum Flux Bin in shipment; higher flux bins may be shipped without advance notice. Please refer to 'Luminous Flux Binning' table for details of all flux bins.
- Product test condition:  $I_f = 700 \text{ mA}$ ,  $T_j = 85^\circ\text{C}$ .
- See 'Mechanical Dimensions' for A and B types' solder pad configurations. All product mechanical, electrical and optical specifications are otherwise identical.
- Shipments always adhere to the color bins specified in each Chromaticity Bin Kit. See 'Chromaticity Bin Kit Codes' table for the color bins included in each Bin Kit.



## Binning Structure

### Luminous Flux Binning<sup>1,2</sup>

Flux Bin Code	Binning @ 700 mA			Correlated Minimum Flux (lm) @ $T_j=85^\circ\text{C}^2$			
	$T_j=85^\circ\text{C}$		$T_j=25^\circ\text{C}$				
	Minimum Flux (lm)	Maximum Flux (lm)	Minimum Flux (lm)	350 mA	1000 mA	1500 mA	2000 mA
C8	238	250	262	129	324	450	559
C9	250	265	275	135	340	473	588
D1	265	280	292	143	360	501	623
D2	280	295	308	151	381	529	658
D3	295	310	325	159	401	558	693

### Forward Voltage Binning<sup>3</sup>

Voltage Bin Code <sup>3</sup>	Binning @ 700 mA, $T_j=85^\circ\text{C}$	
	Minimum Voltage (V)	Maximum Voltage (V)
VH	2.5	2.7
VJ	2.7	2.9
VK	2.9	3.1

**Note:**

- LEDs are measured at 25°C ambient temperature with 700 mA 20 ms single pulse. The measured values are correlated to values at 85°C junction temperature ( $T_j$ ). Luminus maintains a  $\pm 6\%$  tolerance on flux measurement.
- Flux values at other junction temperature ( $T_j$ ) and/or forward current conditions are calculated and for reference only.
- Individual voltage bins are not orderable.



## Binning Structure

### Chromaticity Binning Coordinates

CCT	Bin Code	CIE <sub>x</sub>	CIE <sub>y</sub>	Bin Code	CIE <sub>x</sub>	CIE <sub>y</sub>	Bin Code	CIE <sub>x</sub>	CIE <sub>y</sub>	Bin Code	CIE <sub>x</sub>	CIE <sub>y</sub>
4000K	FA3	0.3744	0.3685	FB4	0.3763	0.3760	FC1	0.3825	0.3798	FD2	0.3804	0.3721
		0.3763	0.3760		0.3782	0.3837		0.3847	0.3877		0.3825	0.3798
		0.3825	0.3798		0.3847	0.3877		0.3912	0.3917		0.3887	0.3836
		0.3804	0.3721		0.3825	0.3798		0.3887	0.3836		0.3863	0.3758
5000K	DA	0.3371	0.3490	DB	0.3376	0.3616	DC	0.3463	0.3687	DD	0.3451	0.3554
		0.3451	0.3554		0.3463	0.3687		0.3551	0.3760		0.3533	0.3620
		0.3440	0.3427		0.3451	0.3554		0.3533	0.3620		0.3515	0.3487
		0.3366	0.3369		0.3371	0.3490		0.3451	0.3554		0.3440	0.3427
5700K	CA	0.3215	0.3350	CB	0.3207	0.3462	CC	0.3290	0.3538	CD	0.3290	0.3417
		0.3290	0.3417		0.3290	0.3538		0.3376	0.3616		0.3371	0.3490
		0.3290	0.3300		0.3290	0.3417		0.3371	0.3490		0.3366	0.3369
		0.3222	0.3243		0.3215	0.3350		0.3290	0.3417		0.3290	0.3300



## Binning Structure

### Chromaticity Binning Diagram<sup>1</sup>

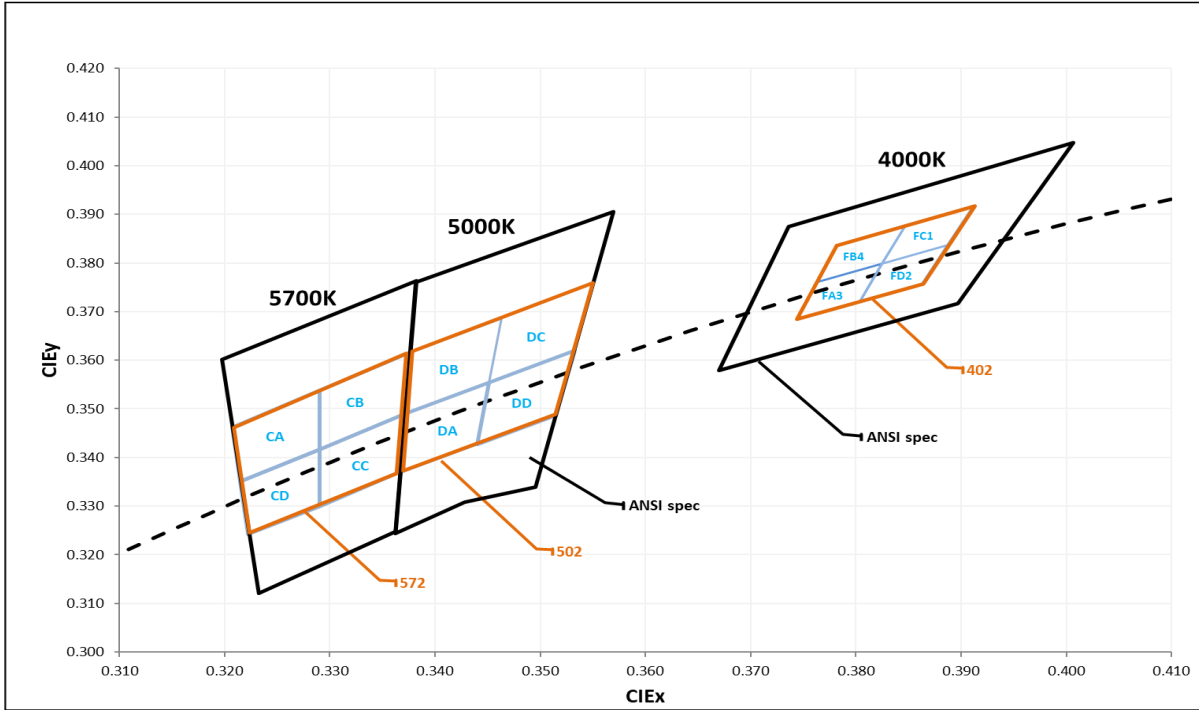

### Chromaticity Bin Kit Codes

CCT	Bin Kit	Chromaticity Bins
4000K	402	FA3, FB4, FC1, FD2
5000K	502	DA, DB, DC, DD
5700K	572	CA, CB, CC, CD

**Note:**

- LED chromaticity is measured and binned at 25°C ambient temperature with 700 mA 20 ms single pulse.
- Luminus maintains a tolerance of  $\pm 0.005$  on Chromaticity (CIE<sub>x</sub>, CIE<sub>y</sub>) measurement.



## Absolute Maximum Ratings

		Symbol	Values	Unit
DC Forward Current	Minimum	$I_{f\ min}$	0.1	A
	Maximum	$I_{f\ max}$	2.0	
Surge Current (t<10 ms, Duty Cycle < 10%)		$I_s$	3.0	A
Reverse Voltage (@ $I_f = 10\ mA$ )		$V_r$	5	V
Power Dissipation		$P_D$	7	W
Junction Temperature		$T_{j\ max}$	150	°C
Operating Temperature		$T_{opr}$	-40 to 100	°C
Storage Temperature		$T_{stg}$	-40 to 100	°C
ESD withstand Voltage HBM Per ANSI/ESDA/JEDEC JS-001		$V_{HBM}$	8	kV
ESD withstand Voltage CDM Per ANSI/ESDA/JEDEC JS-002		$V_{CDM}$	1	kV

## Product Characteristics

Parameter		Symbol	Value	Unit
Color Rendering Index <sup>1</sup> ( $T_j = 85^\circ\text{C}$ )		CRI	> 90	
Viewing Angle (FWHM)		$2\theta_{1/2}$	120	°
Forward Voltage ( $I_f = 700\ mA$ , $T_j = 85^\circ\text{C}$ )	Minimum	$V_{f\ min}$	2.5	V
	Typical	$V_{f\ typ}$	2.8	
	Maximum	$V_{f\ max}$	3.1	
Temperature Coefficient of Voltage		$\partial_{V_f}/\partial_T$	-1.13	mV/°C
Thermal Resistance (Electrical) Junction/Solder Point		$R_{thjs-EL}$	1.6	°C/W

**Note:**

1. Luminus maintains a tolerance of  $\pm 2$  on Color Rendering Index (CRI) measurement.



### Relative Luminous Flux

Forward Current:  $\phi_v/\phi_v(0.7\text{ A}), T_j = 85^\circ\text{C}$

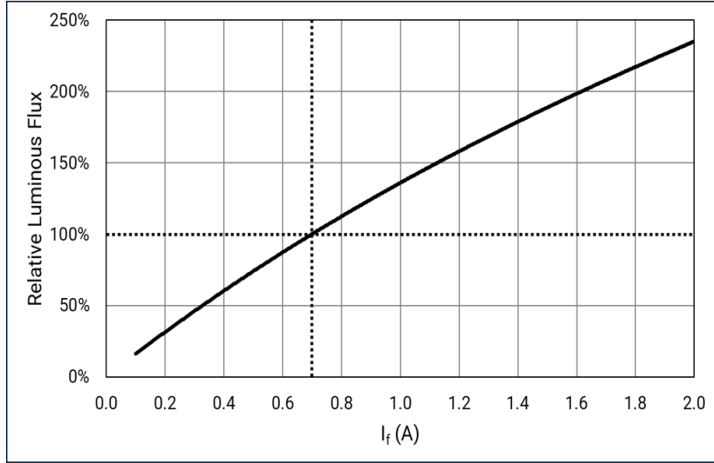

Temperature ( $T_j$ ):  $\phi_v/\phi_v(85^\circ\text{C}), I_f = 0.7\text{ A}$

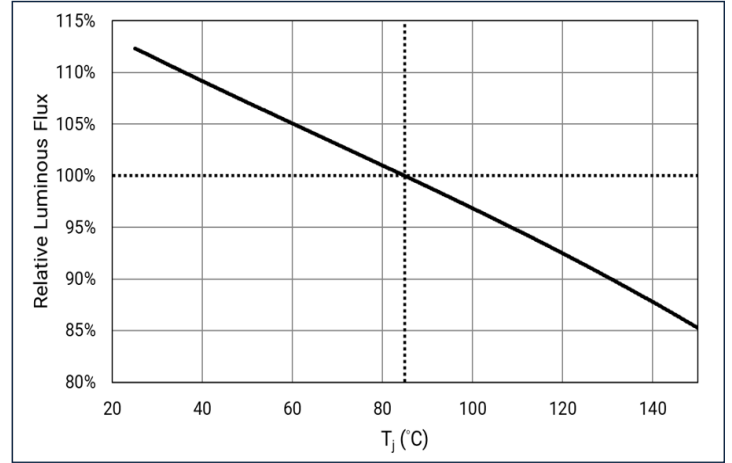

### Forward Voltage

Forward Current:  $\Delta V_f = V_f(I_f) - V_f(0.7\text{ A}), T_j = 85^\circ\text{C}$

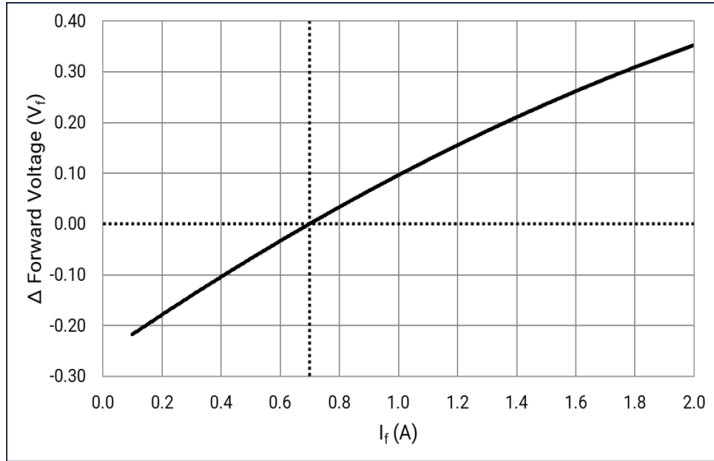

Temperature ( $T_j$ ):  $\Delta V_f = V_f(T_j) - V_f(85^\circ\text{C}), I_f = 0.7\text{ A}$

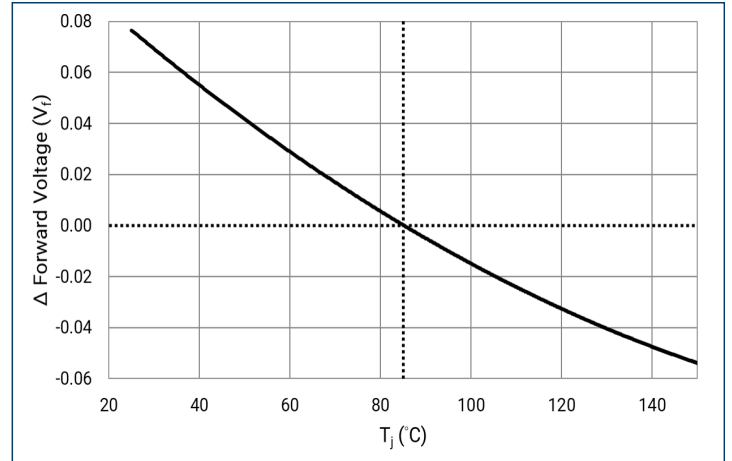

### Relative Chromaticity

Forward Current:  $\Delta \text{CIEx,y} = \text{CIEx,y}(I_f) - \text{CIEx,y}(0.7\text{ A}), T_j = 85^\circ\text{C}$

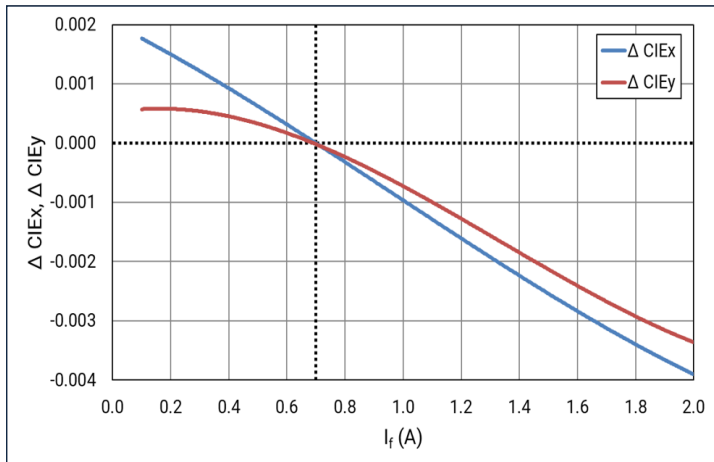

Temperature ( $T_j$ ):  $\Delta \text{CIEx,y} = \text{CIEx,y}(T_j) - \text{CIEx,y}(25^\circ\text{C}), I_f = 0.7\text{ A}$

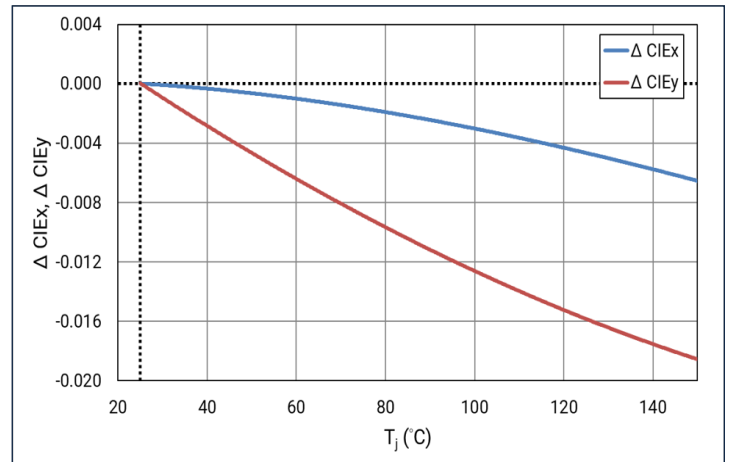



### Angular Distribution

$I_f = 0.7 \text{ A}; T_j = 25^\circ\text{C}$

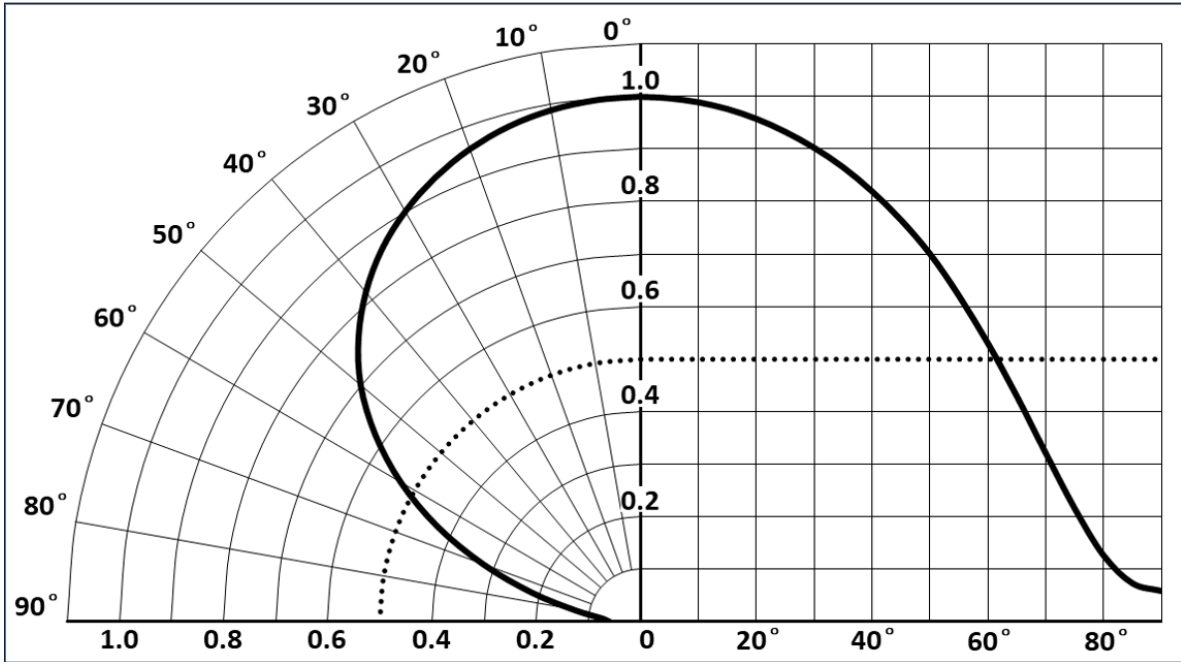

### Relative Spectral Power Distribution

$I_f = 0.7 \text{ A}; T_j = 85^\circ\text{C}$

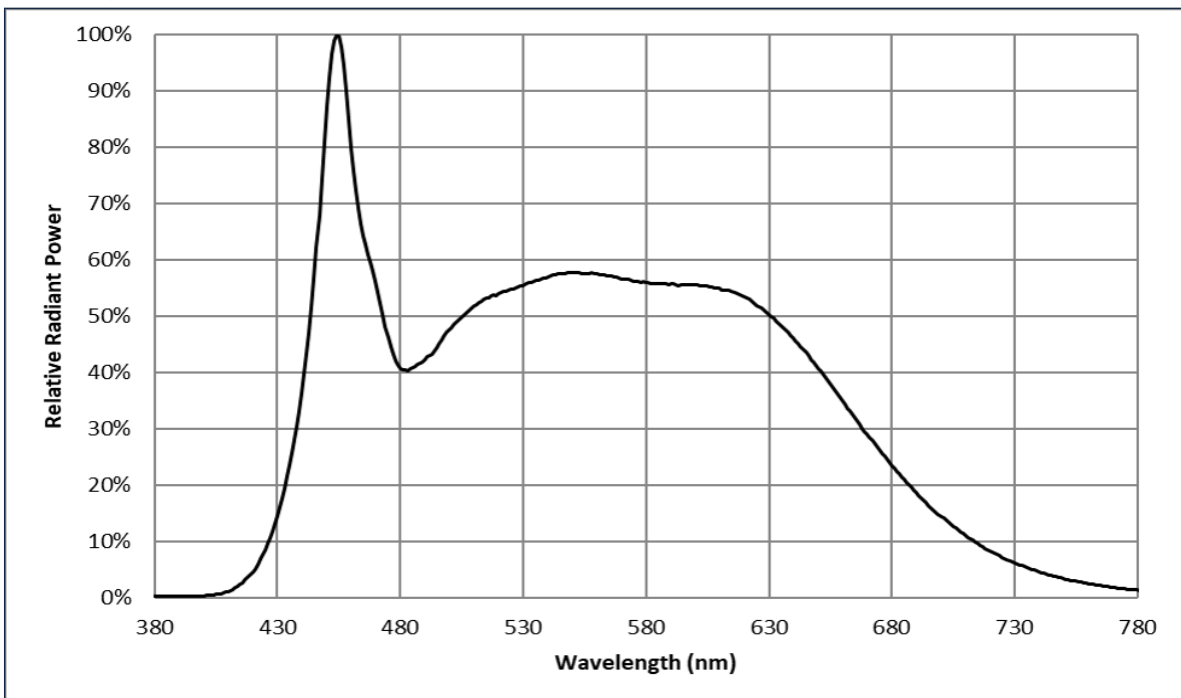





## Soldering Profile

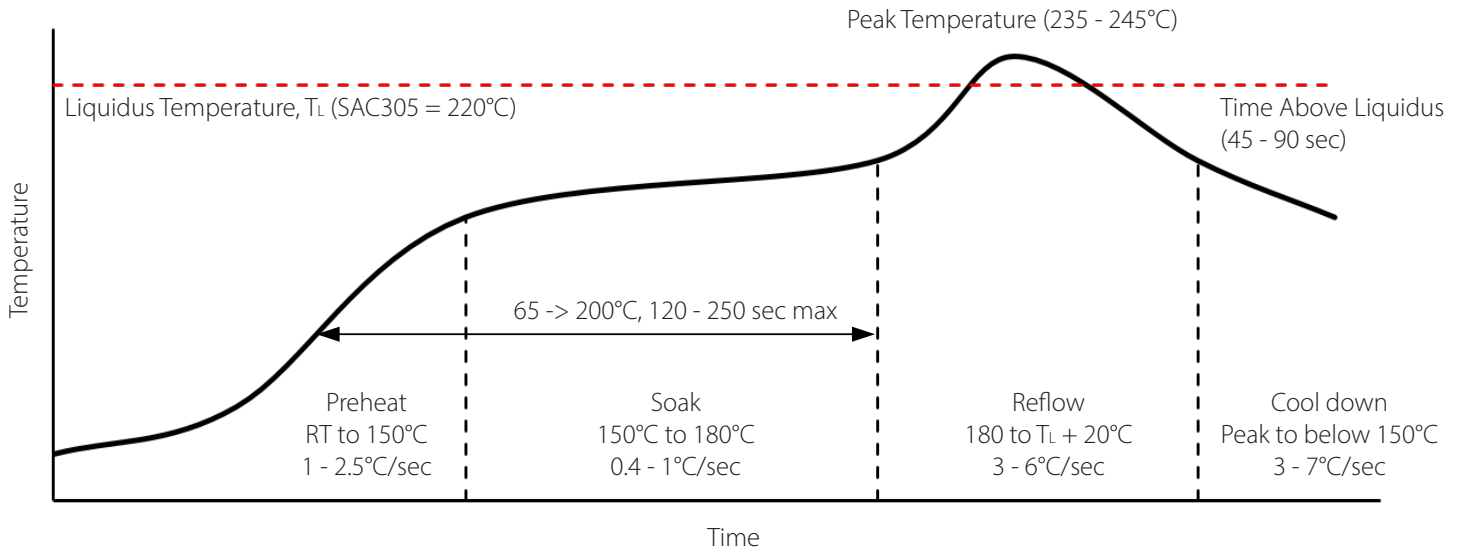

SMT Rework Guideline	Manual Hotplate Reflow	Hot Air Gun Reflow
Heating Time		< 60 sec
Hotplate Temperature	< 245°C	< 150°C

**Note:**

- Product complies to Moisture Sensitivity Level 3 (MSL 3).
- The numbers in the table are specific to SAC305. Luminus recommends using an SAC305 solder paste with a no-clean flux for RoHS compliant products.
- During the pick and place process, axial forces on the dome (or window) should not exceed 0.5 Newtons (N).
- Use of a multi-zone IR reflow oven with a nitrogen blanket is recommended.
- Time-temperature profile of the reflow process showing the four functional profile zones are defined in IPC-7801. Temperature is referenced to the center of the PCB.
- Luminus recommends to use the solder paste data sheet information as a starting point in time-temperature process development.
- These are general guidelines. Consult the solder paste manufacturer's datasheet for guidelines specific to the alloy and flux combination used in your application. For more information, please refer to: <https://luminusdevices.zendesk.com/hc/en-us/articles/360060306692-How-do-I-Reflow-Solder-Luminus-SMD-Components->
- For any technical questions about soldering process, please contact Luminus at techsupport@luminus.com.



## Mechanical Dimensions - Type A Solder Pad<sup>1</sup>

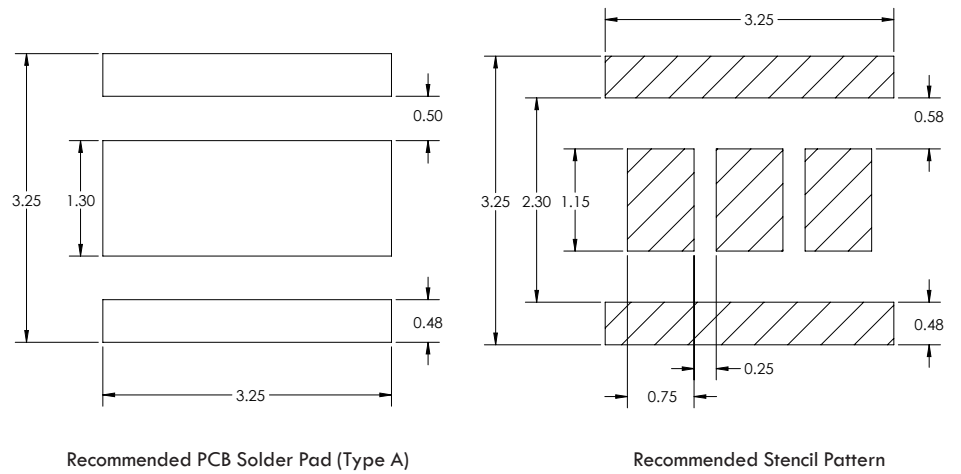
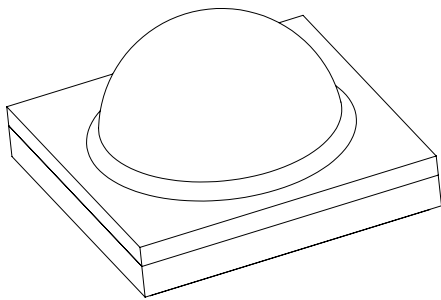
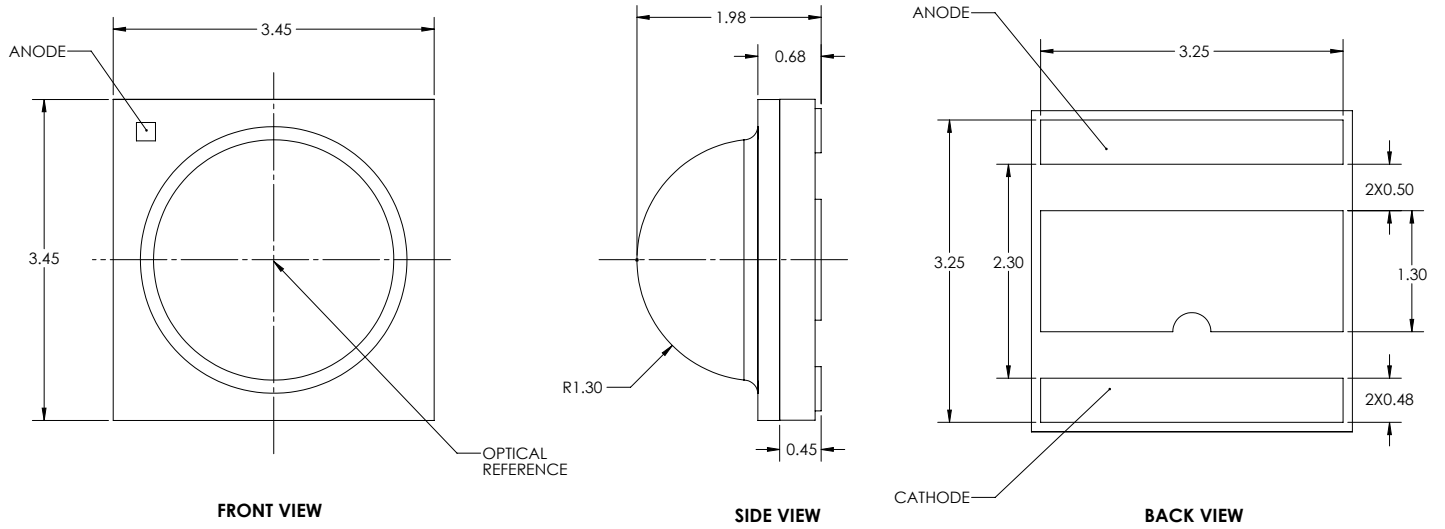

**Note:**

1. All dimensions are in millimeter  $\pm 0.13$  mm.



## Mechanical Dimensions - Type B Solder Pad<sup>1</sup>

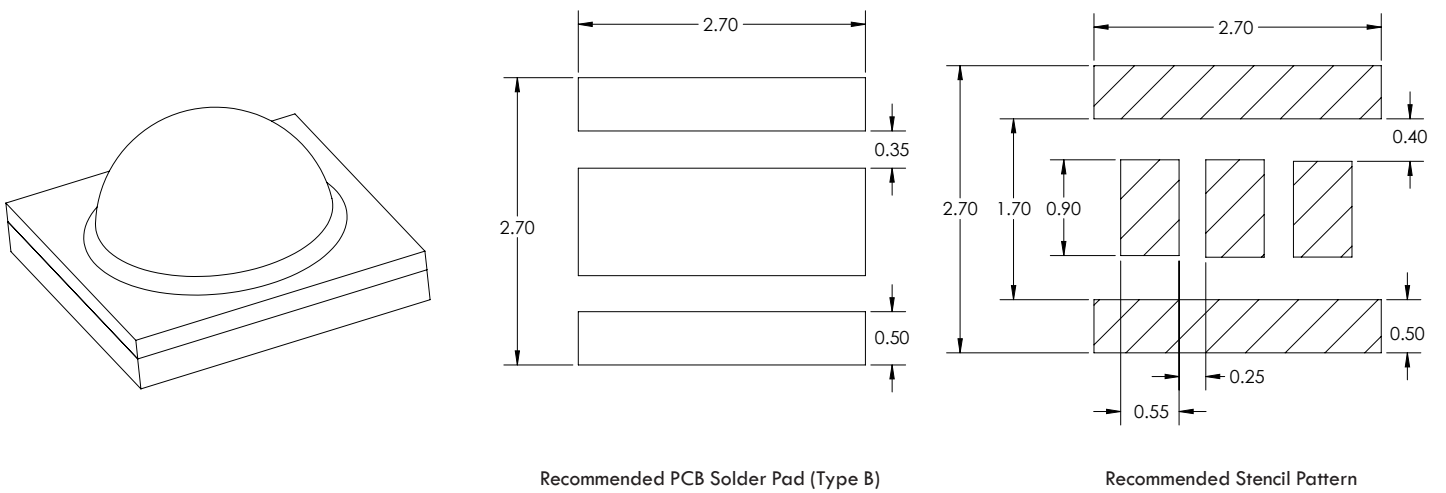
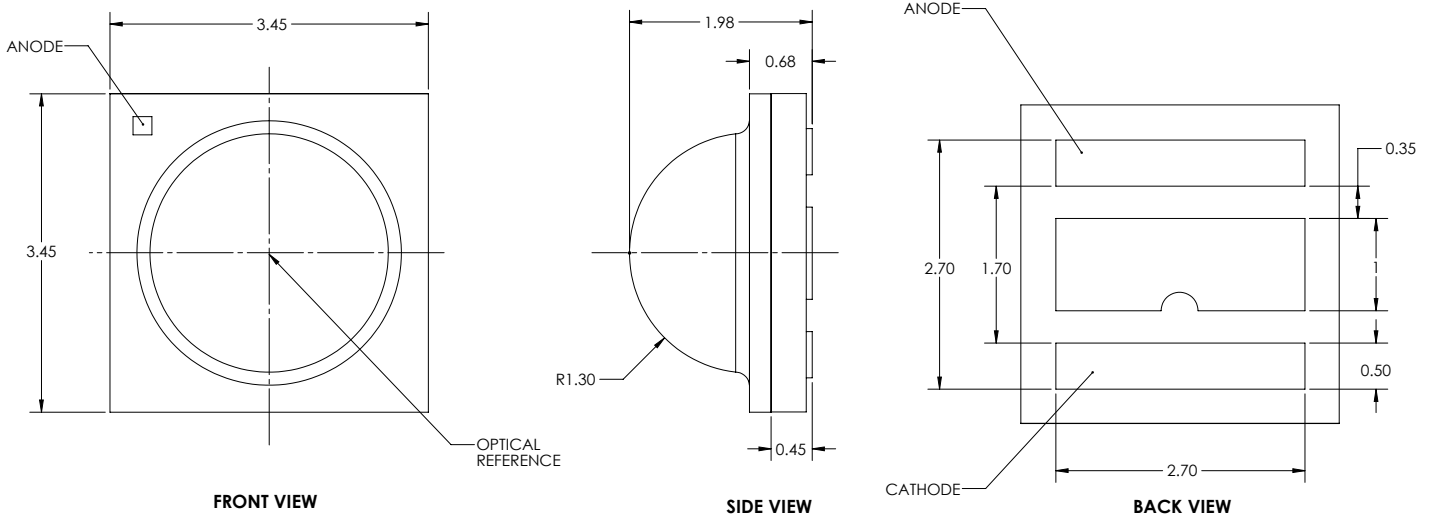

**Note:**

1. All dimensions are in millimeter  $\pm 0.13$  mm.



## Tape and Reel Outline

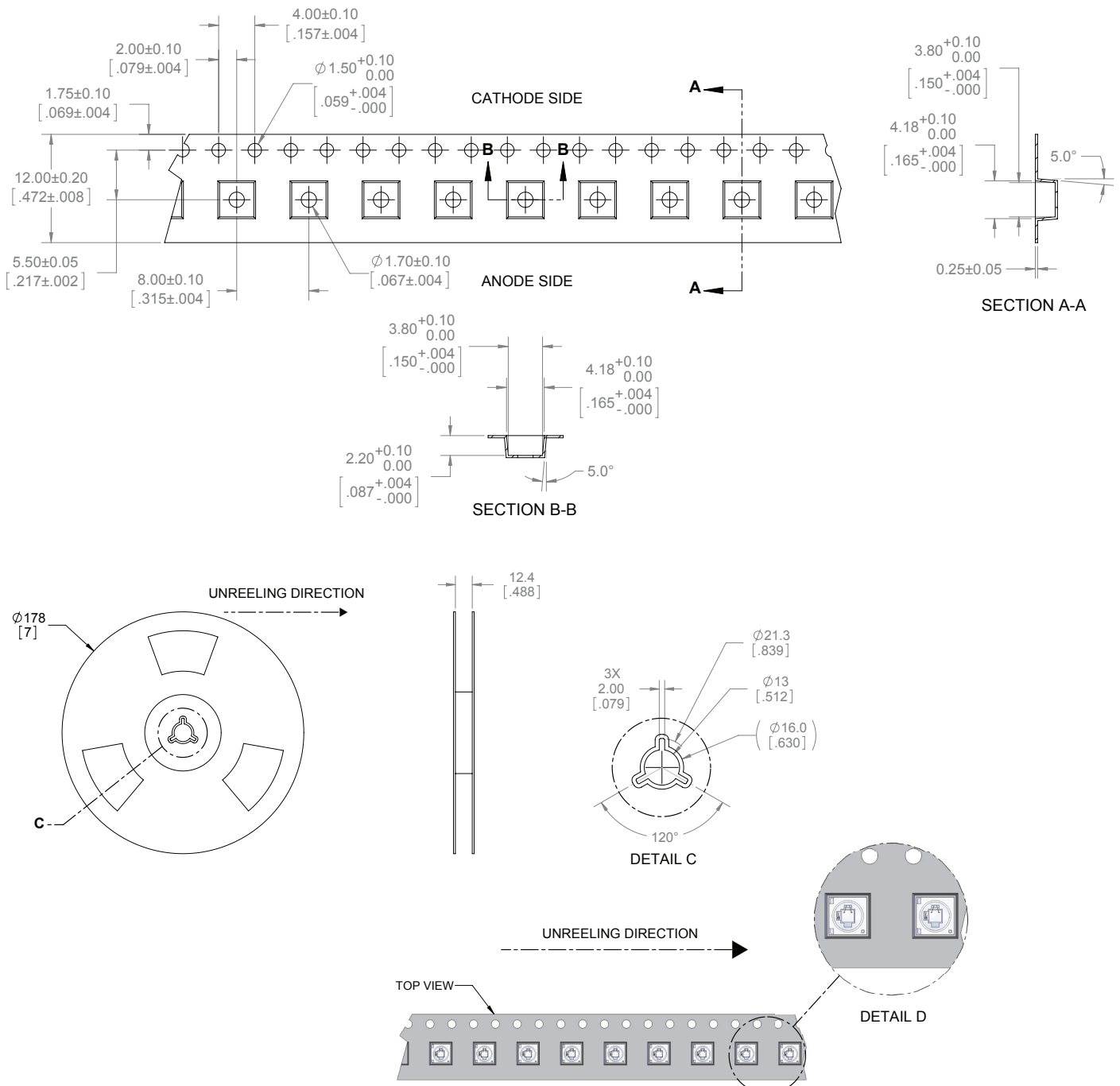

**Note:**

1. Each reel contains 1,000 units.
2. Leave 160 mm of type empty for lead in (20 empty pockets).
3. Leave 480 mm of type empty for trailer (60 empty pockets).
4. Must comply to EIA-481-C-2003.
5. Final tape and reel packaging must meet the requirements of JEDEC-STD-033, LEVEL 2A.



## Shipping Label

### Label on Packaging Box

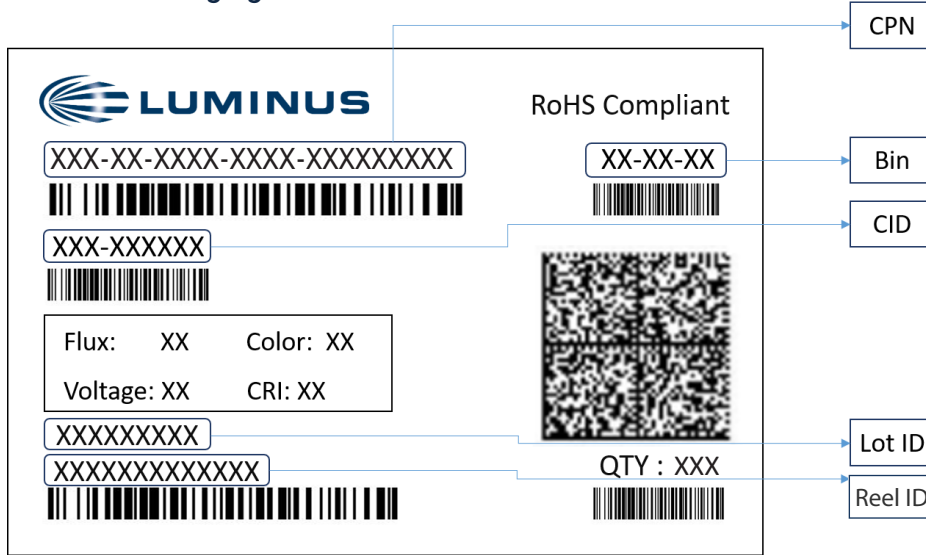

#### Label Fields:

- CPN: Luminus ordering part number
- CID: Customer's part number
- QTY: Quantity of parts per reel
- Flux: Bin as defined on page 3
- Voltage: Bin as defined on page 3
- Color: Bin as defined on page 4
- CRI: NA
- Lot ID & Reel ID: For Luminus internal use

### Label on Reel

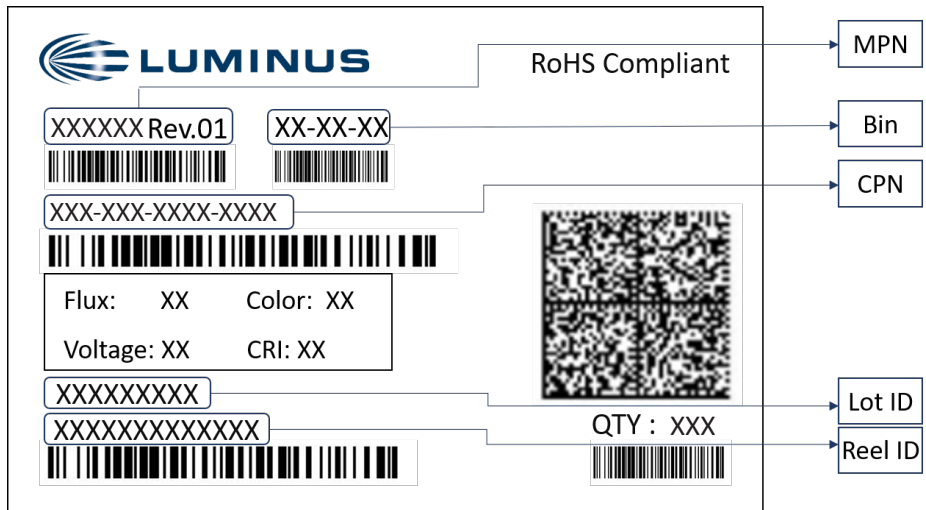

#### Label Fields:

- CPN: Luminus ordering part number
- MPN: For Luminus internal use
- QTY: Quantity of parts per reel
- Flux: Bin as defined on page 3
- Voltage: Bin as defined on page 3
- Color: Bin as defined on page 4
- CRI: NA
- Lot ID & Reel ID: For Luminus internal use



## Packaging

### Packaged Reel

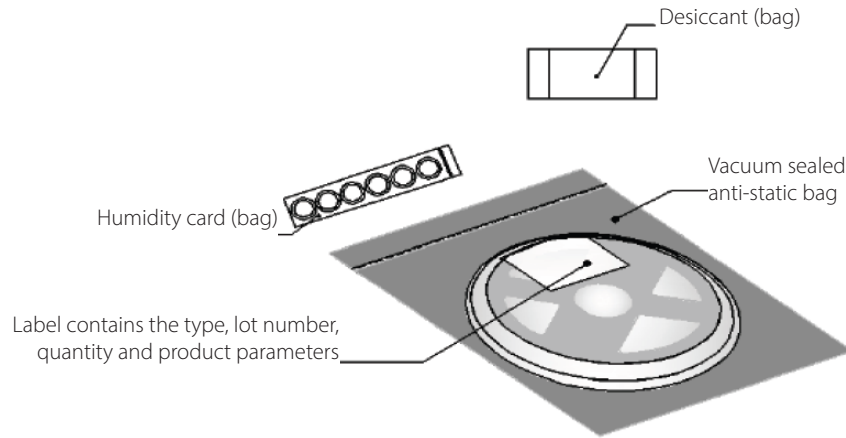

### Packaging boxes

**Box Size 1** - 5 reels per box  
Size: 22.5 x 24.5 x 6.5 cm

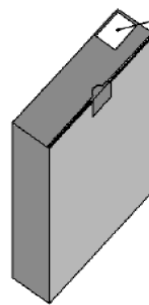
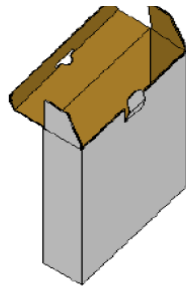

Label contains the type, lot number, quantity and product parameters

\*Capacity 5 reels per box

**Box Size 2** - 10 reels per box  
Size: 22.5 x 24.5 x 13 cm

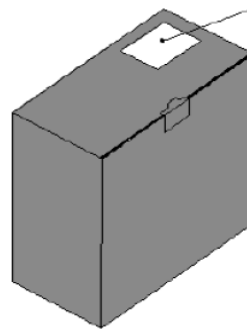
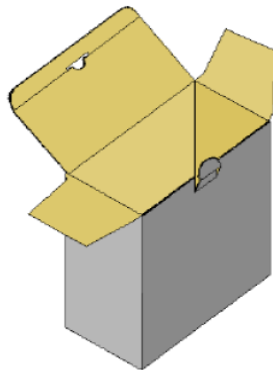

Label contains the type, lot number, quantity and product parameters

\*Capacity 10 reels per box

### Packing Configuration:

- 1,000 units per reel
- Each reel is enclosed in anti-static bag
- Shipping label is placed on top of each reel
- Multiple labels are attached to the box (one label per reel inside the box)



## Notes

### Static Electricity

1. The products are sensitive to static electricity, and care should be taken when handling them.
2. Static electricity or surge voltage will damage the LEDs. It is recommended to wear anti-electrostatic gloves or wristband when handling the LEDs.
3. All devices, equipment and machinery must be properly grounded. It is recommended that measures be taken against surge voltage to the equipment that mounts the LEDs.

Reference: [APN-002815](#) Electrical Stress Damage to LEDs and How to Prevent It

### Storage

1. Before opening the package

The LEDs should be kept at a temperature lower than 40°C and relative humidity lower than 90%. The LEDs should be used within a year. When storing the LEDs, moisture proof package with absorbent material (silica gel) is recommended.

2. After opening the package

The LEDs should be kept at a temperature lower than 30°C and relative humidity lower than 60%. The LEDs should be soldered within 168 hours (7 days) after opening the moisture proof package.

If unused LEDs remain, they should be stored in moisture proof packages, such as sealed containers with moisture absorbent material (silica gel). It is also recommended to return the unused LEDs to the original moisture proof package and to seal it again.

If the moisture absorbent material (silica gel) vaporizes or passes the expiration date, baking treatment should be performed by using the following conditions : 60°C for 20 hours.

The LED's electrode and lead frame comprise a silver plated copper alloy. The silver surface may be affected by environments. Please avoid conditions which may cause the LEDs to corrode or discolor. The corrosion or discoloration might lower solderability or affect optical characteristics.

Please avoid rapid transition in ambient temperature, especially in high humidity environments where condensation can occur.