

SST-70X-WS Gen 2

High Power White LEDs

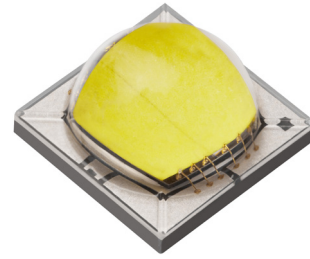

Features

- 6 V or 12 V configurable on PCB layout, excellent color and brightness uniformity across the emitting surface of a single multi-junction monolithic chip.
- High brightness cool white LEDs with maximum output in excess of 3500 lm @ 5.25 A (6 V), 85°C.
- Vertical chip with high lumen density and small emitting angle, ideal for efficient optical beam shaping to achieve high intensity, narrow beam angle and long beam distance.
- Phosphor-on-chip with superior color uniformity over radiation angles, delivering homogeneous color in beam spots.
- Maximum Drive Current: 5.25 A (6 V), 2.625 A (12 V)
- Color Temperature: 6500K
- Color Rendering Index: Typ. 70
- Low thermal resistance: 0.6° C/W
- ANSI-compatible chromaticity bins
- Electrically isolated thermal path
- 8 kV HBM ESD rating per ANSI/ESDA/JEDEC JS-001



Applications

- Portable Lights
- Automotive Auxiliary Lights
- Battery or Solar Powered Lights
- LED Work Lights
- Outdoor and Roadway Lighting
- High Bay Industrial Lighting

Table of Contents

Ordering Information.....	2
Binning Structure.....	3
Absolute Maximum Ratings.....	6
Characteristics.....	6
Soldering Profile.....	10
Mechanical Dimensions.....	11
Tape and Reel Outline.....	12
Shipping Label.....	13
Packaging.....	14
Notes.....	15



Ordering Information

Ordering Part Numbers¹

CRI	CCT	Luminous Flux		Chromaticity Bin Kit ³	Ordering Part Numbers
		Minimum Flux Bin ¹	Minimum Flux ²		
Typ. 70 Min. 65	6500K	H2	1290 lm	651	SST-70X-WS65-H2-H2651
				652	SST-70X-WS65-H2-H2652
				703	SST-70X-WS65-H2-H2703

Part Number Nomenclature

SST	70X	W<xy>	H<#>	<ffccc>
Product Family	Chip Area	Color	Package Configuration	Bin Kit
S: Surface Mount S: Dome Lensed T: Single Emitter	70X: 7.0 mm ²	W: White <x> CRI Category Code S: CRI>65 <yy> Color Temperature 65: 6500K	H: Package Code <#> Chip Generation 2: Gen 2	<ff> Minimum Flux Bin, see 'Luminous Flux Binning' table for details <ccc> Chromaticity Bin Kit, see 'Chromaticity Bin Kit Codes' table for details

Notes:

- The Ordering Part Number specifies the Minimum Flux Bin in shipment; higher flux bins may be shipped without advance notice. Please refer to 'Luminous Flux Binning' table for details of all flux bins.
- Product test condition: $I_f = 750 \text{ mA}$ (12 V), 1500 mA (6 V), $T_j = 85^\circ\text{C}$.
- Shipments always adhere to the color bins specified in each Chromaticity Bin Kit. See 'Chromaticity Bin Kit Codes' table for the color bins included in each Bin Kit.



Binning Structure

Luminous Flux Binning^{1,2}

Flux Bin Code	Binning @ 750 mA (12 V), 1500 mA (6 V)		Correlated Minimum Flux (lm) @ T _j =85°C ²					
	T _j =85°C ¹		T _j =25°C ¹	350 mA (12 V)	1000 mA (12 V)	1500mA (12 V)	2000 mA (12 V)	2625 mA (12 V)
	Minimum Flux (lm)	Maximum Flux (lm)	Minimum Flux (lm)	700 mA (6 V)	2000 mA (6 V)	3000 mA (6 V)	4000 mA (6 V)	5250 mA (6 V)
H2	1290	1375	1445	658	1651	2296	2864	3483
H3	1375	1460	1540	701	1760	2448	3053	3713
H4	1460	1565	1635	745	1869	2599	3241	3942
H5	1565	1670	1753	798	2003	2786	3474	4226

Forward Voltage Binning

Voltage Bin Code	Minimum Voltage (V)	Maximum Voltage (V)
V1	12 V ³	
	10.50	12.50
	6 V ³	
	5.25	6.25

Notes:

- LEDs are measured at 25°C ambient temperature with 750 mA (12 V) and 1500 mA (6 V), 20ms single pulse. The measured values are correlated to values at 85°C junction temperature (T_j). Luminus maintains a ±6% tolerance on flux measurement.
- Flux values at other junction temperature (T_j) and/or forward current conditions are calculated and for reference only.
- Binning condition: @ 750 mA (12 V), @1500 mA (6 V).



Binning Structure

Chromaticity Binning Coordinates

CCT	Bin Code	CIE _x	CIE _y	Bin Code	CIE _x	CIE _y	Bin Code	CIE _x	CIE _y	Bin Code	CIE _x	CIE _y
6500K	BA	0.3048	0.3207	BB	0.3028	0.3304	BC	0.3115	0.3391	BD	0.3130	0.3290
		0.3130	0.3290		0.3115	0.3391		0.3205	0.3481		0.3213	0.3373
		0.3144	0.3186		0.3130	0.3290		0.3213	0.3373		0.3221	0.3261
		0.3068	0.3113		0.3048	0.3207		0.3130	0.3290		0.3144	0.3186
	BH	0.3068	0.3113	BE	0.3005	0.3415	BF	0.3099	0.3509	BG	0.3144	0.3186
		0.3144	0.3186		0.3099	0.3509		0.3196	0.3602		0.3221	0.3261
		0.3161	0.3059		0.3115	0.3391		0.3205	0.3481		0.3231	0.3120
		0.3093	0.2993		0.3028	0.3304		0.3115	0.3391		0.3161	0.3059
7500K	AA	0.2950	0.297	AB	0.2920	0.3060	AC	0.2984	0.3133	AD	0.2984	0.3133
		0.2920	0.306		0.2895	0.3135		0.2962	0.3220		0.3048	0.3207
		0.2984	0.3133		0.2962	0.3220		0.3028	0.3304		0.3068	0.3113
		0.3009	0.3042		0.2984	0.3133		0.3048	0.3207		0.3009	0.3042
	AH	0.2980	0.2880	AE	0.2895	0.3135	AF	0.2962	0.3220	AG	0.3037	0.2937
		0.2950	0.2970		0.2870	0.3210		0.2937	0.3312		0.3009	0.3042
		0.3009	0.3042		0.2937	0.3312		0.3005	0.3415		0.3068	0.3113
		0.3037	0.2937		0.2962	0.3220		0.3028	0.3304		0.3093	0.2993



Binning Structure

Chromaticity Binning Diagram¹

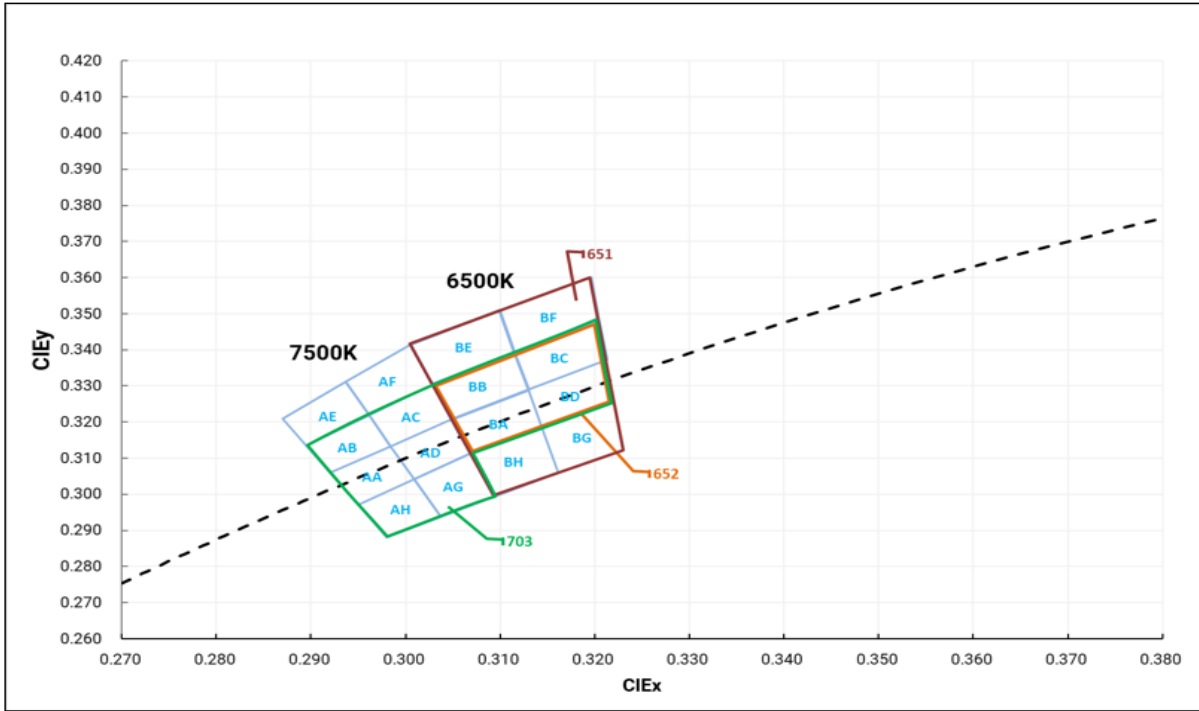

Chromaticity Bin Kit Codes

CCT	Bin Kit	Chromaticity Bins
6500K	651	BA, BB, BC, BD, BE, BF, BG, BH
	652	BA, BB, BC, BD
6500K - 7500K	703	AA, AB, AC, AD, AG, AH, BA, BB, BC, BD

Note:

- LED chromaticity is measured and binned at 25°C ambient temperature with 750 mA (12 V) and 1500 mA (6 V), 20 ms single pulse.
- Luminus maintains a tolerance of ± 0.005 on Chromaticity (CIE_x, CIE_y) measurement.



Absolute Maximum Ratings

Parameter	Symbol	Value		Unit	
		12V	6V		
DC Forward Current	Minimum	$I_{f\ min}$	0.1	0.2	A
	Maximum	$I_{f\ max}$	2.625	5.25	
Surge Current (t<10 ms, Duty Cycle < 10%)		I_s	4	8	A
Reverse Voltage ($I_f = 10\ mA$)		V_r	20	10	V
Power Dissipation		P_D	38		W
Junction Temperature		$T_{j\ max}$	150		°C
Operating Temperature Range		T_{opr}	-40 to 100		°C
Storage Temperature Range		T_{stg}	-40 to 100		°C
ESD withstand Voltage HBM Per ANSI/ESDA/JEDEC JS-001		V_{HBM}	8		kV
ESD withstand Voltage CDM Per ANSI/ESDA/JEDEC JS-002		V_{CDM}	1		kV

Characteristics

Parameter	Symbol	Value		Unit	
		12V @ 750 mA	6V @ 1500 mA		
Forward Voltage ($T_j = 85^\circ\text{C}$)	Minimum	$V_{f\ min}$	10.5	5.25	V
	Typical	$V_{f\ typ}$	11.5	5.75	
	Maximum	$V_{f\ max}$	12.5	6.25	
Temperature Coefficient of Voltage		$\partial V_f / \partial T$	-5.14	-2.57	mV/°C
Color Rendering Index ¹ ($T_j = 85^\circ\text{C}$)	Minimum	CRI_{min}	65		
	Typical	CRI_{typ}	70		
Viewing Angle (FWHM)		$2\theta_{1/2}$	135°		
Thermal Resistance (Electrical) Junction/Solder Point		$R_{thjs-EL}$	0.6		°C/W

Note:

1. Luminus maintains a tolerance of ± 2 on Color Rendering Index (CRI) measurement.



Relative Luminous Flux- 12 V

Forward Current: $\phi_v/\phi_v(0.75\text{ A}, 12\text{ V}), T_j = 85^\circ\text{C}$

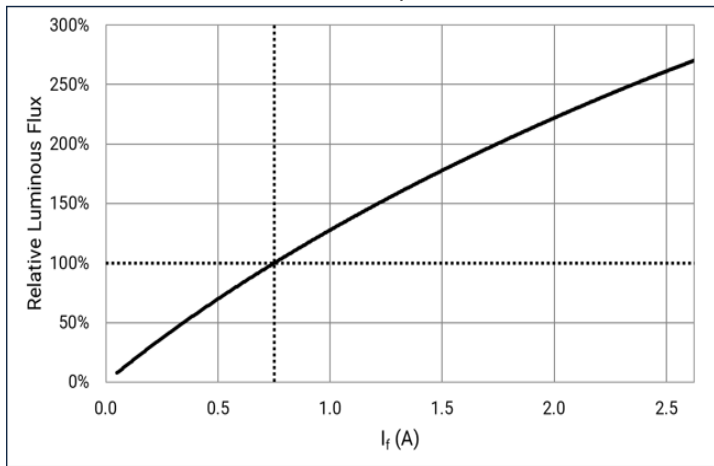

Temperature (T_j): $\phi_v/\phi_v(85^\circ\text{C}), I_f = 0.75\text{ A} (12\text{ V})$

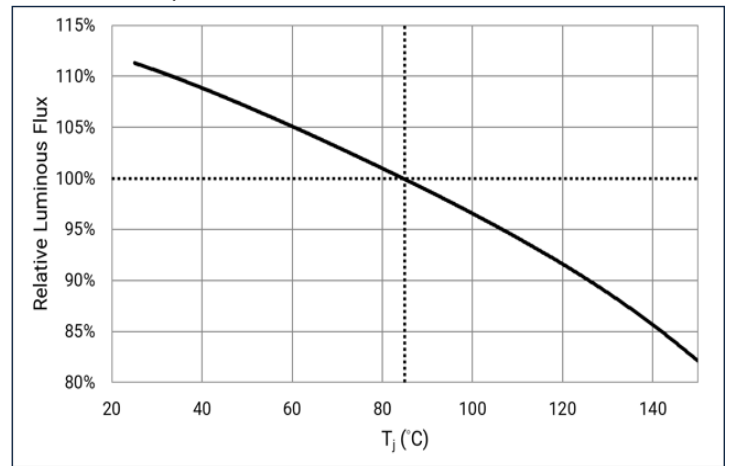

Forward Voltage - 12 V

Forward Current: $\Delta V_f = V_f(I_f) - V_f(0.75\text{ A}, 12\text{ V}), T_j = 85^\circ\text{C}$

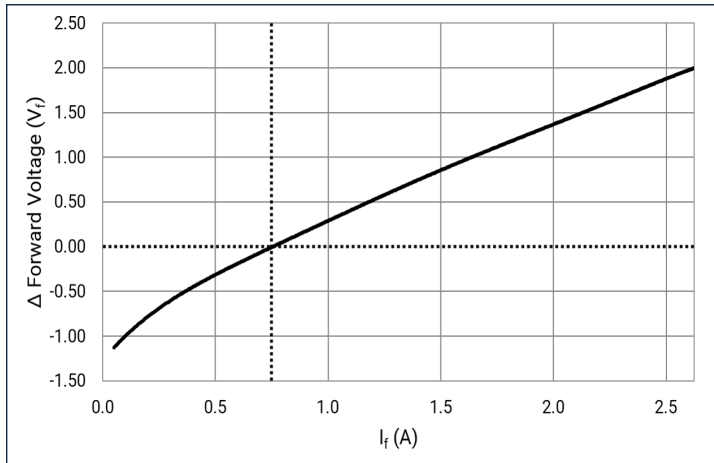

Temperature (T_j): $\Delta V_f = V_f(T_j) - V_f(85^\circ\text{C}), I_f = 0.75\text{ A} (12\text{ V})$

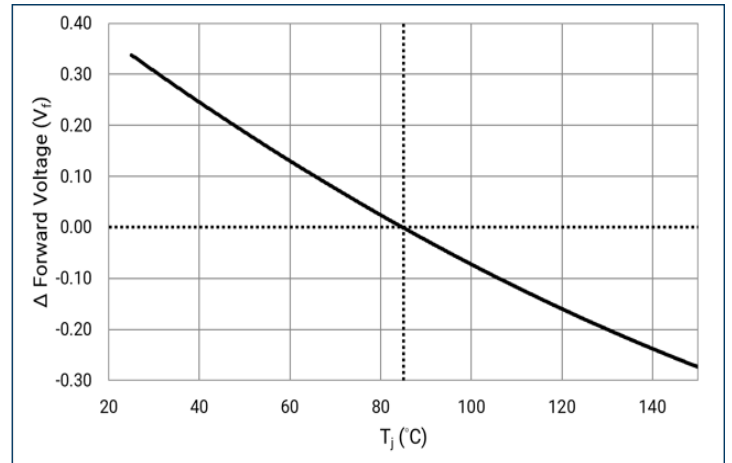

Relative Chromaticity - 12 V

Forward Current: $\Delta \text{CIEx,y} = \text{CIEx,y}(I_f) - \text{CIEx,y}(0.75\text{ A}, 12\text{ V}), T_j = 85^\circ\text{C}$

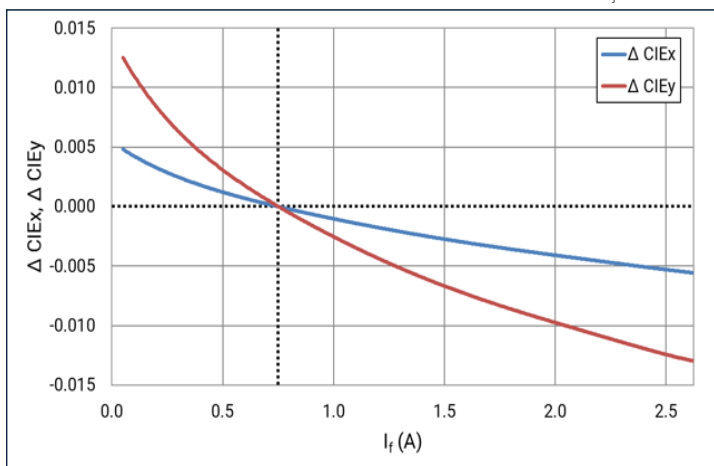

Temperature (T_j): $\Delta \text{CIEx,y} = \text{CIEx,y}(T_j) - \text{CIEx,y}(25^\circ\text{C}), I_f = 0.75\text{ A} (12\text{ V})$

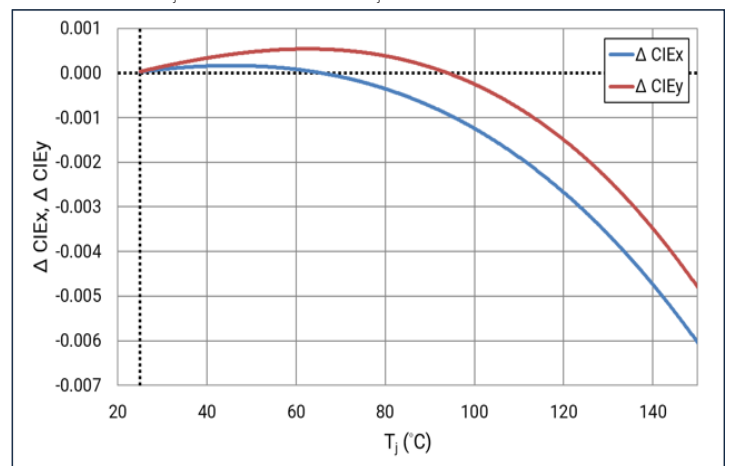



Relative Luminous Flux - 6 V

Forward Current: $\phi_v/\phi_v(1.5\text{ A}, 6\text{ V}), T_j = 85^\circ\text{C}$

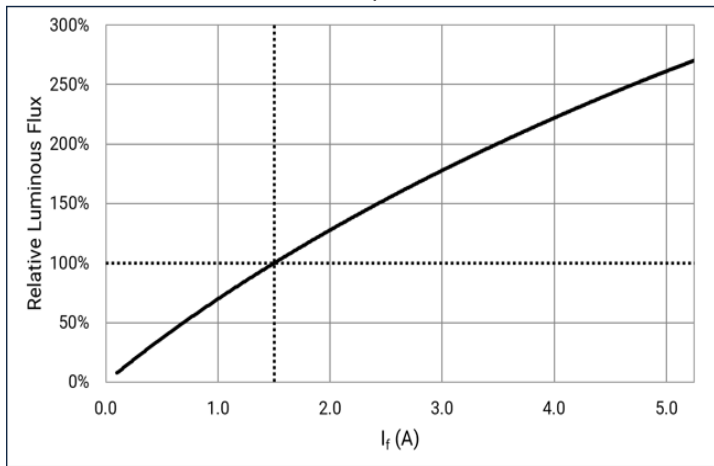

Temperature (T_j): $\phi_v/\phi_v(85^\circ\text{C}), I_f = 1.5\text{ A} (6\text{ V})$

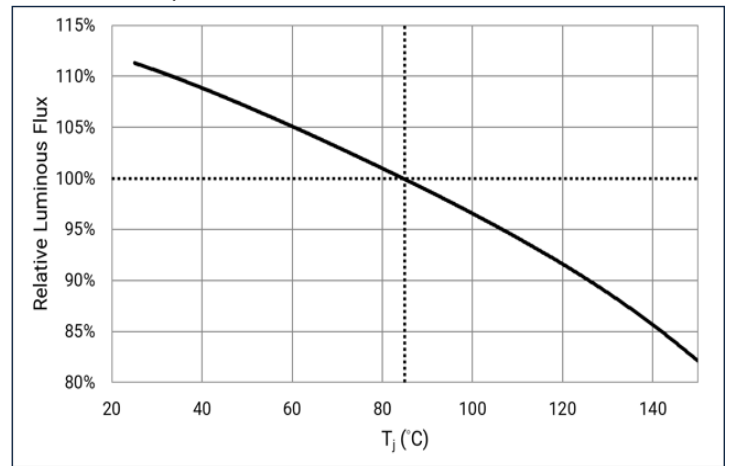

Forward Voltage - 6 V

Forward Current: $\Delta V_f = V_f(I_f) - V_f(1.5\text{ A}, 6\text{ V}), T_j = 85^\circ\text{C}$

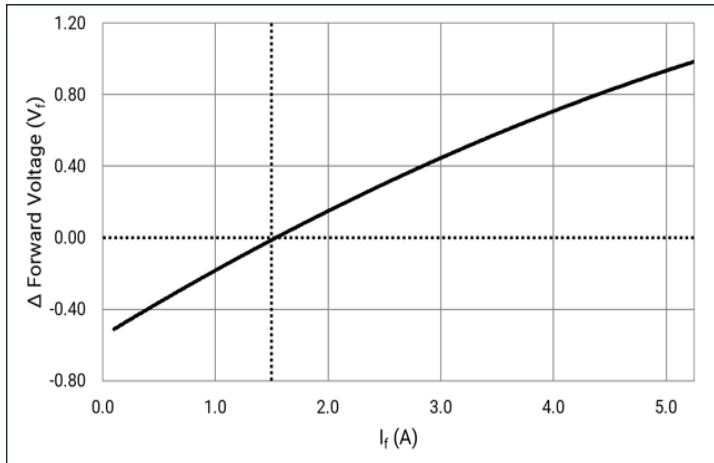

Temperature (T_j): $\Delta V_f = V_f(T_j) - V_f(85^\circ\text{C}), I_f = 1.5\text{ A} (6\text{ V})$

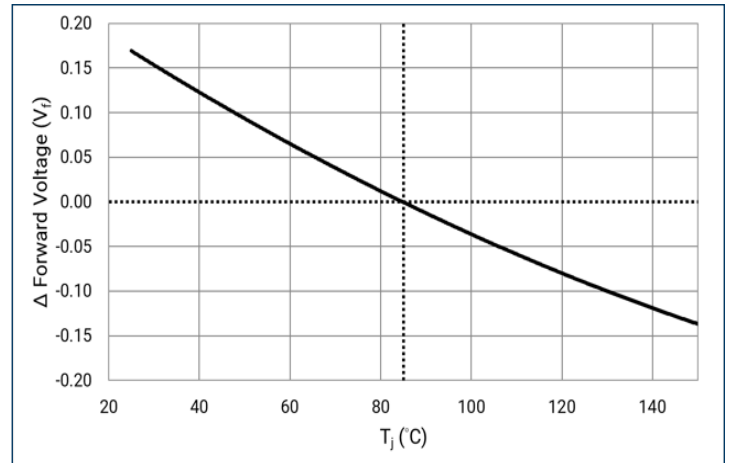

Relative Chromaticity - 6 V

Forward Current: $\Delta \text{CIEx,y} = \text{CIEx,y}(I_f) - \text{CIEx,y}(1.5\text{ A}, 6\text{ V}), T_j = 85^\circ\text{C}$

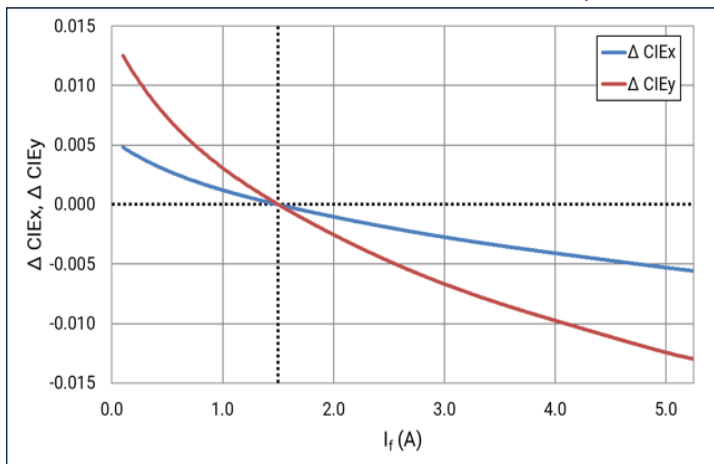

Temperature (T_j): $\Delta \text{CIEx,y} = \text{CIEx,y}(T_j) - \text{CIEx,y}(25^\circ\text{C}), I_f = 1.5\text{ A} (6\text{ V})$

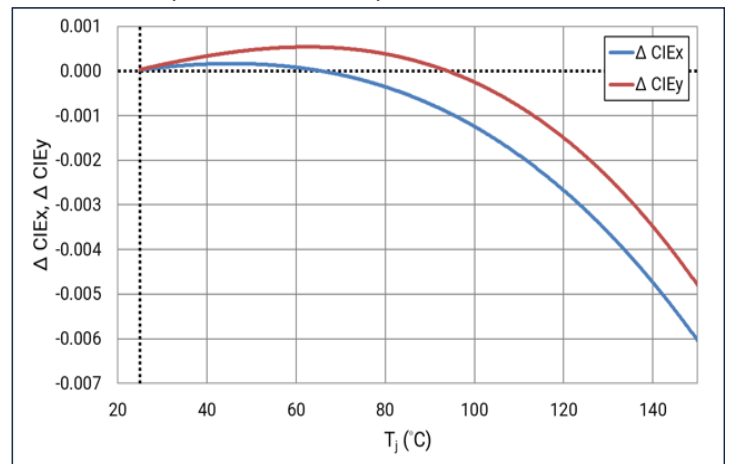



Angular Distribution

$I_f = 0.75 \text{ A (12 V)}$; $T_j = 25^\circ\text{C}$

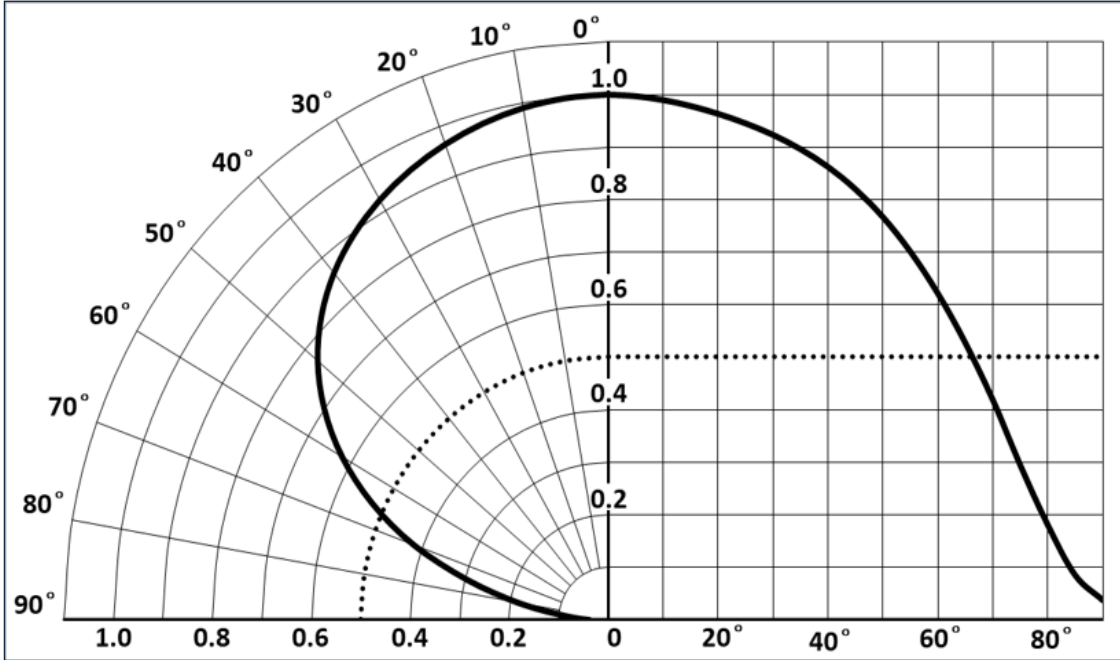

Relative Spectral Power Distribution

$I_f = 0.75 \text{ A (12 V)}$; $T_j = 85^\circ\text{C}$

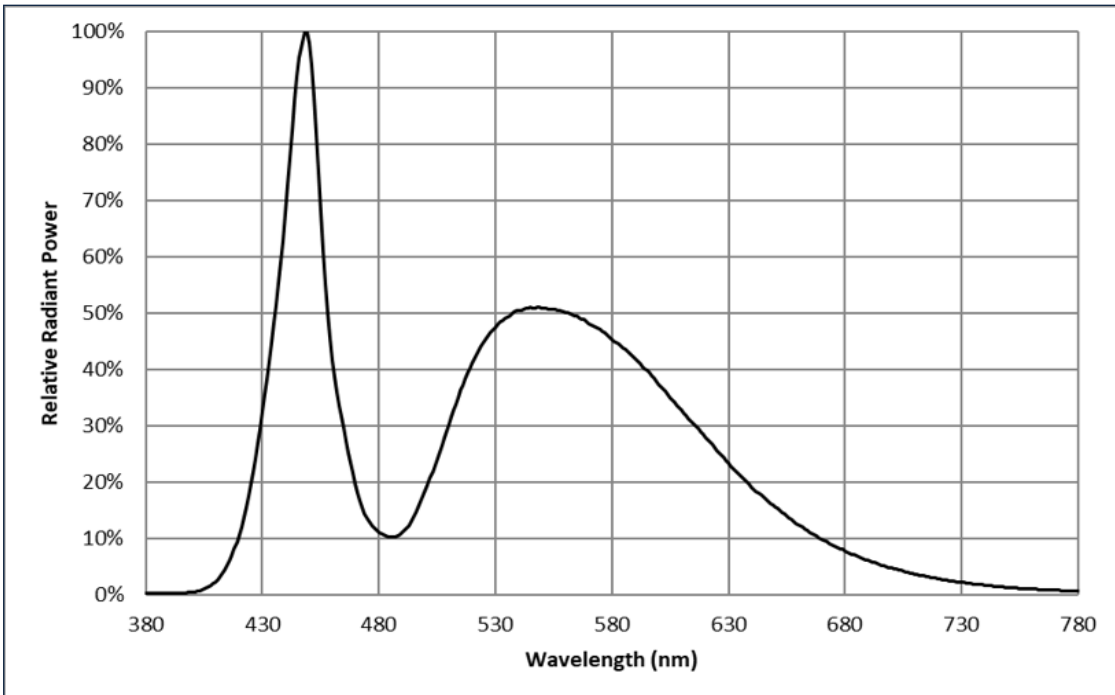



Soldering Profile

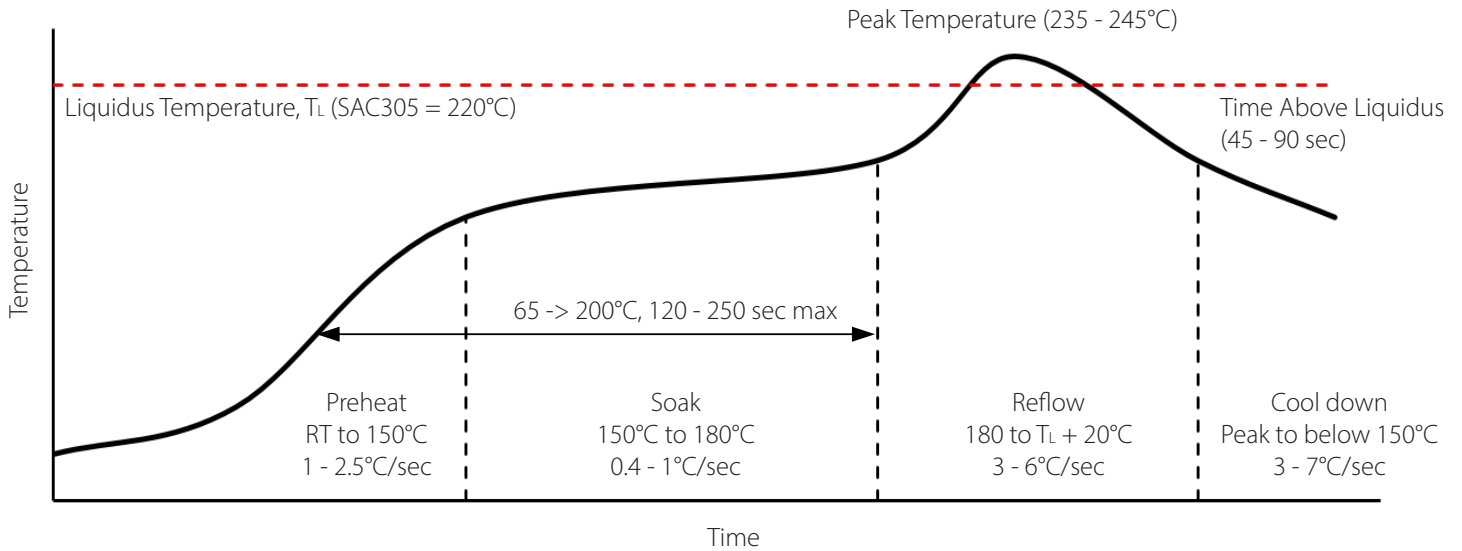

SMT Rework Guideline	Manual Hotplate Reflow	Hot Air Gun Reflow
Heating Time		< 60 sec
Hotplate Temperature	< 245°C	< 150°C

Note:

- Product complies to Moisture Sensitivity Level 3 (MSL 3).
- The numbers in the table are specific to SAC305. Luminus recommends using an SAC305 solder paste with a no-clean flux for RoHS compliant products.
- During the pick and place process, axial forces on the dome (or window) should not exceed 0.5 Newtons (N).
- Use of a multi-zone IR reflow oven with a nitrogen blanket is recommended.
- Time-temperature profile of the reflow process showing the four functional profile zones are defined in IPC-7801. Temperature is referenced to the center of the PCB.
- Luminus recommends to use the solder paste data sheet information as a starting point in time-temperature process development.
- These are general guidelines. Consult the solder paste manufacturer's datasheet for guidelines specific to the alloy and flux combination used in your application.
For more information, please refer to:
<https://luminusdevices.zendesk.com/hc/en-us/articles/360060306692-How-do-I-Reflow-Solder-Luminus-SMD-Components->
- For any technical questions about soldering process, please contact Luminus at techsupport@luminus.com.



Mechanical Dimensions¹

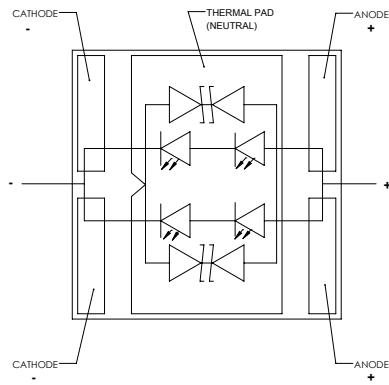
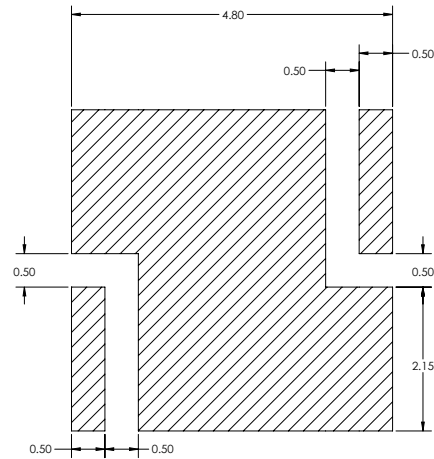
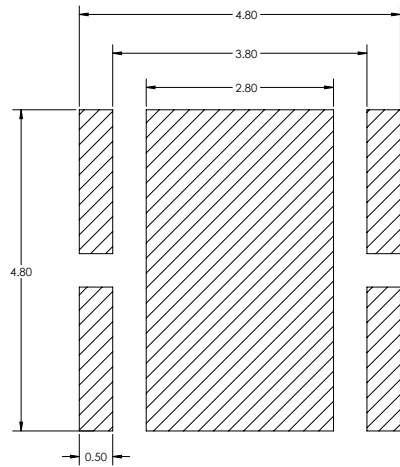
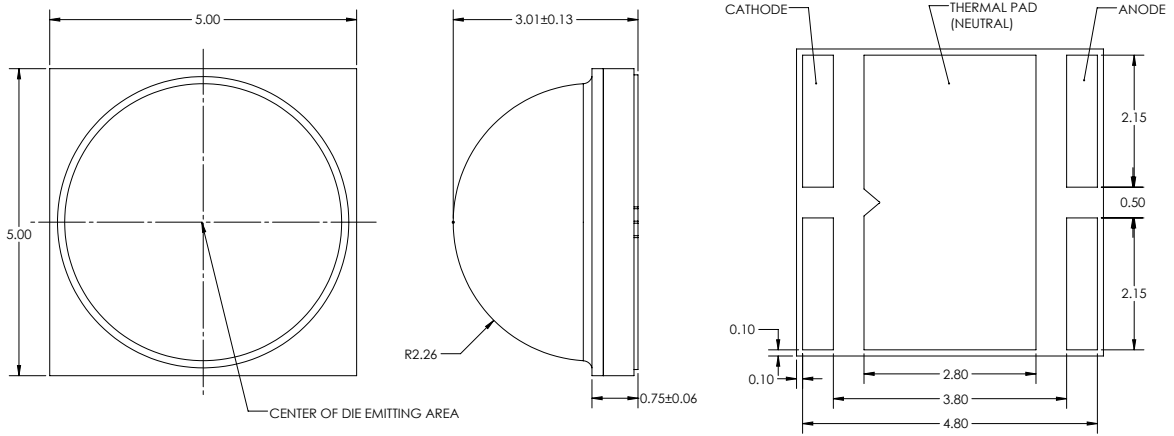

**RECOMMENDED PCB SOLDER PAD
 6V CONFIGURATION**

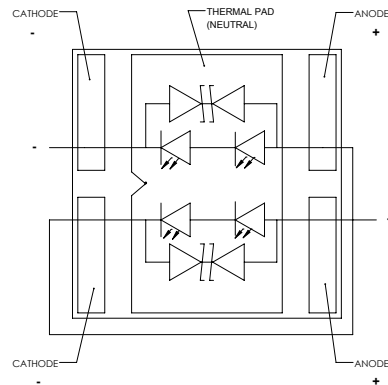

**RECOMMENDED PCB SOLDER PAD
 12V CONFIGURATION**

Note:

1. All dimensions are in millimeter ± 0.13 mm.



Tape and Reel Outline

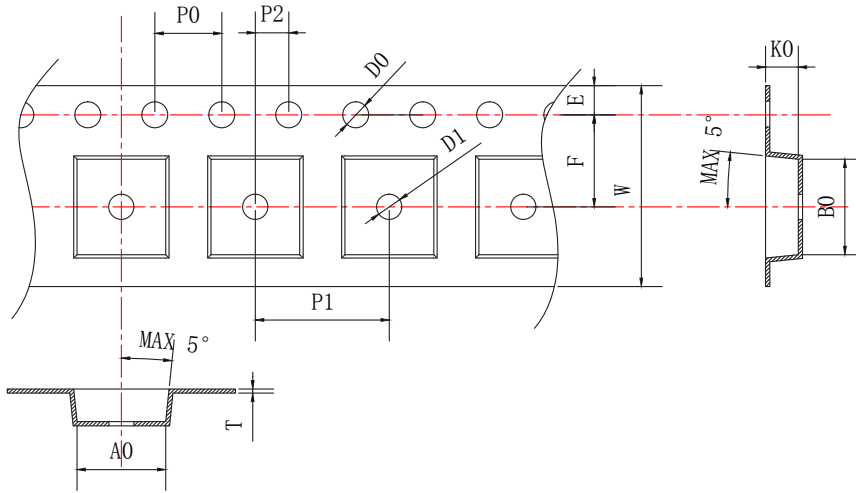

Parameter	Dimension (mm)
A0	5.15±0.1
B0	5.15±0.1
D0	1.5+0.1 1.5-0.0
D1	1.7±0.1
E	1.75±0.1
F	5.5±0.1
K0	3.0±0.1
P0	4.0±0.1
P1	8.0±0.1
P2	2.0±0.05
T	0.3±0.05
W	12±0.03

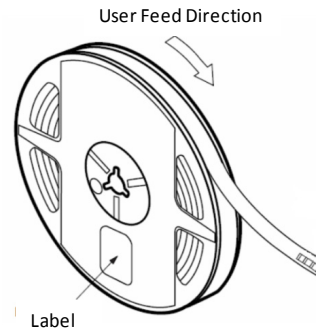
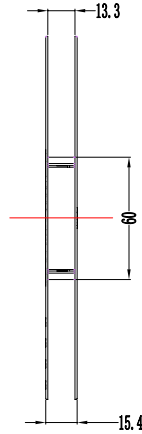
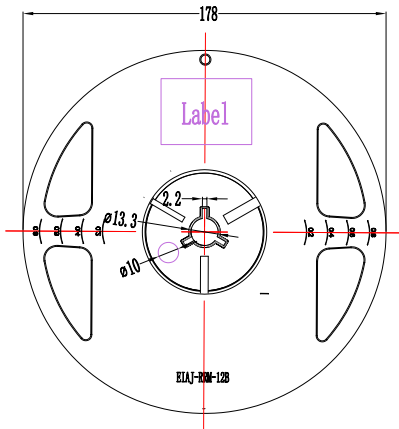

Note:

1. Each Reel contains 500 units of LEDs.
2. Black ant-static tape material (Denka ECMB/ECAP3).
3. The accumulated tolerance for ten chain holes should be no more than 0.2 mm.
4. The tortuosity of 250 mm tape should be no more than 1 mm.
5. Leave 160 mm of type empty for lead in (20 empty pockets).
6. Leave 480 mm of type empty for trailer (60 empty pockets).
7. All dimensions must comply to EIA-481-D.
8. Final tape and reel packaging must meet the requirements of JEDEC -STD-033, LEVEL 2A.



Shipping Label

Label on Packaging Box

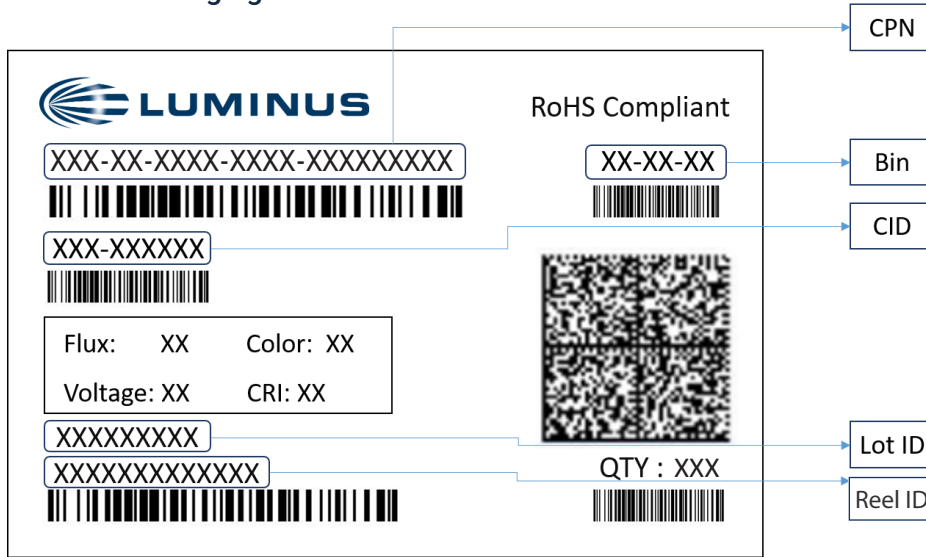

Label Fields:

- CPN**: Luminus ordering part number
- CID**: Customer's part number
- QTY**: Quantity of parts per reel
- Flux**: Bin as defined on page 3
- Voltage**: NA
- Color**: Bin as defined on page 4
- CRI**: NA
- Lot ID & Reel ID**: For Luminus internal use

Label on Reel

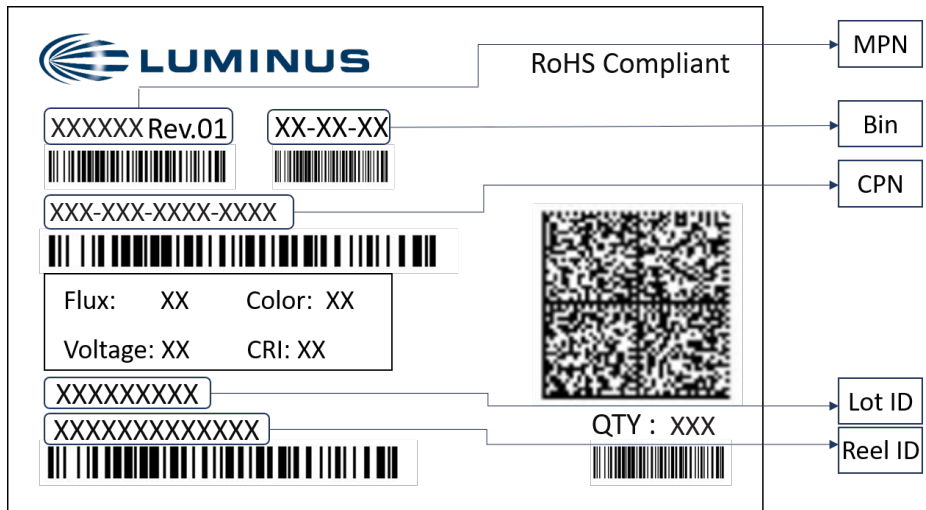

Label Fields:

- CPN**: Luminus ordering part number
- MPN**: For Luminus internal use
- QTY**: Quantity of parts per reel
- Flux**: Bin as defined on page 3
- Voltage**: NA
- Color**: Bin as defined on page 4
- CRI**: NA
- Lot ID & Reel ID**: For Luminus internal use



Packaging

Packaged Reel

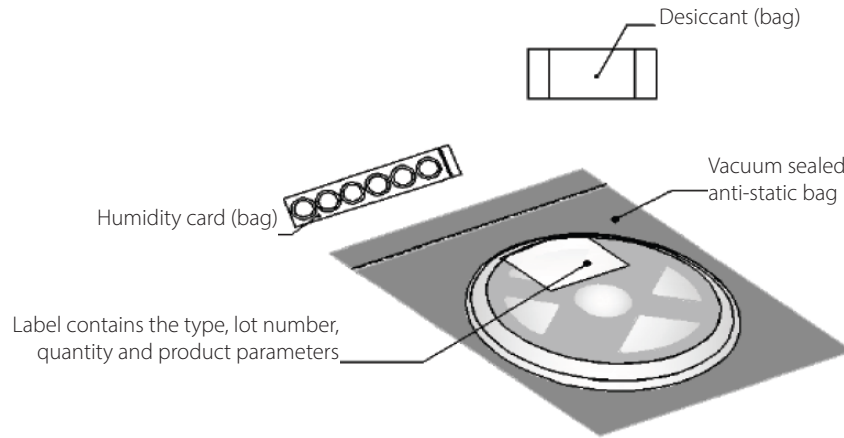

Packaging boxes

Box Size 1 - 5 reels per box
Size: 22.5 x 24.5 x 6.5 cm

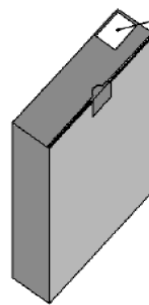
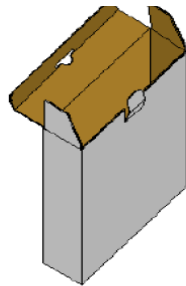

Label contains the type, lot number, quantity and product parameters

*Capacity 5 reels per box

Box Size 2 - 10 reels per box
Size: 22.5 x 24.5 x 13 cm

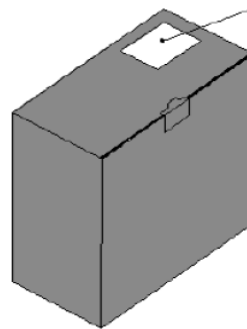
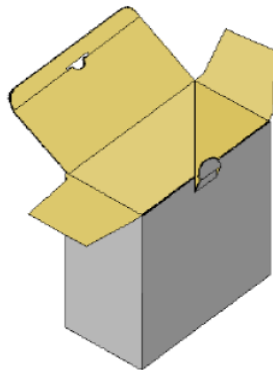

Label contains the type, lot number, quantity and product parameters

*Capacity 10 reels per box

Packing Configuration:

- 500 units per reel
- Each reel is enclosed in anti-static bag
- Shipping label is placed on top of each reel
- Multiple labels are attached to the box (one label per reel inside the box)



Notes

Static Electricity

1. The products are sensitive to static electricity, and care should be taken when handling them.
2. Static electricity or surge voltage will damage the LEDs. It is recommended to wear anti-electrostatic gloves or wristband when handling the LEDs.
3. All devices, equipment and machinery must be properly grounded. It is recommended that measures be taken against surge voltage to the equipment that mounts the LEDs.

Reference: [APN-002815](#) Electrical Stress Damage to LEDs and How to Prevent It

Storage

1. Before opening the package

The LEDs should be kept at a temperature lower than 40°C and relative humidity lower than 90%. The LEDs should be used within a year. When storing the LEDs, moisture proof package with absorbent material (silica gel) is recommended.

2. After opening the package

The LEDs should be kept at a temperature lower than 30°C and relative humidity lower than 60%. The LEDs should be soldered within 168 hours (7 days) after opening the moisture proof package.

If unused LEDs remain, they should be stored in moisture proof packages, such as sealed containers with moisture absorbent material (silica gel). It is also recommended to return the unused LEDs to the original moisture proof package and to seal it again.

If the moisture absorbent material (silica gel) vaporizes or passes the expiration date, baking treatment should be performed by using the following conditions : 60°C for 20 hours.

The LED's electrode and lead frame comprise a silver plated copper alloy. The silver surface may be affected by environments. Please avoid conditions which may cause the LEDs to corrode or discolor. The corrosion or discoloration might lower solderability or affect optical characteristics.

Please avoid rapid transition in ambient temperature, especially in high humidity environments where condensation can occur.